



Instruction Sheet

APD4+

CAT. NO. F01U173977 510-610 MHz
 CAT. NO. F01U117678 600-780 MHz
 CAT. NO. F01U117679 780-900 MHz

AMPLIFIED UHF
 ANTENNA SPLITTER

General Description

The APD4+ Amplified Antenna Splitter makes it possible to operate four UHF wireless diversity microphone receivers on four separate frequencies using only two antennas.

It also features a high degree of output isolation; a necessity in multi-frequency systems to prevent intermodulation.

The APD4+ Splitter is compatible with Electro-Voice and Telex UHF diversity wireless receivers.

SPECIFICATIONS

Frequency Range	F01U173977.....	510-610 MHz
	F01U117678.....	600-780 MHz
	F01U117679.....	780-900 MHz
3rd Order Intercept Output	greater than 18 dbm
Net Gain	greater than 2 dB
Noise Figure	less than 3 dB
Output Isolation	greater than 20 dB
Connectors, Antenna	Standard TNC receptacles
Power Requirements	90-260VAC 50/60Hz

Features

The APD4+ is equipped with TNC type connectors. Low loss coaxial cables are also supplied for splitter to receiver antenna jack connections. The APD4+ has an internal power supply. Power out jacks and cables are provided to supply up to four receivers thus eliminating excess power supply clutter.

Rack panel mounting “ears” allow the APD4+ to be mounted in a standard 19 inch equipment rack. “Knock outs” in the ears allow front connection of antenna cables.

System Configuration

Figure 2 illustrates the typical system configuration using the APD4+.

Figure 3 illustrates an arrangement where two splitters have been cascaded. By connecting one of the outputs of the first splitter to the antenna inputs of the second splitter, three additional receivers may be driven by a single pair of antennas.

SPECIAL NOTE: In any system, unused splitter outputs should be terminated with a 50 ohm “dummy load”. See the accessories listing at the end of this manual.



Front View

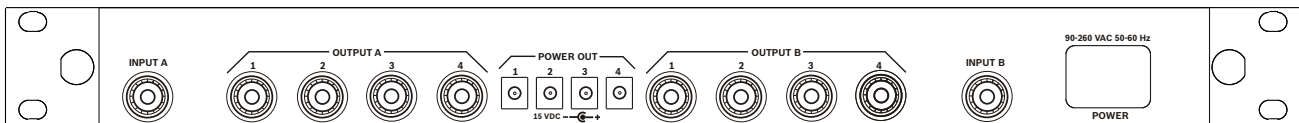

Rear View

Figure 1
Front and Rear View

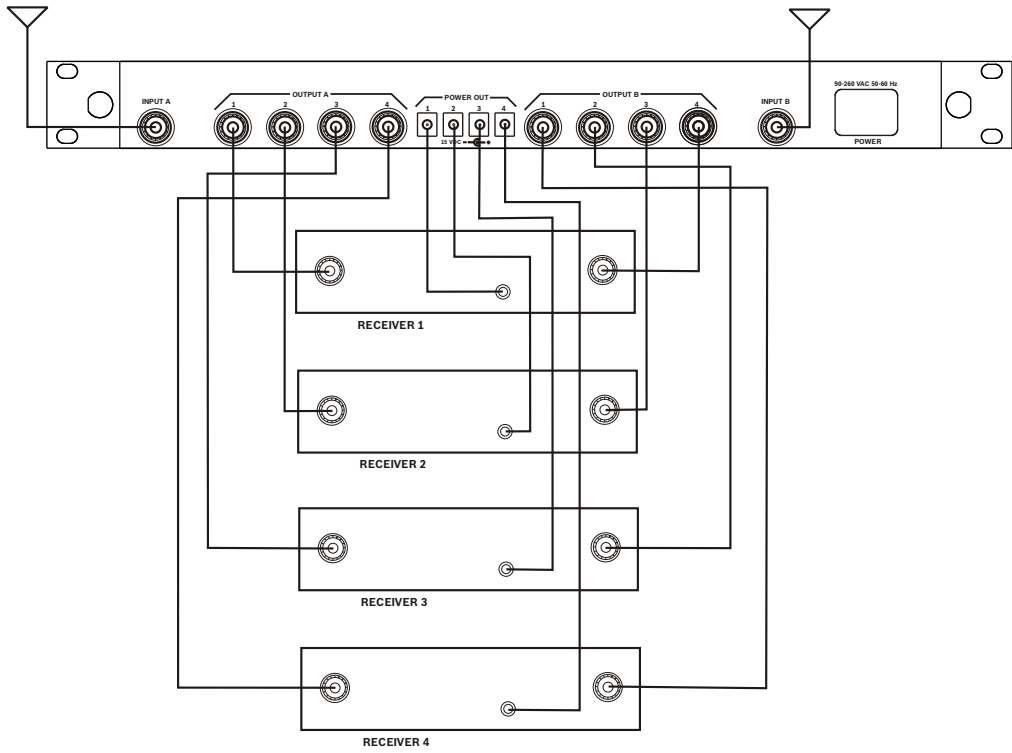

Figure 2
System Configuration

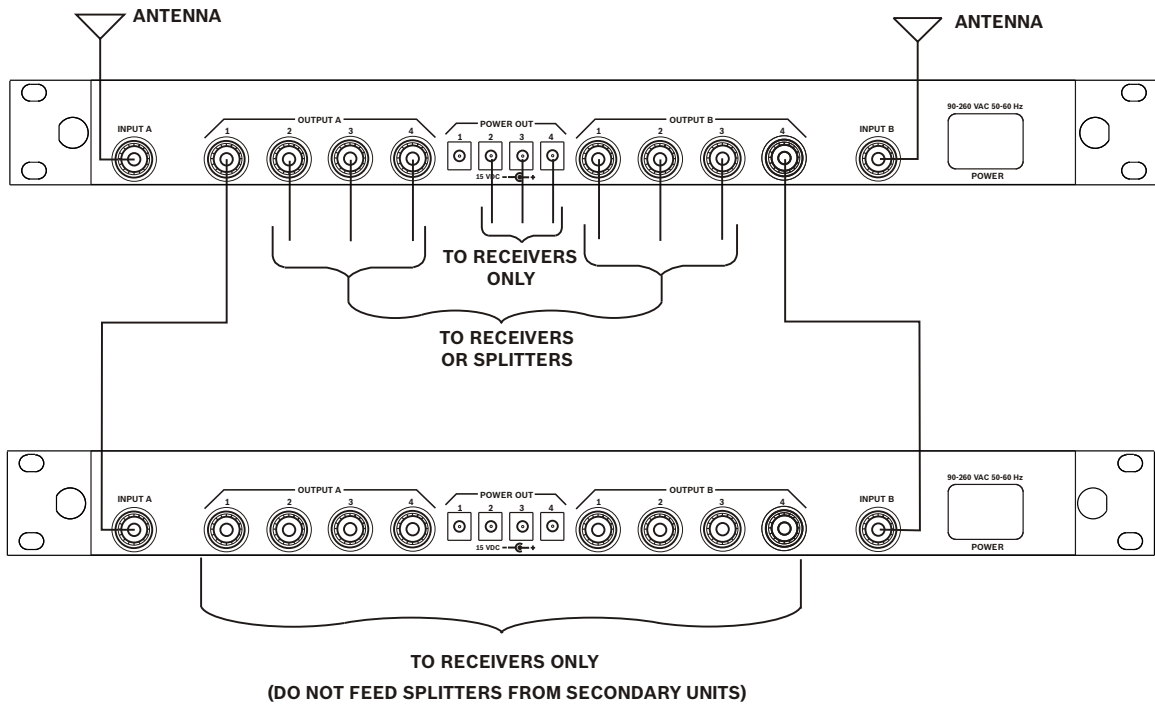

Figure 3
Cascading

Antenna Requirements

The APD4+ may be used with a variety of antennas. For best results, use a pair of LPA-500 directional log periodic antennas. See Figure 4. The LPA-500 offers the best performance and broadest bandwidth available.

Good results may be obtained with optional CLA or FA-500 1/2 wave antennas.

The 1/4-wave antennas that are supplied with EV wireless systems may provide adequate performance in some situations. **Do not** use 1/4-wave antennas for remote mounting.

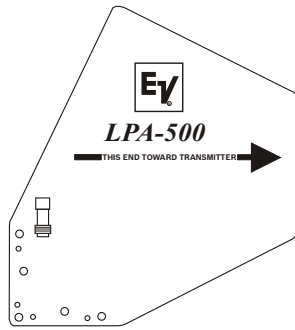

LPA-500

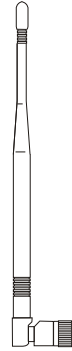

**FA-XW
1/2 Wave Flex Antenna**

**Figure 4
Antennas**

Antenna Placement

If antennas are mounted directly to the APD4+, they should be configured as shown in Figure 5.

Do not rack mount the APD4+ in this configuration. Serious loss of range and performance may occur.

Place the APD4+ with antennas in a location that is in direct view of the transmitters for best results.

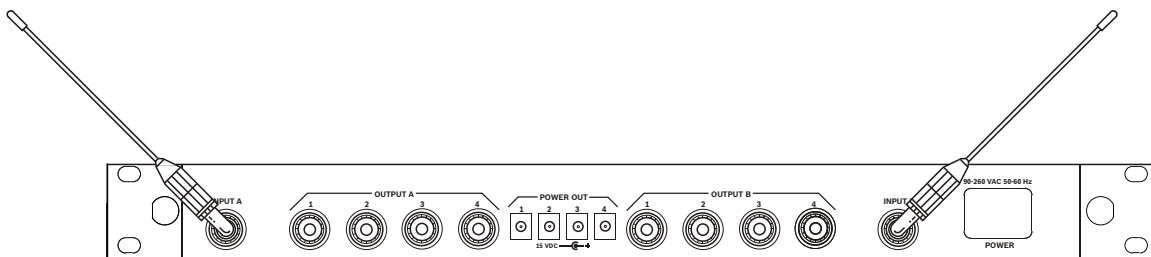

**Figure 5
1/2 Wave Antenna Mounting**

Antenna Placement for Optimum Range and Rack Mounting

For maximum range and when rack mounting, the antennas must be remotely located.

The LPA-500 comes complete with a variety of mounting hardware and 10 feet (3 meters) of low loss coaxial cable. A combination mounting bracket (Model No. AB-2) with 10 feet of coaxial cable is available for 1/2 wave antennas.

Antennas should be placed in a location with a clear “signal path” to the transmitter. This “path” should be as short and free of obstructions as possible. Obstructions, such as walls, ceilings, and metal objects, will reduce range and performance.

Rack Mounting

Insert the unit into a 19" rack enclosure and secure with screws (not supplied).

Rack Mounted Antenna Connectors

Antenna cable connections may be made to the front of the rack mounted APD4+ by installing the adaptor cables supplied. Proceed as follows:

Remove the plug “knock outs” from the front panel. See Figure 6.

Install the adaptor cables from the back side of the bracket.

Tighten the nut and lockwasher securely.

Attach the other end of the cables to the inputs of the APD4+. Tighten securely.

Front of rack antenna connectors were designed to allow easier hook up of antenna cables. We do not recommend mounting antennas directly to the connectors since performance may be degraded.

Coax Cable

For best results, it is recommended that cable losses be kept under 4 dB. (Every 3 dB of signal loss results in a system operating distance reduction of 25%.)

See the accessories section of this manual for special low loss cable assemblies.

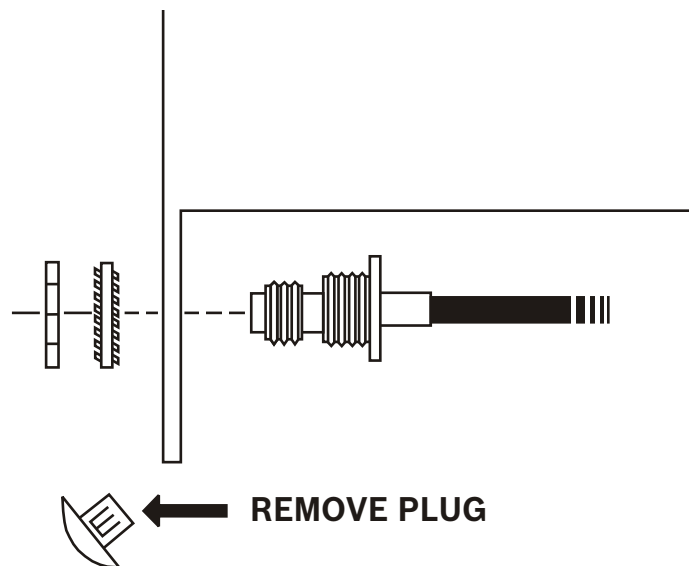

Figure 6
Antenna Connectors

12 Volt Power On "Antenna In" Jacks

To power UAA-500 in-line antenna amplifiers, 12 volt power is available on the center pin of the antenna in jacks. This power is disabled when the APD4+ leaves the factory but may be turned on by the installer.

To turn on the 12 volts, first take off the cover of the splitter by removing the screws. The Jumper is installed on one pin of the header at the factory. To turn on power, unplug the jumper and install it on both pins of the header. See Figure 7.

CAUTION: Do not attach antennas and splitters with a DC short circuit to the antenna in jacks when the power is turned on. Damage could result to the splitter or other devices.

The following antennas and accessories may be used with power on: FA-XW, CLA-X, LPA-500B, and UAA-500.

The following antennas and accessories may be used with the power off: FA-XW, CLA-X, and LPA-500.

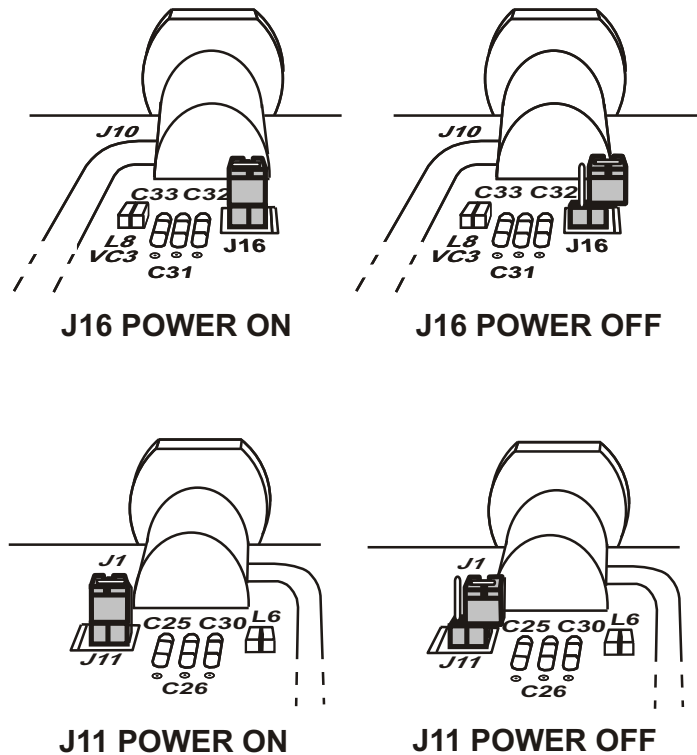

Figure 7
Moving Jumper
(Be sure to move jumper on both headers)

APD4+ Accessories and Replacement Parts

AC Power Cables

550024000	Europe
550024002	U.K.
550024013	North America
690513	Japan

TP-2 50 OHM/TNC dummy load
 (For unused outputs on the UAD-2)
Part No. 650095

APD4+ Cables

Model	Type	Part No.
CXU-2	2 Ft. Coaxial Cable	691459
PC-1	2 Ft. Power	690396
CXU-1	1 Ft. Coaxial Cable (for rack ears)	690401

Special low loss antenna cables with TNC connectors

Model	Length	Order No.
CXU-10	10 Ft. (3 meter)	690419
CXU-25	25 Ft. (7.6 meter)	71151-025
CXU-50	50 Ft. (15 meter)	71150-075
CXU-75	75 Ft. (23 meter)	71151-075
CXU-100	100 Ft. (30 meter)	71151-100

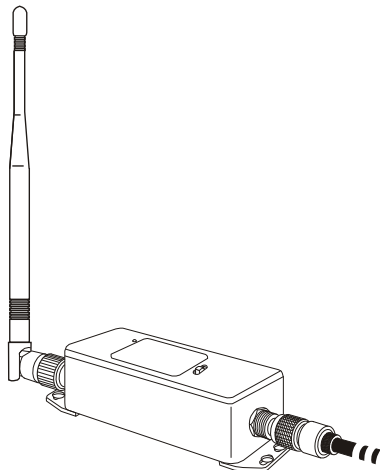

UAA-500
 Low noise antenna amplifier, 500-900 MHz
 (antenna not included)
Order No. 7186400

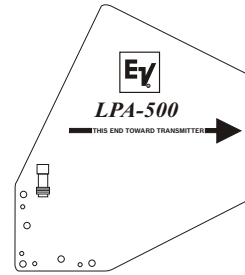

LPA-500
 450-900 MHz Log Periodic Antenna
 Includes mounting hardware and 10 feet (3 meter) coaxial cable with TNC connectors
Order No. LPA-500

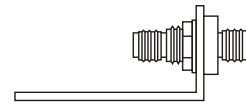

AB-2 Combination
 Antenna Bracket and 10 foot (3 meter) coaxial cable with TNC connectors. Use with FA-XW
Order No. 71138000

FA-XW Halfwave Flex Antenna

FA-RW	470-550 MHz
FA-YW	525-610 MHz
FA-GW	610-710 MHz
FA-BW	710-880 MHz

