

LEDBLADE

CRE:ON – Hybrid Pixel Drive

User manual for
firmware v.2.0

THANK YOU FOR PURCHASING LEDBLADE CREON-HYBRID PIXEL DRIVE



Please read the user manual carefully before using the CRE:ON Hybrid Pixel Drive. If you have any further questions, please contact The LEDBLADE Team.

support@ledblade.com

LEDBLADE kft
Kelenföldi út 2
H-1115 Budapest

www.ledblade.com
info@ledblade.com



Keep your CRE:ON HD trending! Don't forget to sign up for our firmware updates newsletter.

<https://subscribe.ledblade.com/creon>

Contents

General description of the equipment ...5

Description ... 5

Operation of the equipment ...6

Safety and fixing points ... 6

Basics ... 7

Power Connectors

Input and Output connectors

Network connectors

First start guide as an ArtNet node ... 8

Details ...9

Networking ... 9

Handling ... 9

ArtNet, sACN ... 10

User interface	...11
Basic GUI buttons	... 11
Main screen	... 11
Settings 	... 12
Protocols:	
Network:	
Manual:	
System:	
CRE:ON HD Technical Specifications	...14
Connecting diagram	...15

General description of the equipment

Description

The LEDBLADE CRE:ON-HD unit is a power supply and a digital led strip controller card in one case as a "Hybrid Drive". The CRE:ON HD was developed specially for the event industry.



It has IP33 outdoor rating when the front panel is facing down.

CRE:ON HD works with and can be connected to both indoor and outdoor versions of straight and curved LEDBLADE ledstripe units.

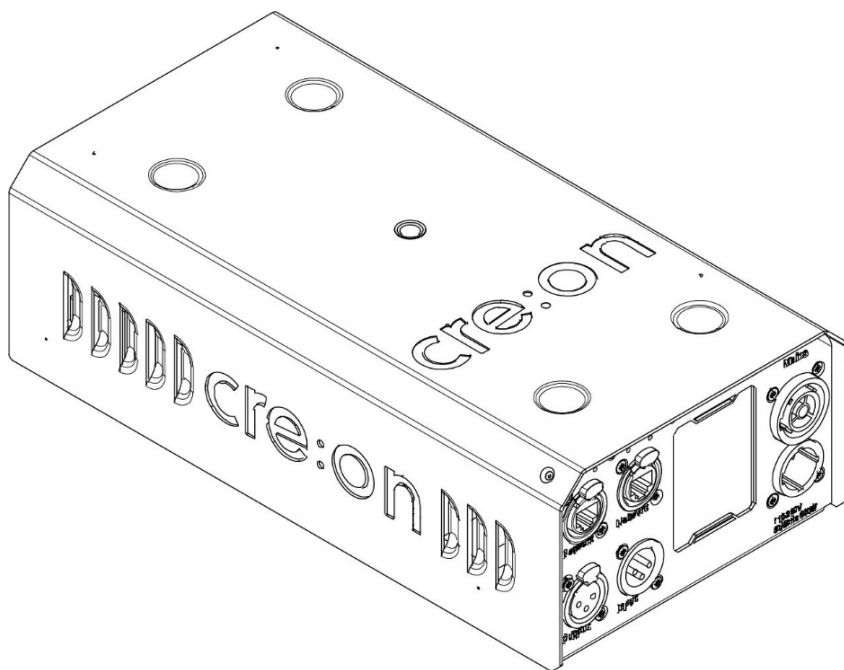

Operation of the equipment

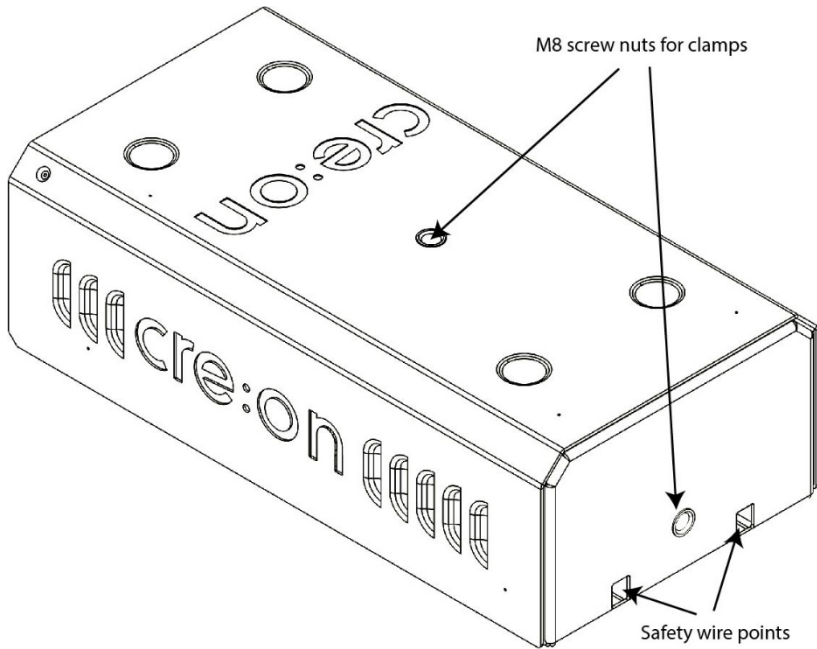

Safety and fixing points

There's one M8x15mm fixing point on the top and one on the back side of the cover for clamps. There are two (2) safety wire fixing points on the back side.



There are two (2) safety wire fixing points on the back side.

Maximum operational temperature is 60 Degrees Celsius.

Basics

Let's see the basics of the CRE:ON HD:

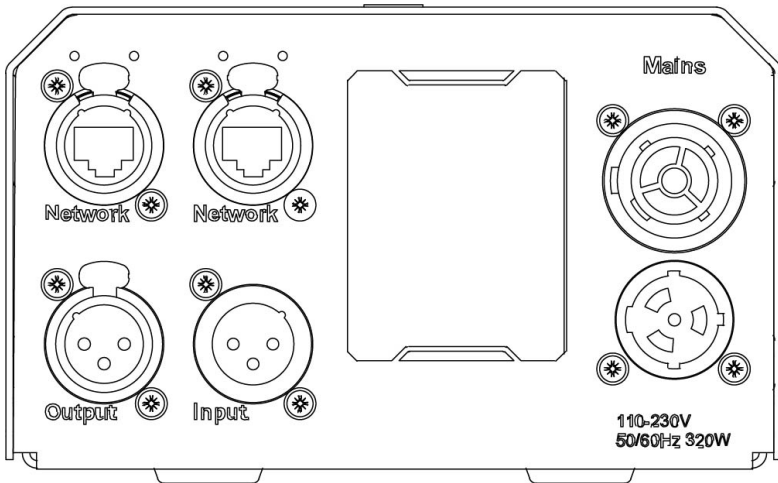

Power Connectors

The input voltage is 100 - 240V @50-60Hz, maximum power consumption: 320W. Please use at least 3x1,5mm² cable with standard Neutrik powerCON true1 series connector for power connection and for daisy chain. We suggest ten (10) CRE:ON HD units connected in daisy chain as maximum.



There's no dedicated power switch on the device, this function is served by the Neutrik connector. Make sure that the power connectors are easily accessible to turn off the unit for cases of unforeseen emergency situations! Make sure that the power source is protected against overload!

Input and Output connectors

Use the Input port when the unit is switched to 'Bypass' mode or in 'SPI mode' for DMX triggering.

The Output port is dedicated to LEDBLADE units.

The output voltage is 24VDC on the standard Neutrik NC3FD-H-BAG connectors.

Network connectors

Standard Neutrik NE8FDP-B connectors.

First start guide as an ArtNet node

- Unwrap the CRE:ON driver
- Connect a LEDBLADE unit to the output
- Connect your controller to the power source
- Connect your devices to the same network
- Set the unit IP range to 2.x.x.x or 10.x.x.x /These are the standard ArtNet ranges, take care of the IP collision/
- Set the subnet mask to 255.0.0.0
- Start the controller software like Madrix, Resolume, Arkaos, or lighting consol...
 - You will see the CREON node on the network
 - Set the subnet to 0 and univers to 0
 - Prefer the unicast instead of broadcasting so choose the correct driver
 - Repeat as many times as the number of CRE:ON units you have in the network

Details

Networking

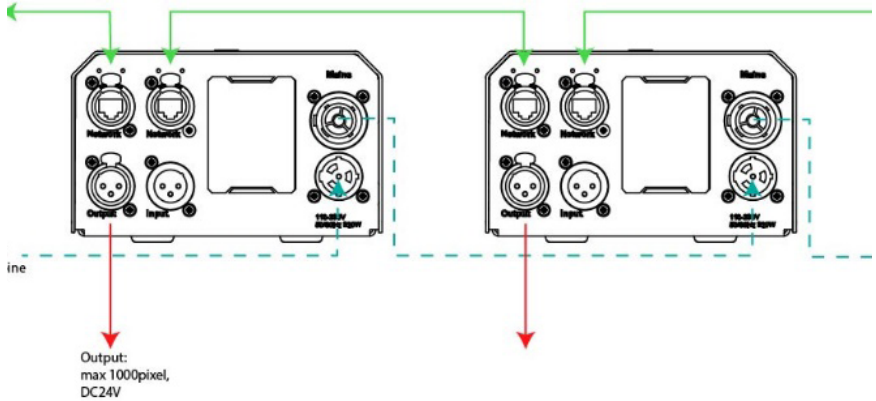

The signal communication is based on standard Ethernet communication and runs through a 100/1000 switch powered separately. Use cat5e or higher ranked cable for daisy chain and standard connectors for the best result. We suggest maximum 10 units in chain, use a standard gigabit switch to expand the networking.

! Every cases we suggest to use ArtNet Unicast / when send data directly to exact IPs/, to avoid the package lost and process lag on the network when use a lot of parameters

Handling

You can find a 2,8" resistive touch screen on the front, to manage all of the editable parameters like

- IP address
- Pixel modes
- Network paramters

- test animations
- ...

To use these controllers choose a standard ArtNet/sACN output based software (Resolume, Madrix, Arkaos, MadMapper, etc) or use LedStripStudio 2 software.

ArtNet, sACN

The device communication based on the Artistic License ArtNet 4 standards. It can receive both protocols at the same time. You don't need to turn OFF the protocols, but you can in the 'Protocols' menu. Just stream your controlling signal to the CREON. If you want to know more about ArtNet4 please visit: <https://art-net.org.uk/>



To get discoverable CREON nodes on the network, use the 255.0.0.0 subnet mask!

Control types:







- ArtNet broadcast
- ArtNet unicast
- sACN broadcast
- sACN unicast

Example:

1. *grab a CREON with some blades*
2. *turn on*
3. *plug in the networking cable*
4. *set the IP and the starting universe number at the 'Settings/Networking'*
5. *tap on the  to save the setting*
6. *Broadcast or multicast the signal to the controller on the selected IP and 255.0.0.0 subnet mask*

User interface

Basic GUI buttons

- Save 
- Cancel 
- set UP/DOWN  
- Back to the 'Home screen' 
- ON/OFF 

Main screen

The main screen appears after the unit boot.

- Unit ID
- Current IP
- ArtNet Net and SubUniverse no.
- sACN universe no.
- Version ID
- Settings icon
- Help/User manual icon 
- Notification bar on the screen bottom
 - Art OFF / ArtNet turned off in in the 'Protocols' menu
 - Art-MD NO / ArtNet server not found on the network
 - Art-MD OK / ArtNet server is on the network
 - Art-STRM / valid incoming ArtNet stream



Protocols:



- ArtNet ON/OFF
- sACN ON/OFF
- LedStripStudio2 ON/OFF
- SegmentSize: set the number of physical LED's that you wish to control by one RGB pixel's three (3) DMX channel. (1, 3, 6, 10, 30, 50, 60, 100, 120, 1000)

Example:

- *When you want to save DMX parameters on your control network, just set it to 2 or higher and you get smaller pixel groups or set it to '1000' and get a simple 3DMX ch RGB line.*
- Pixel overlap thru universes ON/OFF: Skip the last 1 or 2 dmx channels if a complete RGB pixel cannot fit on the universe.

Network:



- Set IPv4 address
- Set Subnet mask
- ArtNet Net Net: 0 - 127 and SubUniverse: 0-255

Example

Here is an example If you have separated net, subnet and universe setup on your controller:

- *Set the universe 0: Net 0, Sub.uni. 0*
- *Set the universe 17: Net 0, Sub.uni. 17.*
- *Set the universe 255: Net 0, Sub. uni. 255.*
- *Set the universe 256: Net 1, Sub. uni. 0.*

- *Set the universe 500: Net 1, Sub. uni. 244.*

- sACN universe no. 1-63,999

Manual:

- Test animations



System:

- CRE:ON ID settings:
Set your preferred ID number for the CRE:ON to get a node ID when make large scale events. The ID appearing in the ArtNet node description as CREON-[ID].
- Auto display sleep after 60seconds ON/OFF. - wake up the unit with one tap on the screen
- 'Firmware update'



Example

1. *Connect the CREON to a LAN with internet connection and use DHCP IP addressing on the network.*
 2. *Tap on the 'Firmware update' button,*
 3. *Wait until the unit restart, it may take a few minutes.*
 4. *Check the version no. on the main screen.*
- Remember to sign up at <https://subscribe.ledblade.com/creon> for our firmware updates newsletter!



Don't disconnect the internet and don't turn off the unit while the update is running!

CRE:ON HD Technical Specifications

Dimensions	
L x W x H	302 x 157 x 96mm
Weight	3700g
Mounting	2x M8x15mm
Main input	100-240V @50-60Hz
Power	320W
Operational temperature	-20 to +60 Celsius
Rating	IP33
Color	outdoor, matt black, macro texture
Output no	1
Max no. of pixels	1000
Output voltage	24VDC
Connectors	RJ45, XLR, PowerCon true1
Touch screen	2,8" resistive
Known control protocols	LSS, ArtNet, sACN,

Art-Net™ Designed by and Copyright Artistic Licence Holdings Ltd



Connecting diagram

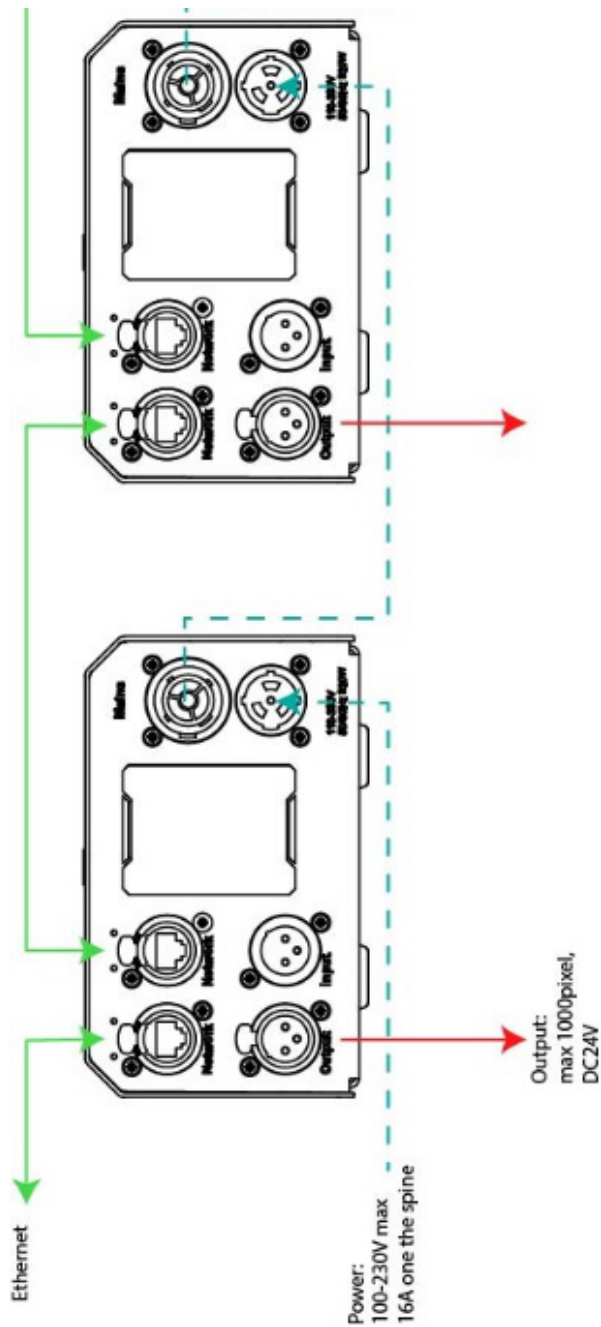

LED **BLADE**

Much more than a LEDSTRIPE

www.ledblade.com