

**DIGITAL SYNTHESIS – MONO/STEREO/INTERCOM MODULATION  
HIGH PERFORMANCE DSP AUDIO PROCESSING**

### Main Features

- 330 MHz Bandwidth
- Direct Digital Synthesis (DDS) of signal for the highest flexibility and quality
- Stereo, mono, intercom audio modulation
- DSP audio processing (40bit floating point / 2Gflops) with multi-companing
- Low interference output stage with wideband intermodulation phase cancellation
- 2400 user-defined frequencies (40 group by 60 freq.)
- Analogue & digital input (AES3)
- Output power up to 2 Watt (/2W0 option)
- Redundant power supply 230/110 Vac & 12 VDC (DC option)
- SWR (Stationary Wave Ratio) sensing on antenna outputs
- master/slave board for iso-frequency transmissions (MS option)

### Description

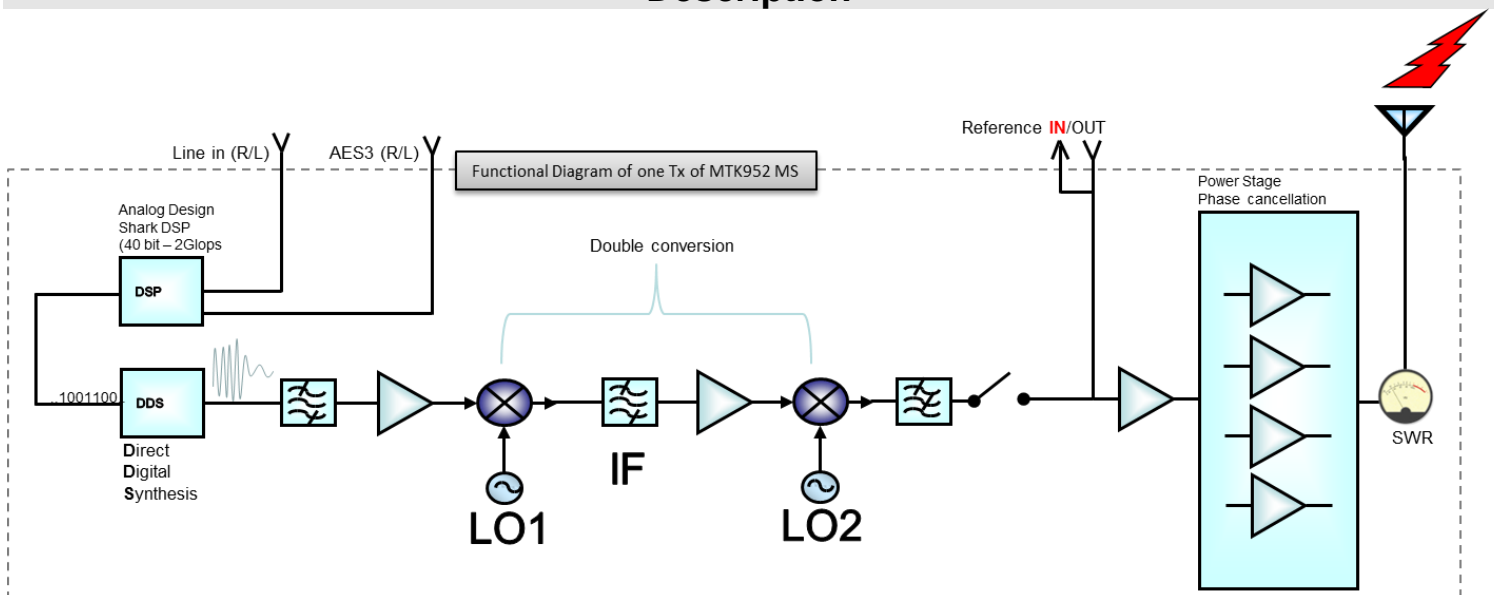

MTK952 is a versatile dual transmitter capable of working in a huge UHF bandwidth and of generating any kind of narrow-band modulations, with very high quality and low spurious emissions.

As described on above diagram, MTK952 use extreme technologies like:

- A. Direct Digital Synthesizer (DDS)
- B. Double conversion stage
- C. Intermodulation cancelling power amplifiers
- D. Digital audio with Shark™ DSP 40bit floating point & 2 Gflops power from Analog Device

### A. True digital waveform generation

DDS is a type of frequency synthesizer used for creating arbitrary waveforms from a single, fixed-frequency reference clock. A DDS has many advantages over its analog counterpart, the phase-locked loop (PLL), including much better frequency agility, improved phase noise, and precise control of the output phase across frequency switching transitions.

The **D**irect **D**igital **S**ynthesis (DDS) technology can generate virtually any kind of modulation while keeping an absolute phase accuracy.

### B. Double Conversion Stage

Using a double conversion and saw filter at IFs (intermediate frequencies) we can achieve a very low spurious emission and a great bandwidth agility (330 MHz).

### C. Intermodulation Cancelling

PA module (power amplifiers) is designed with an exclusive circuitry that reduce the intermodulation generated by external carriers using a wideband phase cancelling design.

### D. True digital waveform generation

A very powerful Analog Design Shark DSP processor manages the audio with very low delay (< 1 ms) and emulates by software all companding and pre-emphasis effects.

MTK952 can be used in broadcasting, theatre, ENG applications delivering top class features.

It can be a very high quality stereo MPX transmitter, or generate a wideband mono link;

it can be a used also with intercom carrier generating also the CTCSS tones:

Audio Profile	Mono/ Stereo	Componder type	High pass filter (flat, 20, 40 60, 80, 120, 170, 250, 300 Hz)	Low pass audio filter (3K, 4K, 12K, 15K, 20K)	Pre emphasys (0, 10, 50, 75, 300, 750 us)	FM Peak deviation (2KHz to 100KHz)	Tone squelch freq (30Hz-260Hz and 18KHz- 38KHz)	Tone squelch deviation (OFF, 100Hz to 5KHz)
ENR-Wisy Stereo	Stereo	ENR	flat	15K	50us	48	NO	OFF
ENC-Wisy Stereo	Stereo	ENC	flat	15K	12us	48	NO	OFF
ENR-Wisy	Mono	ENR	flat	20K	50us	56	32789	OFF/2.6K
ENC-Wisy	Mono	ENC	flat	20K	12us	56	32789	OFF/2.6K
IFB-Wisy	Mono	ENC	flat	12K	75us	40	19000	OFF/3.5K
COM-Wisy 25K	Mono	NR	300	4K	0us	4,5	131,8	OFF/700Hz
COM-Wisy 20K	Mono	NR	300	4K	0us	4	131,8	OFF/700Hz
COM-Wisy 12k5	Mono	NR	300	3K	0us	2,3	131,8	OFF/350Hz
USER	Mono	None	flat	20K	50us	56	NO	OFF/100-5000

fixed
user



**Before putting the device into operation, please observe the respective country-specific regulations**

**TECHNICAL SPECIFICATIONS**

Switchable channels	2400 allocated by 40 groups of 60 channels quickly selectable with dedicated buttons		
Frequency bandwidth	470-800 MHz		
Switching bandwidth	330 MHz tuneable in 5 kHz steps		
Temperature range	-10 ÷ +55 °C		
RF output power	Selectable: 10,20,50,100,200 mW (ERP) for MTK952-0W2		
Max RF output power	MTK952N-0W2: 200mW MTK952N-2W0: 2Watt [NOTE] RF power can be limited on frequency base accordingly to specific country restrictions (software based)		
“TX1” / “TX2” antenna output	with BNC type female connectors (for MTK952) with N type female connectors (for MTK952N)		
M-S I/O	2xBNC type female connectors (only for MTK952N with MS option)		
RF impedance	50 Ω		
Spurious emissions	< 2 nW (in the transmitter bandwidth)		
Modulation	FM, MPX Stereo or mono, selectable with dedicated menu		
Peak deviation	±56 kHz for mono, ±48 kHz for stereo (preset mode) NOTE: custom setting can set peak deviation from 2kHz to 100kHz		
MPX Pilot tone	19kHz		
Tone squelch	32.789Hz (for Wisycom wireless microphone, i.e. ENR/ENC) 131,8 (for Wisycom intercom, i.e. NR) NOTE: custom setting can change the Tone squelch (30-260Hz and 18-38KHz)		
Frequency response	20÷20kHz (mono) 30÷15kHz (stereo) NOTE: custom setting can change audio bandwidth (3/4/12/15/20kHz)		
<b>Analogue audio input</b>		<b>Monitor output</b>	
Connector type	XLR-3 / 1/4" (6,3mm) jack combo socket, electronically balanced	Connector type	6.35mm (1/4") jack socket, balanced
Max. input level	+18dBu	output level	120+120mW@24Ω , 80+80mW@150Ω
Pin Assignments	XLR: 1=ground 2=hot 3=cold 6.35mm (1/4") TRS: Tip=hot Ring=cold Sleeve=ground	out impedance	25Ω for auricle
<b>Digital audio input</b>	AES3 on XLR-3M (32kHz ±108 kHz)		
Compander	ENR (Wisycom Extended-NR), with independent Attack- and Recovery-time, noise optimized ENC (Wisycom Extended-NC), with independent Attack- and Recovery-time, voice optimized & with reduced pre-emphasys NONE-d50, no compander, pre-emphasis 50 μs NR, to work with Wisycom Intercom system Other compander on request		
Display	64 x 256 OLED (yellow)		
Configuration/monitor interfaces	10/100 Base TX Ethernet port on RJ45 connector		
Power supply	90 - 264 V AC, 50/60 Hz option DC: 10÷19 VDC (NOTE: increased to 10÷28 Vdc since May 2015), Max 7A		
Dimensions	19"/1U 483 x 407 x 43,8 mm (WxDxH) with brackets		
Weight	3.8Kg (version 200mW with DC and MS options); 4Kg (version 2Watt with DC and MS options)		

**RF POWER PROFILE:**
**0W2** max power 200mW (Europe)

**2W0** max power 2W (Europe)

**option:**
**DC** Vdc

**MS** MasterSlave

**COUNTRY POWER PROFILE :**
**EU** Europe (max power 50mW)

**EUX** Europe (max power 200mW for RF Power **0W2**)  
(max power 2Watt for RF Power **2W0**)

**US** USA & Canada , 470-608/614-698MHz  
max power 200mW for RF Power: **0W2**  
max power 250mW for RF Power: **2W0**
**JP** Japan (max power 10mW, limited to 714MHz)

**NZ** New Zealand (max power 500mW, 502-698MHz)

**AU** Australia (max power 100mW(EIRP), 520-694MHz)

For the commercial code, see in the Variants area of the Products on our website