



VENUE | S6L Handbook

VENUE S6L Systems	VENUE Hardware Overview	Hardware and Expansion	Resources: Support	Specifications: Weight
Additional Requirements	Configuration 1	E6L Engine	Resources: Training & Documentation	Specifications: Power ●●●●
VENUE Software	Configuration 2	E6L Engine Options	Resources: Social	Specifications: Dimensions ●●●●●
VENUE Plug-Ins	Configuration 3	Stage 64 I/O Rack		Cable Requirements
iLoks and Licenses	Configuration 4	Stage 64 Expansion Options		Other VENUE Systems
VENUE Standalone Software	Dual Systems with I/O Sharing	Stage 16 I/O		
Pro Tools for S6L	Configurations with Stage 16 I/O	S6L Control Surface		
Pro Tools AVB Record/Playback		Personal Monitoring ●●		
MADI Record/Playback				

VENUE | S6L Systems

Avid VENUE | S6L is a modular live mixing system that delivers unrelenting performance and reliability through its advanced engine design, highly efficient touchscreen workflows and easy scalability. Like all VENUE systems, S6L provides onboard industry-standard plug-ins and Pro Tools integration, with more processing power and track counts than ever before. Plus, with a comprehensive array of network and I/O offerings, including personal monitoring control via [VENUE | On-Stage](#), you can easily configure the system for any application.

Along with the familiar [VENUE software](#), VENUE S6L systems consist of the following hardware components:

1x **S6L Control Surface:** S6L-32D, S6L-24D, or S6L-24C



S6L-32D

-or-



S6L-24D

-or-



S6L-24C



1x **E6L Engine:** E6L-192, E6L-144, or E6L-112, with 1x AVB-192 Network Card

(One additional AVB-192 card is included (but not pre-installed) with some systems, such as the S6L-24C – 112 Stage 16.)



Stage I/O Units:

Stage 64 (base configuration)

- 48 analog in (via 6x SRI cards)
- 8 analog out (via 1x SRO card)



Stage 32 (base configuration)

- 24 analog in
- 8 analog out



Stage 16

- 16 analog in
- 8 analog out
- 4 AES digital output channels



For information on Stage 16 and other expansion options, see [VENUE Hardware Overview](#).

Additional Required Items

The following items are required and must be purchased separately.

For the most up-to-date list of required items, see the S6L Support FAQ on our Knowledge Base:

<http://avid.force.com/pkb/articles/faq/Avid-S6L-Support>

DVI-D Monitor, Trackball/Mouse, Keyboard, and Other

For Day-to-Day Operation:

- Free-standing HDMI or DVI-D compatible Full HD display with 1920 x 1080 minimum resolution (21.5-inch or greater touch display recommended), a DVI-D cable, and a USB cable (for enabling the touch screen function on the monitor).

Note: Use a qualified monitor with your S6L system. Visit

www.avid.com/S6Lsupport for a list of supported monitors and important cable specifications.

Do not use a USB-powered monitor with your S6L system.

- USB keyboard and mouse/trackball (Windows-compatible recommended)

For Software Installation:

The following items may be required for software installation.

- Windows-compatible USB keyboard and mouse (required for software installation, and highly recommended for operation)
- USB flash drive(s) for transferring the S6L plug-ins installer
- An active hard-wired Internet connection
- A separate computer running Windows XP or higher
- A VGA-compatible monitor is required for performing a VENUE software System Restore on the E6L engine (optional for installing a Software Update)

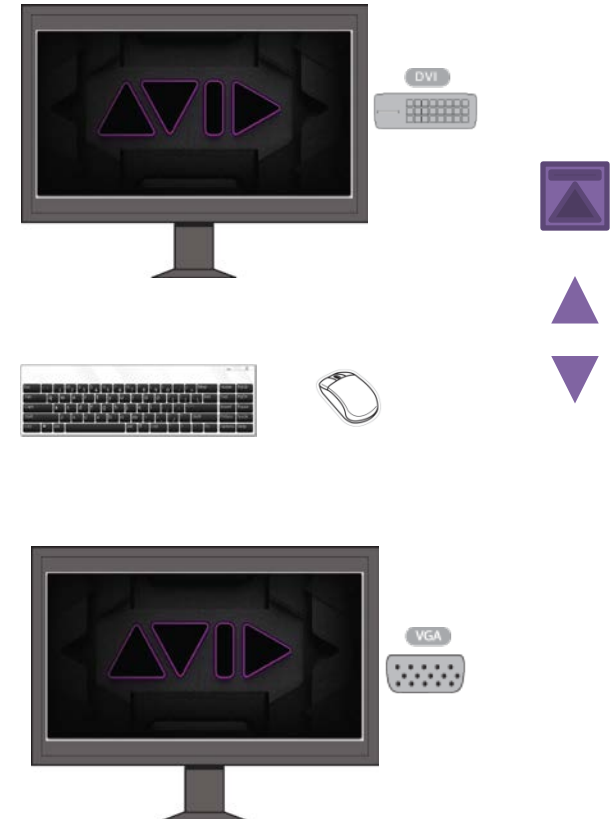

Cables

For details on cable requirements and support, see [Cabling Requirements](#).

VENUE Software

Activation

You must activate each S6L system component using the Activation Card included in each component's shipping package. You must also activate Pro Tools using its Activation Card included in the E6L Engine package.

Follow this link to the S6L Learn & Support home page and scroll down to **TUTORIALS** for a video showing how to install and activate VENUE software:

[Installing & Activating VENUE Software](#)



Once you have completed the activation process for all S6L system components, download links for all S6L system software and documentation are available from the <My Products and Subscriptions> section of your Avid account. These items remain in your account after you have downloaded them, in case you need to access them again.

<https://www.avid.com/account>

VENUE software downloads include the following primary elements:

- System Restore for E6L Engine
- System Restore for S6L Control Surface
- Software Update (updates both the E6L Engine and S6L Control Surface)

Notes:

- When performing a System Restore you *MUST* download and perform both System Restores (E6L Engine and S6L Control Surface).
- Software Update downloads are available whenever possible, but may not be available for every release. If no Software Update is available, download and perform both System Restores.
- For complete instructions on software installation, including how to backup Show files and settings, see the *VENUE S6L Installation Guide.pdf* (available for download in your account after you Activate).

VENUE Plug-Ins

Each VENUE | S6L System comes with an extensive collection of software plug-ins. Many more are available from Avid and our Development Partners.

VENUE plug-ins let you mix with the same sound processors used in top studios to get the sounds you want. Or re-create an artist's signature studio sound live. Because S6L directly supports Avid and third-party 64-bit AAX DSP plug-ins, you have far more creative choices at your fingertips than any other live mixing system. Plus, you can use many more plug-ins in your mix, thanks to the system's dedicated, scalable HDX-powered DSP processing.

<http://www.avid.com/products/venue-s6l-system/included-plugins>

For a list of some of the plug-ins compatible with S6L, see:

[S6L Plug-In Compatibility](#)



Waves SoundGrid

By installing a [WSG-HD Waves SoundGrid Option Card](#) into the E6L engine you can integrate a Waves SoundGrid server hosting Waves plug-ins directly into your S6L system.

Activating your VENUE system deposits iLok licenses in your iLok account.

Activating Pro Tools deposits additional licenses into your iLok account.

Visit iLok.com to sign-in to your iLok account, or create one if necessary (it's free). Download and install the *iLok License Manager* on a Mac or PC to be able to install and manage your licenses.

Use iLok License Manager to transfer the following licenses to the correct iLok:

VENUE Plug-in Licenses (such as S6L Plug-In Bundle) VENUE plug-in licenses must be transferred to your VENUE iLok (the licenses must be present on an iLok connected to your VENUE system).

LiveSound Production Toolkit Beginning with Pro Tools 2018.9, the functionality provided by the Live Sound Production Toolkit is included in Pro Tools and is automatically enabled whenever the Pro Tools Playback Engine is set to E6L (or E3). For maximum compatibility, transfer the Live Sound Production Toolkit to your Pro Tools iLok to enable 64- and 128-channel Pro Tools AVB with Pro Tools 2018.7 or earlier.

Pro Tools Your Pro Tools license must be transferred to your Pro Tools iLok alongside the licenses for any Pro Tools plug-ins, and the LiveSound Production Toolkit license (if using Pro Tools 2018.7 or earlier).

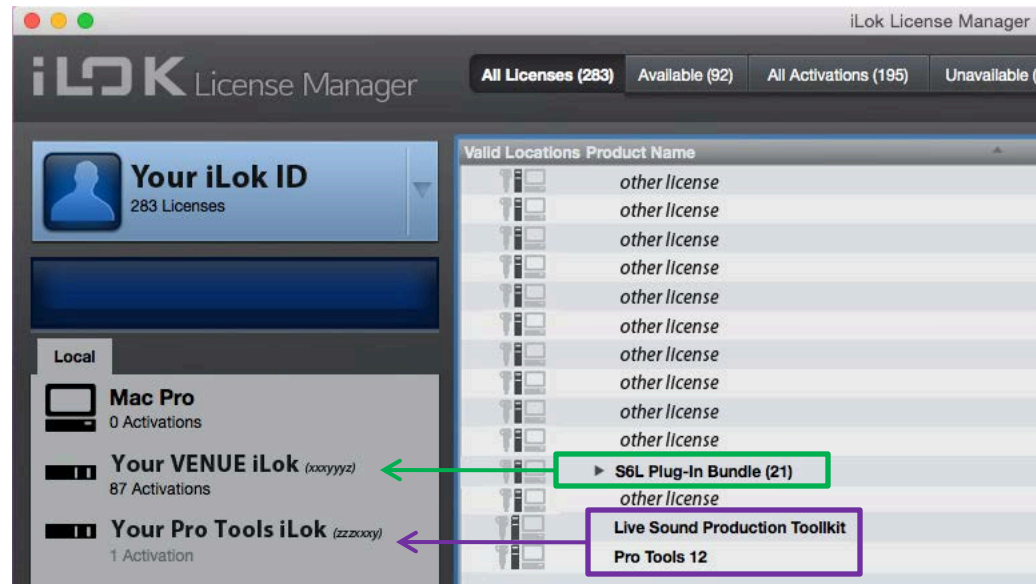

Example iLok account shown in iLok License Manager



iLok (2nd generation)



iLok (3rd generation)

VENUE Standalone Software

VENUE | S6L Standalone software is free and available for download from our Knowledge Base:

<http://avid.force.com/pkb/articles/download/VENUE-Standalone-Software-Updates>

S6L Standalone software lets you do all of the following:

- Learn the basics of the VENUE | S6L software interface to prepare for working at a full VENUE | S6L system.
- Assign hardware I/O and routing, and name channels.
- Set channel input, EQ, dynamics, pan, and other settings.
- Create and maintain a library of setups, with access to nearly all parameters available on the control surface.
- Store and recall Snapshots, and configure Events.
- Use the Filing features to transfer Shows and Shows Folders, as well as channel, processing and plug-in presets to/from a compatible USB storage device to transfer data between the standalone software and VENUE | S6L systems. You can also import snapshots and events from one Show into the current Show file (requires VENUE software version 5.7 or higher).

For system requirements and installation instructions download the *S6L Standalone Software.pdf*

For examples and tutorials that can be performed in the Standalone software, download the *Intro to S6L.pdf*

http://avid.force.com/pkb/articles/user_guide/S6L-Documentation

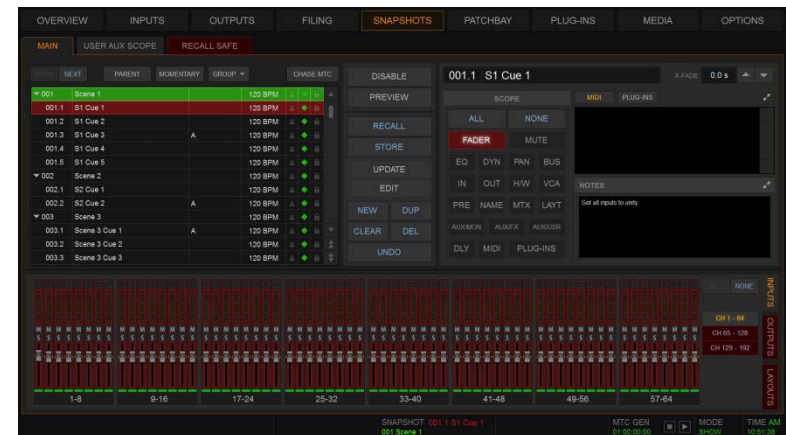
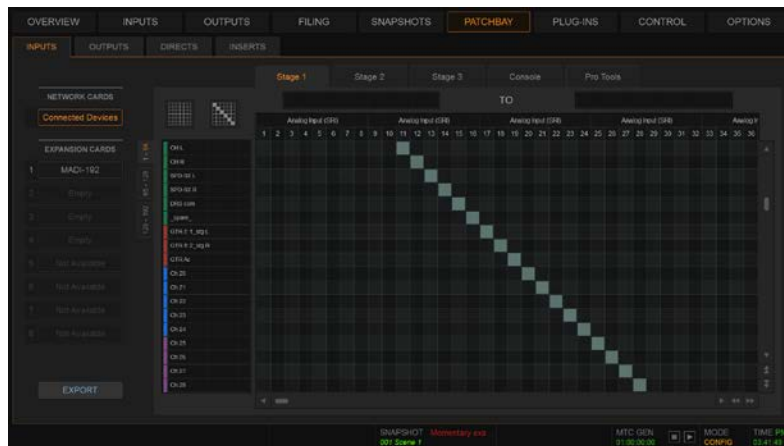



Pro Tools for S6L

Each VENUE | S6L System includes Pro Tools and a Pro Tools [iLok](#). Pro Tools Activation and download links are provided in the E6L Engine package. Use these to activate and download Pro Tools Software from your Avid Account to your compatible workstation.

Important!

For the latest compatibility information, Mac optimizations and other system requirements to use Pro Tools with S6L, refer to this article on our Knowledge Base: [What are the system requirements for Pro Tools with S6L?](#)

When you Activate Pro Tools, its required iLok asset (license) is transferred to your iLok.com account, along with licenses for any included plug-ins. You must then transfer your **Pro Tools** license and any **Pro Tools Plug-in** licenses to your Pro Tools iLok.

Important: Live Sound Production Toolkit Beginning with Pro Tools 2018.9, the functionality provided by the Live Sound Production Toolkit is included in Pro Tools and is automatically enabled whenever the Pro Tools Playback Engine is set to E6L (or E3). For maximum compatibility, be sure to also transfer the Live Sound Production Toolkit license to your Pro Tools iLok to enable 64- and 128-channel Pro Tools AVB with Pro Tools 2018.7 or earlier.

About Virtual SoundCheck

When using Pro Tools with S6L via [Pro Tools AVB](#) or [MADI Record/Playback](#) (requires one or more MADI-192 MADI Option Cards) you get complete Virtual SoundCheck functionality. With Virtual Soundcheck you can get a head start on your mix using Pro Tools recordings from a previous night's performance in place of the live mics. Play back the tracks from a previous performance, adjust the mix, program snapshots and experiment with different plug-ins, and have your changes remain when you switch back to your live mix.

About VENUELink

VENUELink is a communication protocol that lets you take advantage of the following capabilities:

- Control the Pro Tools transport directly from the S6L control surface.
- Create Pro Tools sessions that automatically populate and name tracks based on VENUE channels.
- Create and link Pro Tools Makers (memory locations) with VENUE Snapshots.
- VENUELink uses the same Ethernet connection to the Pro Tools computer as Pro Tools AVB.

To learn how to integrate Pro Tools recording and playback into your shows with S6L, download the *S6L Live Recording Guide.pdf*:
http://avid.force.com/pkb/articles/user_guide/S6L-Documentation





Pro Tools AVB Record/Playback

Pro Tools AVB

The S6L system provides direct connection to a computer running Pro Tools software. No additional audio hardware is required to connect your S6L system to Pro Tools.

A single Ethernet connection lets you record multi-track Pro Tools sessions of performances using a variety of S6L system audio sources, including digital splits of your Stage inputs, channel Direct Outputs, and bus outputs. You can also play back multi-track audio from Pro Tools through your S6L system to integrate pre-recorded tracks with your live mix, or to monitor your Pro Tools recording on your S6L system. By combining recording and playback features, you can perform a true Virtual Soundcheck.



Summary:

- Works out-of-the-box.
- Single Ethernet connection to Pro Tools (Network port **C** on S6L Control Surface to the Pro Tools computer).
- Supports up to 128-channel communication with Pro Tools 2018.9 or later and a compatible Pro Tools workstation.
- With Pro Tools 2018.7 and earlier, supports 32 channels of bi-directional audio by default; 64- and 128-channels supported with the LiveSound Production Toolkit license on your Pro Tools iLok, and a compatible Pro Tools workstation.
- 128-channel AVB also requires 2x AVB-192 Network Cards in the E6L Engine.
- Can do splits and/or sub-mixing/stems, supports VENUeLink and true Virtual SoundCheck.

Requirements:

- If you are using Pro Tools 2018.7 or earlier, both the Pro Tools license *and* LiveSound Production Toolkit licenses *must* be present on the Pro Tools iLok. Both of these licenses are included with the shipping system (if you are renting a system, be sure the Pro Tools iLok with these licenses is included). Beginning with Pro Tools 2018.9, the functionality provided by the Live Sound Production Toolkit automatically enabled whenever the Pro Tools Playback Engine is set to E6L (or E3).
- 128-channel AVB requires 2x AVB-192 Network Cards in the E6L Engine.
- Special system requirements for the Pro Tools computer may apply depending on the number of channels. For the latest compatibility information and system requirements, visit this article on our Knowledge Base:

[What are the system requirements for Pro Tools with S6L?](#)

For examples and step-by-step instructions, download the *S6L Live Recording Guide.pdf*:

http://avid.force.com/pkb/articles/user_guide/S6L-Documentation

MADI Record/Playback

In addition to Pro Tools AVB, you can also use either (or both) of the following MADI solutions:

MADI-192 MADI Option Card

- Requires one or more MADI-192 MADI Option Cards (sold separately) installed in the E6L Engine.
- Great for redundant recording, can do splits and/or stems.
- Supports 48k recording (via SRC on the receiving MADI device).
- Requires one or more Pro Tools | HD MADI IO interfaces, or similar MADI-compatible devices.
- Because the [MADI-192 MADI Option Card](#) provides MADI inputs and outputs, Virtual SoundCheck is supported.

Stage 64 MADI Splits

- Works out-of-the-box. Each Stage 64 and Stage 32 includes MADI Out connectors for up to 64 MADI channels on Stage 64 and up to 32 on Stage 32.
- Supports direct digital splits of inputs (1-to-1 split of all Stage inputs; no sub-mixing or stems)
- Great for redundant multi-tracking to Pro Tools or other MADI devices (1-to-1 split of Stage inputs only).
- Supports 48k recording (via SRC on receiving MADI device).
- Does not support Virtual SoundCheck (no MADI inputs on Stage 64 or Stage 32).
- Requires one or more Pro Tools | HD MADI IO interfaces, or similar MADI-compatible devices.

For more information, download the *S6L Live Recording Guide.pdf*:

http://avid.force.com/pkb/articles/user_guide/S6L-Documentation



VENUE Hardware Overview

VENUE | S6L systems are shipped in the following base configuration.

1x S6L Control Surface (S6L-32D, S6L-24D, or S6L-24C)

1x E6L Engine (E6L-192, E6L-144, or E6L-112) with 1x AVB-192 Network Card. Some system configurations include a 2nd AVB-192 Network Card.

1 or more Stage I/O Units (Stage 64, Stage 32, Stage 16)

- Additional Stage 64s (up to 3x) can be connected simultaneously (3x requires two AVB-192 Network Cards).
- Stage 16 I/O boxes can also be used with S6L systems (requires two AVB-192 Network Cards).
- Stage 32 I/O units can also be used with S6L systems (requires two AVB-192 Network Cards).
- AVB-192 Network Cards, IO units, and I/O cards for Stage 64 and Stage 32 are sold separately.
- Additional IO Option cards such as the MADI-192 MADI Option Card and WSG-HD Waves SoundGrid Option Card can be added to the E6L Engine.

Example System Configurations, Stage I/O Capacity, and Connection Diagrams

Here are a few example S6L system configurations including single systems, single system expanded IO, Dual System/IO Sharing setups, and configurations with Stage 16s. Follow the “Configuration” links for connection diagrams and additional information on the following pages.

Configuration	Stage Inputs (max)	Stage Outputs (max)	AVB-192 Network Cards in E6L Engine (required)
Configuration 1 Base Configuration 1x Stage 64	64	32	1
Configuration 2 Single System 2x Stage 64	96	64	1
Configuration 3 Base Configuration 3x Stage 16	48	24 analog plus 12 digital	2
Configuration 4 Single System Expanded I/O	192	96	2
Configuration 5 Dual Systems for I/O Sharing	192	96	2
Mixed Configurations with Stage 64s and Stage 16s	varies		2



Configuration 1

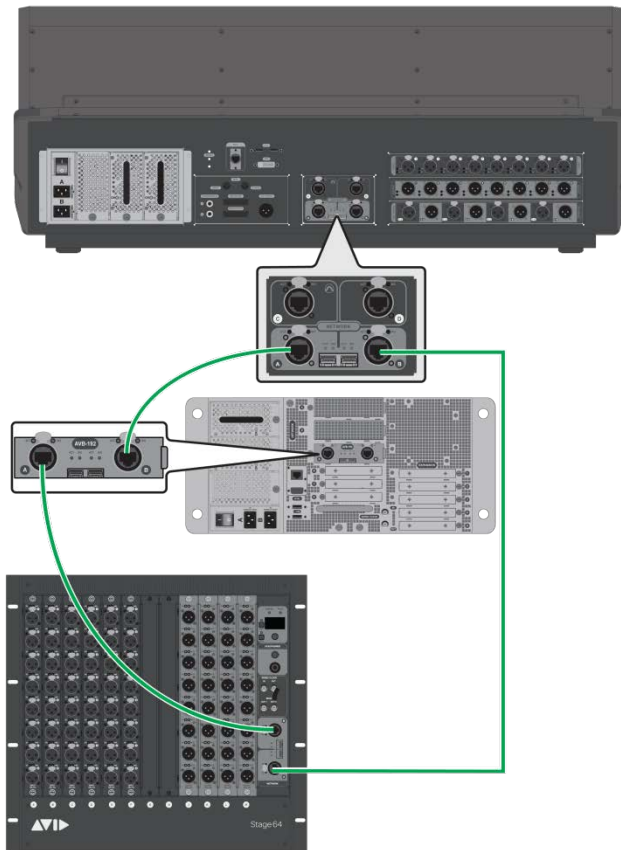

Maximum IO Capacity:

Up to 64 Stage Inputs, and up to 32 Stage Outputs

Requirements for Maximum I/O:

- 1x Stage 64 (8x 8-ch Input cards, 4x 8-ch Output cards)
- 1x AVB-192 Network Card in E6L

Connections

All connections are made between an “A” port and a “B” port. Examples (shown at left):

- S6L Network port A connects to port B on the E6L.
- E6L port A connects to Stage 64 port B.
- Stage 64 port A connects to S6L Network port B.



Configuration 2

Single System with 2 Stage 64s

Maximum IO Capacity:

Up to 96 Stage Inputs, up to 64 Stage Outputs

Requirements for Maximum IO:

- 2x Stage 64s, each with:

Up to 6x 8-ch Input cards

Up to 4x 8-ch Output cards

(Maximum capacity for both Stage 64s. Higher I/O capacity requires two AVB-192 Network Cards in the E6L Engine.)

Connections

All connections are made between an “A” port and a “B” port.

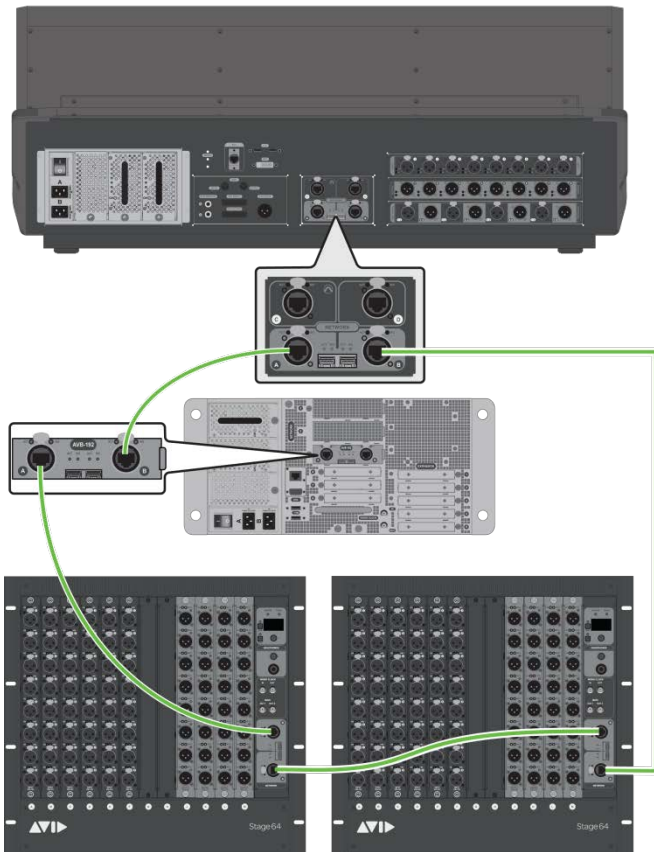

Configuration 3

Single System with 3 Stage 16s

Base Configuration:

48 analog Stage Inputs, 24 analog Stage Outputs, 12 Stage Outputs (digital)

Requirements:

- 2x AVB-192 Network Cards in E6L (included with S6L 24C-112 Stage 16 systems)

Connections

All connections are made between an “A” port and a “B” port.

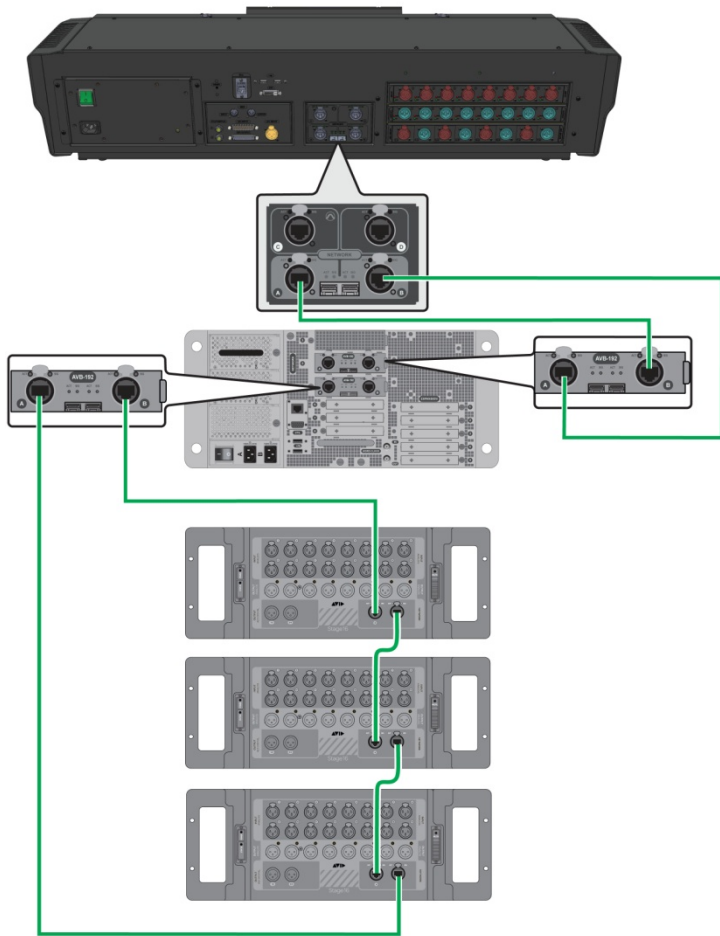

S6L-24C – 112 (Stage 16) System



Configuration 4

Single System Expanded I/O

Maximum Expanded IO Capacity:

Up to 192 Stage Inputs, up to 96 Stage Outputs

Requirements:

- 2x AVB-192 Network Cards in E6L Engine
- 3x Stage 64s, each with:
 - Up to 8x 8-ch Input cards
 - Up to 4x 8-ch Output cards

Connections

All connections are made between an “A” port and a “B” port.

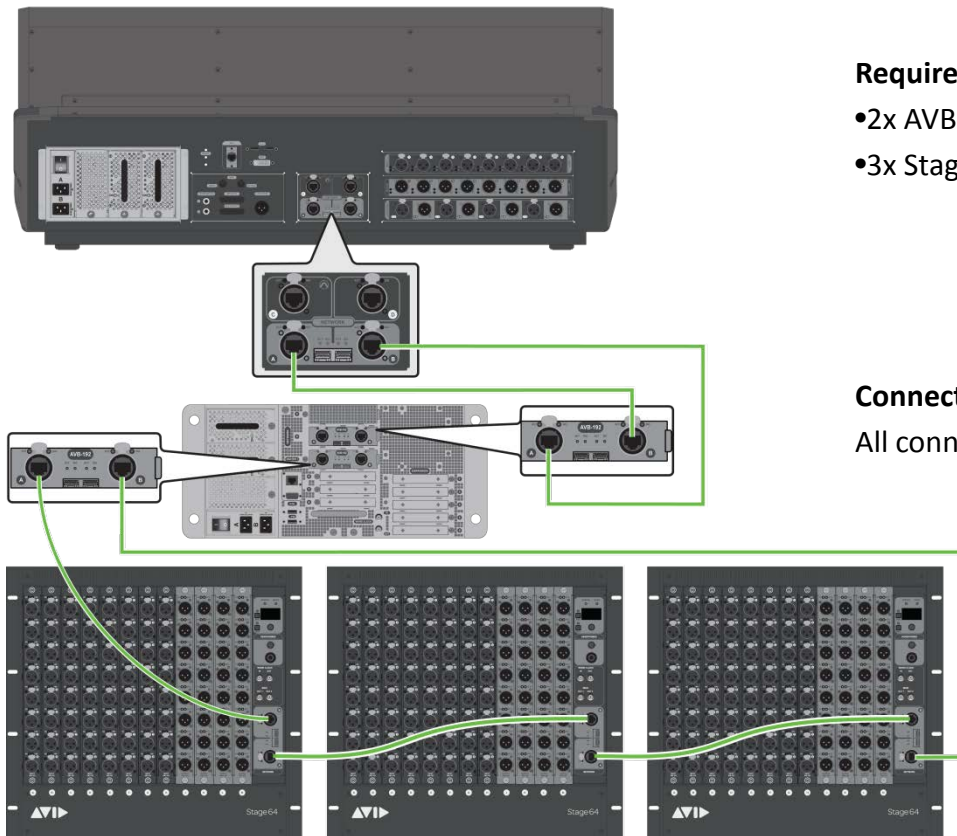

Configuration 5

Dual Systems with I/O Sharing

Maximum Expanded IO Capacity:

Up to 192 Stage Inputs, and up to 96 Stage Outputs

Requirements:

- 2x S6L Control Surfaces
 - 2x E6L Engines, each with 2x AVB-192 Network Cards
 - Up to 3x Stage 64s, each w/ up to 8x 8-ch Input cards, and up to 4x 8-ch Output cards
- Stage 64 Inputs can be shared per-Stage 64; Outputs can be shared per-Output Card.

Connections All connections are made between an “A” port and a “B” port.

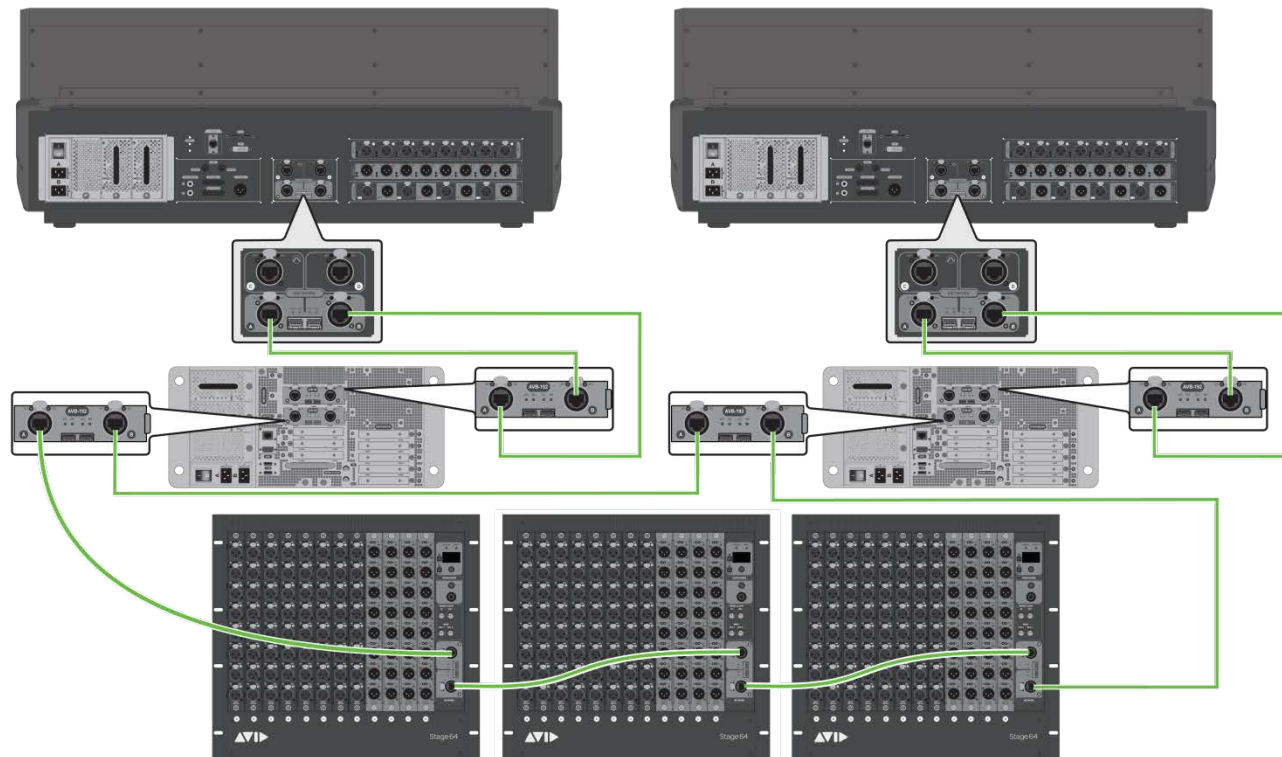

Mixed Configurations with Stage 64 and Stage 16

You can use VENUE Stage 32 IO units (requires VENUE software 6.0 or later) and Stage 16 IO boxes with S6L systems (requires VENUE software 5.5 or later).

Here are example diagrams of supported configurations with Stage 16s.

Requirements: 2x AVB-192 Network Cards in E6L Engine(s)

Connections: All connections are made between an “A” port and a “B” port.

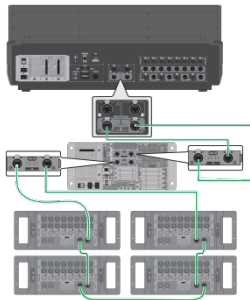

Maximum I/O Capacity:

- 64 Stage Inputs
- 48 Stage Outputs

Requirements:

- 2x AVB-192 Network Cards in E6L Engine
- 4x Stage 16s

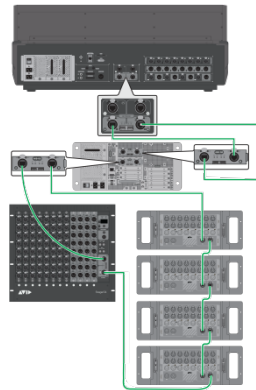

Maximum I/O Capacity:

- 128 Stage Inputs
- 80 Stage Outputs

Requirements:

- 2x AVB-192 Network Cards in E6L Engine
- 1x Stage 64
- 4x Stage 16s

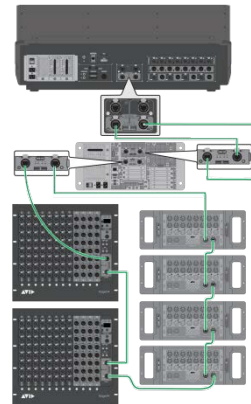

Maximum I/O Capacity:

- 192 Stage Inputs
- 112 Stage Outputs

Requirements:

- 2x AVB-192 Network Cards in E6L Engine
- 2x Stage 64
- 4x Stage 16s

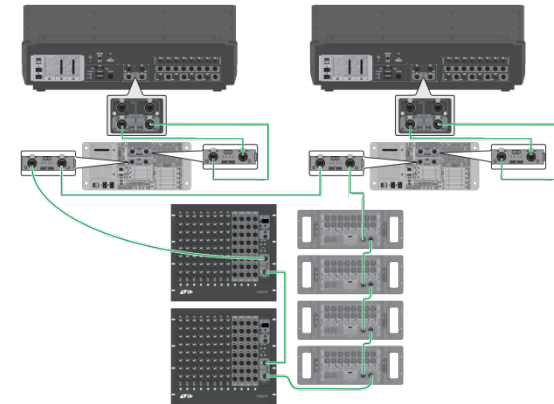

Dual Systems with I/O Sharing

Maximum I/O Capacity:

- 192 Stage Inputs
- 112 Stage Outputs

Requirements:

- 2x AVB-192 Network Cards in both E6L Engines
- 2x Stage 64
- 4x Stage 16s



Hardware Components and Expansion Options

Follow the links below for descriptions of each S6L hardware component and available expansion options.

S6L hardware components can be expanded for increased plug-in processing, local or stage I/O, and screen interaction.

[E6L Engine](#)



[Stage 64 I/O Rack](#)



[Stage 32](#)



[Stage 16](#)



[S6L Control Surface](#)



E6L Engine

E6L Engines are available in three configurations, E6L-192, E6L-144, and E6L-112.



The following table describes the capabilities of each E6L Engine.

Engines	Input Channels	Mix Busses	Ethernet AVB (Network)	HDX-192 DSP Cards (Processing)	Option Cards
E6L-192 base configuration	192	96 + LCR	1x AVB-192 Network Card (2x AVB-192 Network Cards included in some systems)	1	Up to 8x Option Cards
E6L-144 base configuration	144	64 + LCR		1	Up to 4x Option Cards
E6L-112 base configuration	112	tbd		1	Up to 2x Option Cards
Maximum per E6L			2x AVB-192 Network Cards **	E6L-192: 4 E6L-144: 2 E6L-112: 2	E6L-192/144: <ul style="list-style-type: none"> Up to 4x MADI-192 Option Cards (64 channels each, for a maximum of up to 256 channels of MADI at 96 kHz) 1x WSG-HD Waves SoundGrid Option Card E6L-112 (only): <ul style="list-style-type: none"> Up to 2x MADI-192 Option Cards (64 channels each, for a maximum of 128 channels of MADI at 96 kHz) 1x WSG-HD Waves SoundGrid Option card (if 1x WSG-HD card, maximum of 1x MADI-192 cards)



****2x AVB-192 Network Cards are required for each of the following:**

- [Single system Expanded I/O](#)
- [I/O Sharing](#)
- [Stage 32 I/O](#)
- [Stage 16 I/O](#)
- [AVB 128-channel Virtual Soundcheck recording/playback](#)

E6L Engine Expansion Options



E6L Expansion Options



AVB-192 Network Cards

Each E6L includes at least one AVB-192 Network Card for connecting the E6L to other components in the system. (Some systems, such as the S6L-24C-112 Stage 16, include two AVB-192 Network Cards.) You can add a second AVB-192 card to expand the IO capability of the system by adding Stage I/O units, to connect multiple systems to utilize I/O sharing (shared stage inputs and gain tracking), and for 128-channel AVB Virtual Soundcheck.

For installation instructions, see the *AVB-192 Network Card Guide*.



MADI-192 MADI Option Cards

The MADI-192 MADI Option Card is a high-channel-count, 96 kHz (only) MADI audio interface card for E6L engines. Each MADI-192 MADI Option Card provides four MADI BNC connectors (2x coaxial in, and 2x coaxial out). Each pair of coaxial MADI inputs and outputs supports up to 32 channels of 96 kHz audio per I/O pair. Up to four MADI Option cards can be installed in an E6L-192 or E6L-144 engine. Up to two MADI Option cards can be installed in an E6L-112 engine.

For installation and operational instructions, see the *MADI-192 Card Installation Guide*.



WSG-HD Waves SoundGrid Option Cards

The WSG-HD Waves SoundGrid Option Card from Avid lets you integrate Waves SoundGrid processing directly into your VENUE | S6L mixes.

Once the WSG-HD Card is installed in your E6L engine, plug-ins hosted on the Waves SoundGrid server appear on the VENUE Plug-Ins screen inside of the Waves SoundGrid Rack plug-in (up to 8 plug-ins per instance of SoundGrid Rack). Up to two compatible Waves SoundGrid servers can be connected simultaneously for redundancy with automatic fail-over. The WSG-HD Card requires VENUE software version 5.7 or higher.

For hardware installation instructions see the *WSG-HD Card Installation Guide*.

HDX-192 DSP Expansion Cards

HDX-192 DSP Expansion Cards provide the DSP resources for plug-in processing. All E6L Engines include a single HDX-192 DSP Expansion Card.

- Up to 4x HDX cards can be installed in E6L-192 Engines
- Up to 2x HDX cards can be installed in E6L-144 Engines
- Up to 2x HDX cards can be installed in E6L-112 Engines

For installation instructions, see the *HDX-192 Card Installation Guide*.

Stage 64 I/O Rack

Each Stage 64 I/O Rack ships from the factory with the following I/O:

- 48 analog inputs (XLR balanced) via 6x SRI Analog Input cards
- 8 analog outputs (XLR balanced) via 1x SRO Analog Output card
- 64 MADi splits (output channels) Coax

Additional inputs and outputs can be added to Stage 64 I/O Racks by installing [Stage I/O Expansion Options](#).

Pairs of Stage 64 analog and digital I/O can be used as hardware inserts (any matched pairs on any cards; Stage 64 MADi outs do not support use as hardware inserts).

Up to 3x Stage 64s can be connected simultaneously (requires 2x AVB-192 Network Cards in the E6L Engine).



Stage 64 I/O Racks can also be purchased empty (no pre-installed I/O cards) to be customized with whatever combination of analog and digital IO is needed.

Stage 32 I/O

Beginning with VENUE 6.0 you can use Avid Stage 32 I/O racks with S6L systems.

Each Stage 32 provides the following I/O in its base configuration:

- 3x SRI cards for 24 analog inputs with remotely controllable mic preamps and individually selectable phantom power
- 1x SRO card for 8 analog outputs
- 32 MADIs (output channels) Coax

Stage 32s are modular and expandable. Analog or digital I/O cards can be installed in any combination up to a maximum of 32 in or 32 out, analog or digital (see [Stage I/O Expansion Options](#)).

Requirements

- To use Stage 32s with S6L systems, two AVB-192 Network Cards must be installed in all E6L Engines.
- No more than two Stage 64s can be connected whenever any Stage 32 is present.



Stage 32 I/O Racks can also be purchased empty (no pre-installed I/O cards) to be customized with whatever combination of analog and digital IO is needed.



Stage I/O Expansion Options

Additional inputs and outputs can be added to Stage 64 and Stage 32 I/O units by installing Stage I/O Expansion cards.

Stage 64 Each Stage 64 I/O Rack has a maximum I/O capacity of:

- 64 analog and/or digital input channels (up to 8x 8-channel Input cards, maximum)
- 32 analog and/or digital output channels (up to 4x 8-channel Output cards, maximum)

Stage 32 Analog or digital I/O cards can be installed in Stage 32s in any combination up to a maximum of 32 in or 32 out, analog or digital.

Here are the available analog and digital I/O cards you can install in Stage 64 and Stage 32:

SRI-192 Analog Input Cards



- Eight channels of analog mic/line inputs via XLR-3 female connectors
- +48V phantom power, 20 dB pad, and phase reverse (all selectable per channel via the control surface and VENUE software)
- Signal and phantom power LEDs for each channel
- 24-bit A/D conversion, up to 192 kHz sample rate

DSI-192 Digital Input Cards



- Eight channels of digital inputs via four two-channel AES/EBU XLR3-female connectors or a single ADAT TOSLINK optical connector
- Automatic sample rate conversion (SRC) and detection on input; manually defeatable for lowest possible input latency
- SRC and Lock status LEDs for both AES and ADAT connections
- Word clock output for synchronizing external digital devices

SRO-192 Analog Output Cards



- Eight channels of analog line outputs via male XLR-3 connectors
- Automatic muting for system protection
- Signal and Mute LEDs for each channel
- 24-bit D/A conversion

DSO-192 Digital Output Cards



- Eight channels of digital outputs via four two-channel AES/EBU XLR3-male connectors and/or a single ADAT TOSLINK optical connector
- Simultaneous output to both AES/EBU outputs and ADAT optical output
- Automatic muting for system protection
- Signal and Mute LEDs for each AES/EBU channel pair

DNT-192 Network Cards



- Sixteen channels of digital input or output, or eight input and eight output channels (Stage 64 only), for connecting to Dante network devices.
- The DNT-192 Network Card supports SRC (sample rate conversion) between the S6L and the Dante network sample rate



For more information on S6L Option cards, visit:

[Avid VENUE | S6L System Options](#)

For S6L documentation, including expansion I/O cards:

[Avid S6L Documentation](#)

Stage 16 I/O

Beginning with VENUE 5.5 you can use Avid Stage 16 I/O racks with S6L systems.

Each Stage 16 provides the following I/O:

- 16 analog inputs with remotely controllable mic preamps and individually selectable phantom power
- 8 analog outputs
- 4 AES digital output channels (on two stereo connectors)

Requirements

- To use Stage 16s with S6L systems, two AVB-192 Network Cards must be installed in all E6L Engines.
- No more than two Stage 64s can be connected whenever any Stage 16 is present.



For descriptions and diagrams of supported setups, see [Configurations with Stage 16s](#).



S6L Control Surfaces

S6L Control Surfaces are available in the following configurations.



CONTROL SURFACE	S6L-32D	S6L-24D	S6L-24C
12-inch daylight-visible touchscreens	1 Master Touchscreen, 3 Channel Touch Modules	1 Master Touchscreen, 2 Channel Touch Modules	1 Master Touchscreen
Faders	32 + 2	24 + 2	24 + 2
Knob Modules with high-resolution OLEDs and tri-color function indicators	96 assignable knobs across 3 Channel Knob Modules	64 assignable knobs across 2 Channel Knob Modules	32 assignable knobs across 1 Channel Knob Module
Master Live Module	Graphic TFTs with soft buttons; Touch and Turn assignable encoder; 2 assignable faders; monitoring, layout and snapshot controls; transport controls and function buttons		
Metering	30-segment meters per channel, with pre- and post-fade metering options; Nominal indicator, Expander/Gate status and Compressor/Limiter gain reduction meters		
Analog inputs	8 XLR mic/line inputs with 48V and signal present LEDs		
Analog outputs	8 XLR outputs with mute and signal present LEDs		
Digital inputs	4 pairs of XLR stereo AES/EBU (8 channels total)		
Digital outputs	4 pairs of XLR stereo AES/EBU (8 channels total)		
Headphone outputs	2 independent 1/4" TRS stereo headphone jacks		
Ancillary I/O	DVI-D video out, 5 USB 2.0 (2 rear, 2 front, 1 internal), ECx Ethernet port for wired/wireless remote control, GPIO (8 in/8 out), 2 footswitch, Linear Time Code input, MIDI I/O		
Ethernet AVB ports	2 etherCON (copper), 2 selectable as etherCON (copper) or SFP (fiber); redundant ring topology		
Power supply	Dual redundant, internal hot-swappable PSUs		Dual redundant, internal
Height (front, rear)	3.6, 15.3 inches (91, 388 mm)		3.6, 8 inches (91, 205 mm)
Width	51.3 inches (1,304 mm)	38.9 inches (989 mm)	38.9 inches (989 mm)
Depth	31 inches (787 mm)		
Weight	155 lbs (70 kg)	119 lbs (54 kg)	84 lbs (38 kg)



For descriptions and diagrams of supported configurations see the *VENUE S6L Installation Guide.pdf*.

Personal Monitoring

Avid VENUE | On-Stage

Personal Mix Control with VENUE | On-Stage

Avid VENUE | On-Stage app for iPad and iPhone lets performing artists remotely control master level, and level and pan of each member channel feeding a selected Aux monitor mix or Mains.

VENUE | On-Stage easily connects to a supported VENUE | S6L (or VENUE | S3L-X) system via Wi-Fi. Using compatible iPads and iPhones, up to 16 instances of On-Stage can be connected simultaneously. Access to mixes can be controlled with passwords.

Installation and Setup

1. On-Stage is available free from [the App Store](#). On each compatible device, search for VENUE On-Stage and click *Get*.
2. Using an Ethernet cable, connect a Wi-fi router to the ECx port on the S6L control surface (or E3 Engine on S3L-X systems).
3. Connect your iOS device(s) to the wireless network associated with the router that is connected to your VENUE system.
4. Launch On-Stage as you would any app on your mobile device (tap its icon). →  On-Stage finds all S6L/S3L-X systems on the Wi-Fi network and displays the Connect screen.

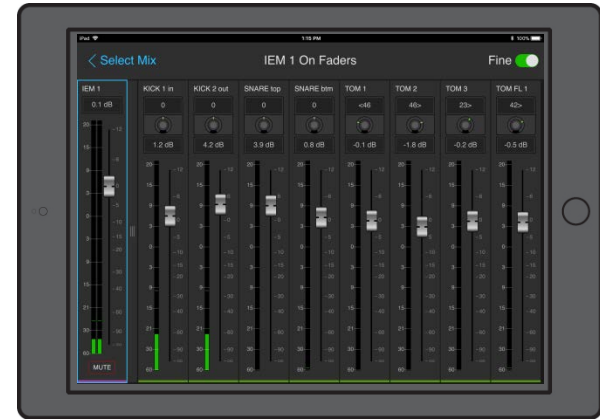
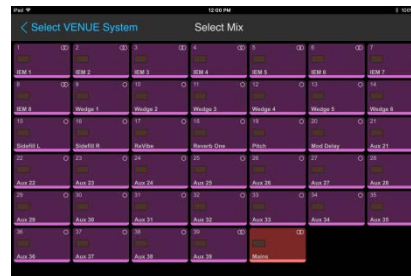
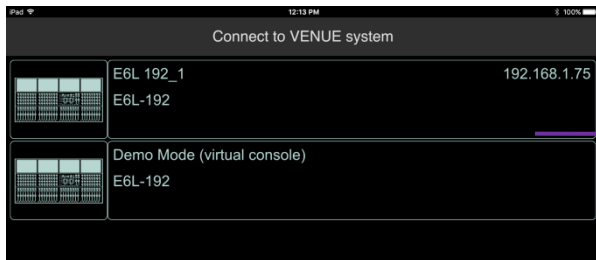

Mix screen for a select Aux

In the Mix screen:

- Drag faders to adjust channel volume. Enable Fine mode for greater resolution.
- To see more channels, swipe right or left.
- To adjust pan, tap a pan display then adjust the on-screen knobs.
- To hide the Master, swipe the “grip” icon to the left (swipe to the right to show a hidden Master).
- To adjust a different mix, tap *Select Mix*.

For more information, see the *VENUE On-Stage.pdf*.

5. On the Connect screen, tap to choose one of the listed systems. The Select Mix screen appears.

(If you don't see your VENUE system listed, go to Options > Interaction. In the Ethernet Control section, make sure the system is configured to get its IP Address Automatically.)

6. To select a mix, tap its tile. The Mix screen appears for the selected Aux (or Mains).

Personal Monitoring

Audio Distribution



Audio Distribution

You can easily connect your personal monitoring solution of choice to S6L, using any available analog, AES, TOSLINK, MADI, or Dante™ outputs.

Integrating S6L's 96k native digital audio with external 48k gear is easy. You can use the built-in MADI Out on each Stage 64 (configure it for 48k). Keep in mind that the built-in MADI Out on Stage 64 provides 1-to-1 splits of inputs only (no stems or sub-mixing).

S6L's flexible patching makes it easy to send any channel or combination of channels (including Auxes, Group outs, and custom Matrix mixes) to any available output. Patching can be stored and recalled via Snapshots, with extensive control of Aux Sends and nearly all other system parameters.

For more information on available personal monitoring solutions and how to choose the best one for you, consult your Avid Authorized Reseller.



Resources: Support and Customer Care

To contact Avid support and for information about Support Plans visit:

[Contact Audio & Music Support](#)

For information and links for downloads, activation and registration, Knowledge Base, resources (documentation, data sheets, brochures, and similar), training, community resources, repairs and warranty, and video resources, visit:

[VENUE | S6L Systems Learn & Support](#)

VENUE Live Sound Hotline

If you need emergency support, call us.

Please have your System ID ready when you call.

Americas	Europe	Asia
US: +1 978-275-2557 LATAM: +1 954-746-0956	Europe: +44 1753 659 500	Korea: +82 2 782 4215 China: +86 10 57306096 Japan: +81 3-3505-6138



Resources: Training and Documentation

Training and Curriculum

[Find a VENUE Training Course](#)

Webinars (Video Training and Interviews on Avid.com)

<http://www.avid.com/live-sound-webinars>

Live Sound Videos (More Live Sound Video Resources on Avid.com)

<http://www.avidblogs.com/live-sound-videos/>

YouTube

Discover the powerful and intuitive workflows of the Avid VENUE | S6L live sound system. Join veteran live sound engineer and Avid senior market specialist Robert Scovill as he and other VENUE Product Specialists take you through key control surface workflows on the VENUE | S6L live sound system in this in-depth video series.

[VENUE | S6L Workflows](#)

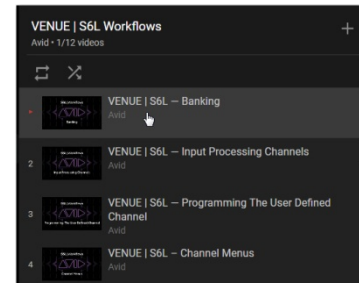

Documentation

You can download the latest editions of all user guides for S6L from your [Avid Account](#) and from the [S6L Documentation](#) site on our Knowledge Base. Here are descriptions of some of the most useful guides available there:

- *VENUE | S6L Installation Guide.pdf* provides complete hardware and software installation instructions, including how to activate and download VENUE software and how to perform a software System Restore and a Software Update.
- *Intro to S6L.pdf* is for first-time users of Avid VENUE | S6L systems. It introduces the main components of the system and gives you practical experience with inputs, signal routing, processing, and more. Along the way you'll find links to many of our videos on YouTube and the Avid web site that demonstrate each topic and provide additional information.
- *VENUE | S6L System Guide.pdf* provides complete operational information for using the system day-to-day, including patching and signal routing, snapshots, recording and playing back with Pro Tools, Show file management, Events, and more.
- *S6L Live Recording Guide.pdf* includes examples and step-by-step instructions for live recording, Virtual Soundcheck, integrated Pro Tools playback and more.
- Hardware-specific guides show how to install and integrate I/O expansion cards and options. Hardware guides include the *AVB-192 Network Card Installation.pdf*, *Stage 64 I/O Card Installation.pdf*, and guides for the HDX-192 DSP Expansion Card, MADI-192 MADI Option Card, DNT-192 Dante Option Card, WSG-HD Waves SoundGrid Option Card, and other options.
- Check the latest *What's New in VENUE.pdf* for information about each software release.

General

For information and links for downloads, activation and registration, Knowledge Base, resources (including documentation, data sheets, brochures, and similar), training, community resources, repairs and warranty, and video resources, visit:

[VENUE | S6L Systems Learn & Support](#)

Resources: Community and Social

Take advantage of the following resources to participate in the ever-growing S6L global community, and contribute to the development of current and future Avid products.

User Conferences ([Avid Pro Audio Community](#) for Pro Tools, [VENUE](#), and Other Avid Audio Products)

[VENUE Ideascale](#) (Make and Vote on Suggestions for New Features and Products)

Social



[Avid Live Sound blogs](#)



[Avid Live Sound FaceBook](#)



[Avid LiveSound Twitter](#)



Specifications: Weight

Weight

Control Surfaces

	S6L-32D	S6L-24D	S6L-24C
Weight	154.5 lbs (70 kg)	119 lbs (54 kg)	84 lbs (38 kg)

Engines

	E6L-192/144	E6L-112
Weight	74 lbs (33.5 kg)	71 lbs (32 kg)

Stage I/O Units

	Stage 64	Stage 32	Stage 16
Weight	Empty: 46 lbs (20.8 kg) Full: 69 lbs (31.2 kg)	Full: 49 lbs (22 kg)	21 lbs (9.5 kg)



Specifications: Power

S6L Control Surface

Power

S6L-24D and S6L-24C will use slightly less power than shown below for S6L-32D.



S6L-32D Power Measurements, 110V/60Hz

Parameter	Measurement	Units	Accuracy (\pm)	Notes
RMS Input Voltage	110	VAC	0.05% + 0.25V	
Frequency	60	Hz	0.1% \pm 1 digit	
RMS Input Current	2.425	A	0.1% + 0.15A	
Peak Input Current	61.188	A	0.2% + 0.5A	Internally limited by AC supply
Crest Factor	1.64		1.5%	
VA (Reactive) Power	267.8	VA	0.15% + 9 VA	
Real Power	257.8	W	0.15% + 9 W	
Power Factor	0.97		0.03	
Current THD	20.65	%A		EN61000-3-2 Class A compliant



S6L-32D Power Measurements, 220V/50Hz

Parameter	Measurement	Units	Accuracy (\pm)	Notes
RMS Input Voltage	220	VAC	0.05% + 0.25V	
Frequency	50	Hz	0.1% \pm 1 digit	
RMS Input Current	1.317	A	0.1% + 0.15A	
Peak Input Current	61.188	A	0.2% + 0.5A	Internally limited by AC supply
Crest Factor	1.68		1.5%	
VA (Reactive) Power	288.8	VA	0.15% + 9 VA	
Real Power	261.6	W	0.15% + 9 W	
Power Factor	0.91		0.03	
Current THD	16.65	%A		EN61000-3-2 Class A compliant

Specifications: Power

E6L Engine

Power

E6L Engine Configuration: E6L-192, with 1x AVB-192 Network Card and 1x HDX DSP Card.

Add 0.3 A for each HDX-192 DSP Card.



E6L-192 Engine Power Measurements, 110V/60Hz

Parameter	Measurement	Units	Accuracy (\pm)	Notes
RMS Input Voltage	110	VAC	0.05% + 0.25V	
Frequency	60	Hz	0.1% \pm 1 digit	
RMS Input Current	2.157	A	0.1% + 0.15A	
Peak Input Current	52.023	A	0.2% + 0.5A	Internally limited by AC supply
Crest Factor	1.66		1.5%	
VA (Reactive) Power	237.3	VA	0.15% + 9 VA	
Real Power	226.7	W	0.15% + 9 W	
Power Factor	0.96		0.03	
Current THD	18.77	%A		
RMS Input Voltage	110	VAC	0.05% + 0.25V	



E6L-192 Engine Power Measurements, 220V/50Hz

Parameter	Measurement	Units	Accuracy (\pm)	Notes
RMS Input Voltage	220	VAC	0.05% + 0.25V	
Frequency	50	Hz	0.1% \pm 1 digit	
RMS Input Current	1.261	A	0.1% + 0.15A	
Peak Input Current	55.999	A	0.2% + 0.5A	Internally limited by AC supply
Crest Factor	1.54		1.5%	
VA (Reactive) Power	277.6	VA	0.15% + 9 VA	
Real Power	228.5	W	0.15% + 9 W	
Power Factor	0.82		0.03	
Current THD	18.88	%A		

Specifications: Power

Stage 64/Stage 32

Power

Stage 64 Configuration: 6x SRI Analog Input Cards, x1 DSI Digital Input Card, 3x SRO Analog Output Cards, 1x DSO Digital Output Card. Actual power consumption can vary depending on the number and type of cards installed. ○ ○ ○ ●

Stage 32 power consumption will be less than Stage 64.

Stage 64 I/O Rack Power Measurements, 110V/60Hz

Parameter	Measurement	Units	Accuracy (±)	Notes
RMS Input Voltage	110	VAC	0.05% + 0.25V	
Frequency	60	Hz	0.1% ± 1 digit	
RMS Input Current	1.829	A	0.1% + 0.15A	
Peak Input Current	52.023	A	0.2% + 0.5A	Internally limited by AC supply
Crest Factor	1.59		1.5%	
VA (Reactive) Power	201.0	VA	0.15% + 9 VA	
Real Power	197.0	W	0.15% + 9 W	
Power Factor	0.98		0.03	
Current THD	18.73	%		EN61000-3-2 Class B compliant



Stage 64 I/O Rack Power Measurements, 220V/50Hz

Parameter	Measurement	Units	Accuracy (±)	Notes
RMS Input Voltage	220	VAC	0.05% + 0.25V	
Frequency	50	Hz	0.1% ± 1 digit	
RMS Input Current	0.928	A	0.1% + 0.15A	
Peak Input Current	52.023	A	0.2% + 0.5A	Internally limited by AC supply
Crest Factor	1.58		1.5%	
VA (Reactive) Power	204.0	VA	0.15% + 9 VA	
Real Power	195.4	W	0.15% + 9 W	
Power Factor	0.96		0.03	
Current THD	21.22	%		EN61000-3-2 Class B compliant

Specifications: Power

Stage 16

Power

Stage 16 measurements taken using 0dBFS level on all analog output channels.

Phantom power load of 4mA placed on 13 of 16 input channels.



Stage 16 I/O Rack Power Measurements, 110V/60Hz

Parameter	Measurement	Units	Accuracy (\pm)	Notes
RMS Input Voltage	110	VAC	0.05% + 0.25V	
Frequency	60	Hz	0.1% \pm 1 digit	
RMS Input Current	0.37	A	0.1% + 0.15A	
Peak Input Current	50.0	A	0.2% + 0.5A	Internally limited by AC supply
VA (Reactive) Power	44.0	VA	0.15% + 9 VA	
Real Power	43	W	0.15% + 9 W	
Power Factor	0.96		0.03	



Dimensions: S6L-32D

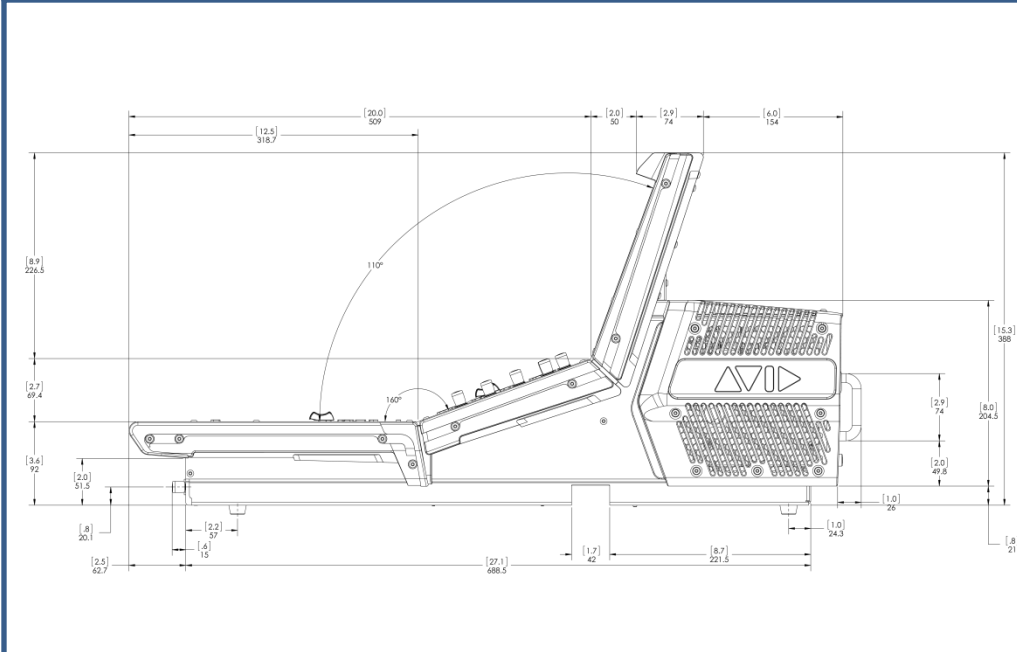
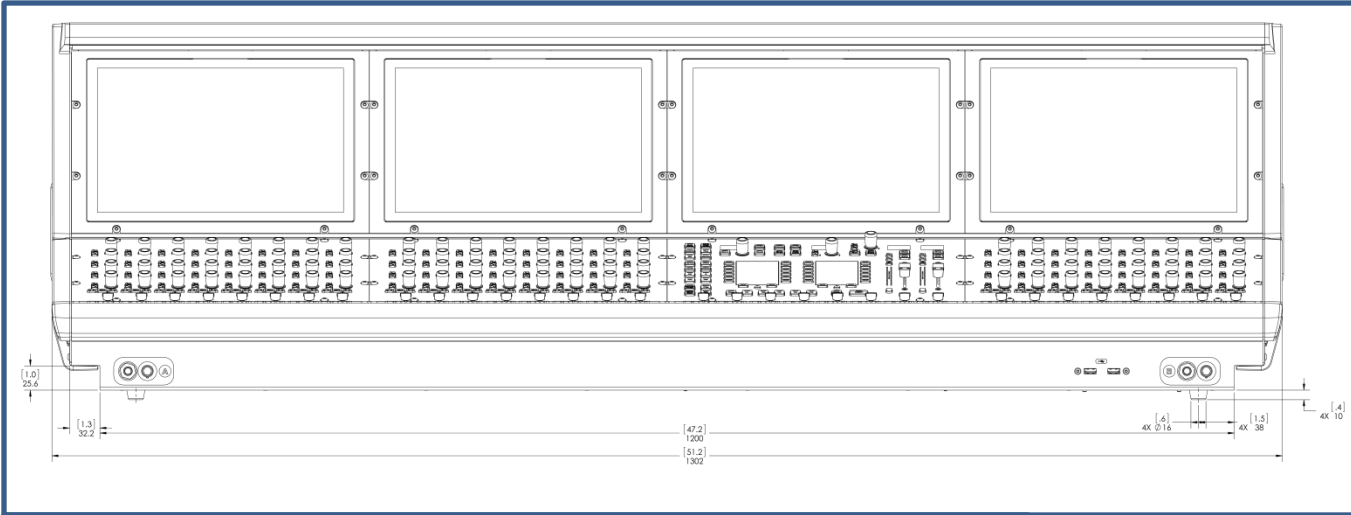

[DXF Line Drawings](#)

Parameter	Specification
Maximum Height, Front	3.6 inches (92 mm)
Maximum Height, Back	15.3 inches (388 mm)
Maximum Width	51.2 inches (1302 mm)
Maximum Depth	30.9 inches (786.5 mm)

Dimensions: S6L-24D/24

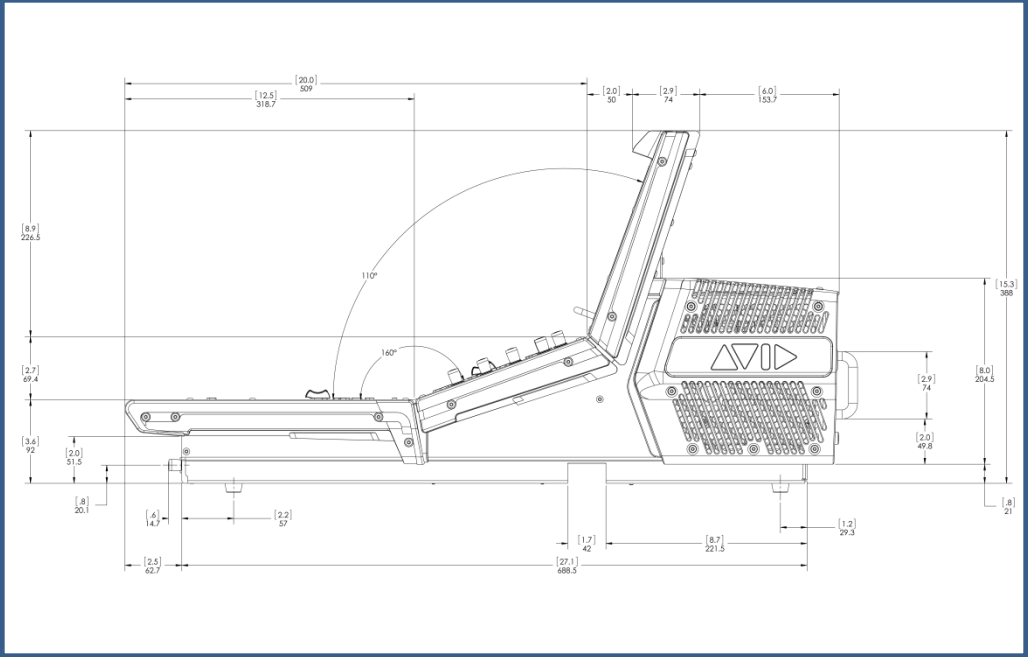
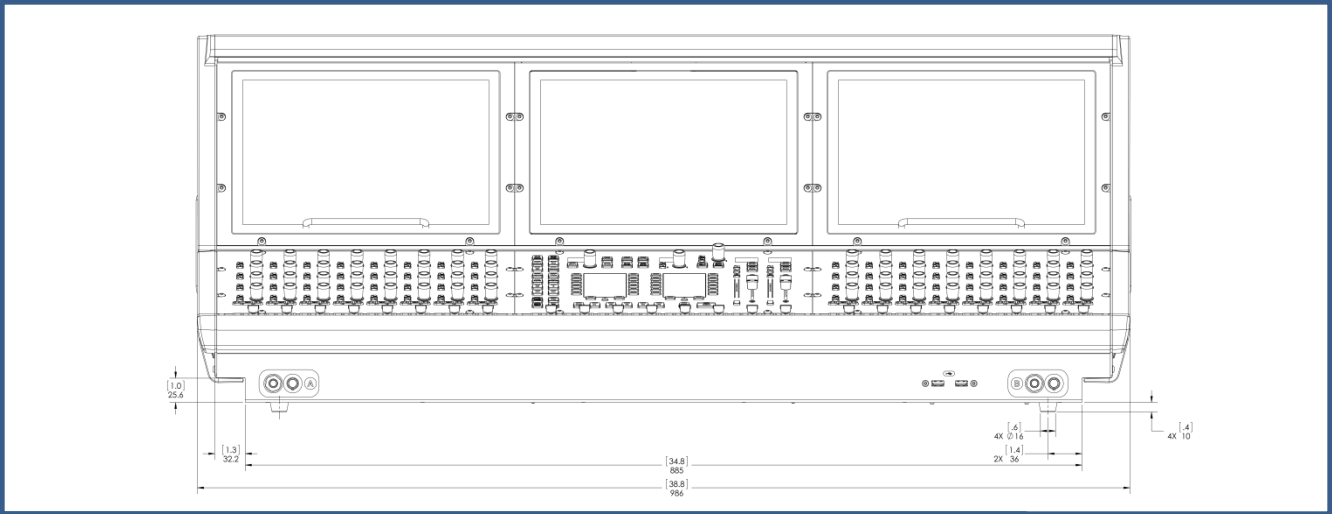

[DXF Line Drawings](#)

Parameter	Specification
Maximum Height, Front	3.6 inches (92 mm)
Maximum Height, Back	15.3 inches (388 mm)
Maximum Width	38.8 inches (986 mm)
Maximum Depth	30.9 inches (786.5 mm)

Dimensions: S6L-24C

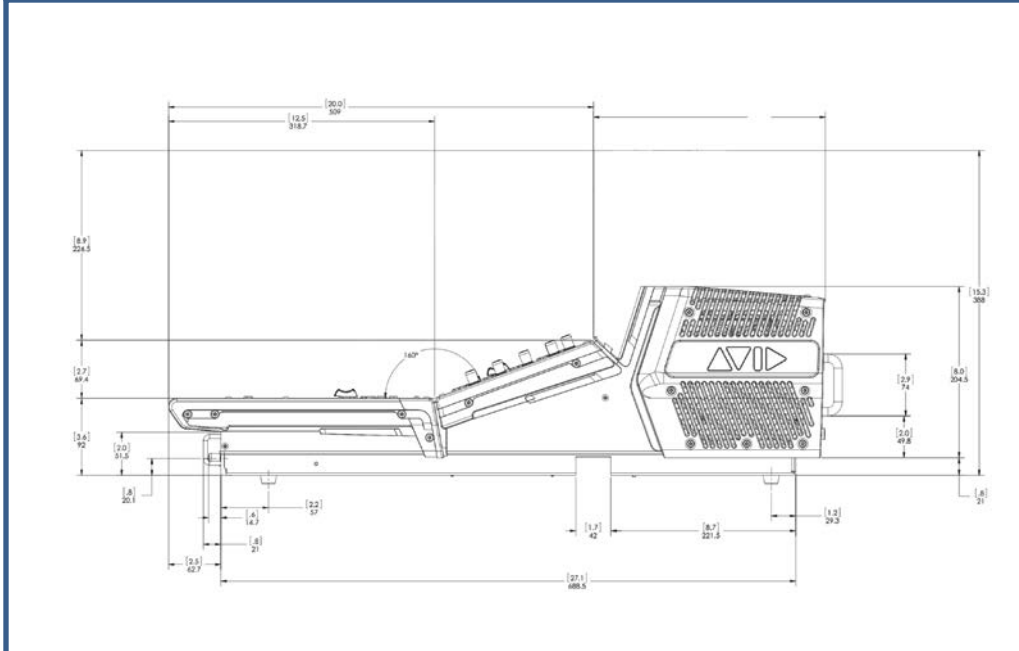
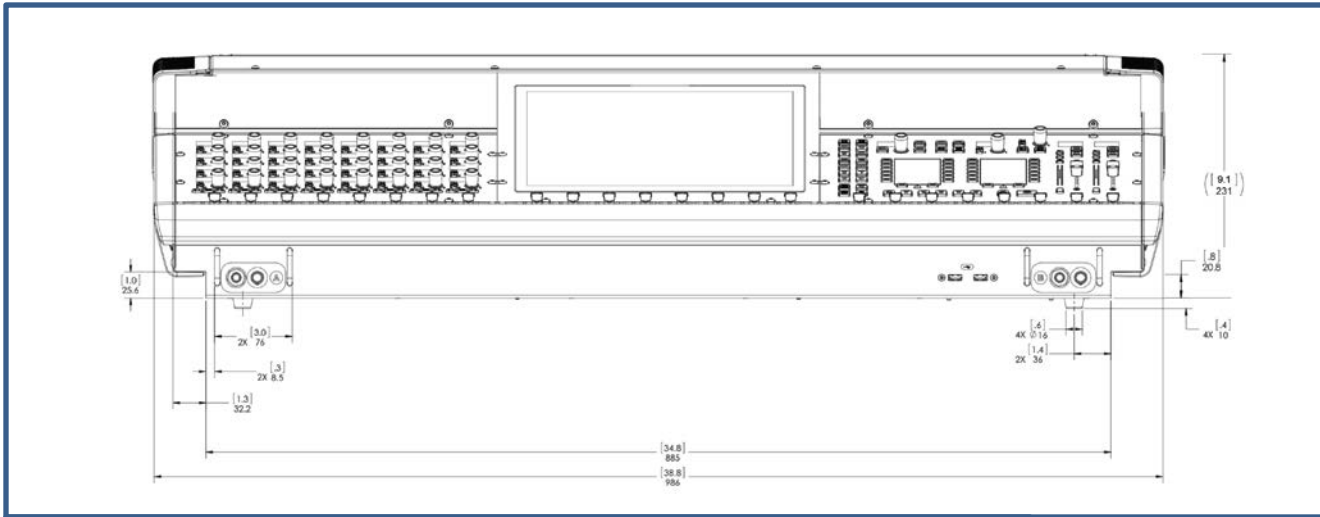

[DXF Line Drawings](#)

Parameter	Specification
Maximum Height, Front	3.6 inches (92 mm)
Maximum Height, Back	8 inches (205mm)
Maximum Width	38.8 inches (986 mm)
Maximum Depth	30.9 inches (786.5 mm)

Dimensions: E6L Engine

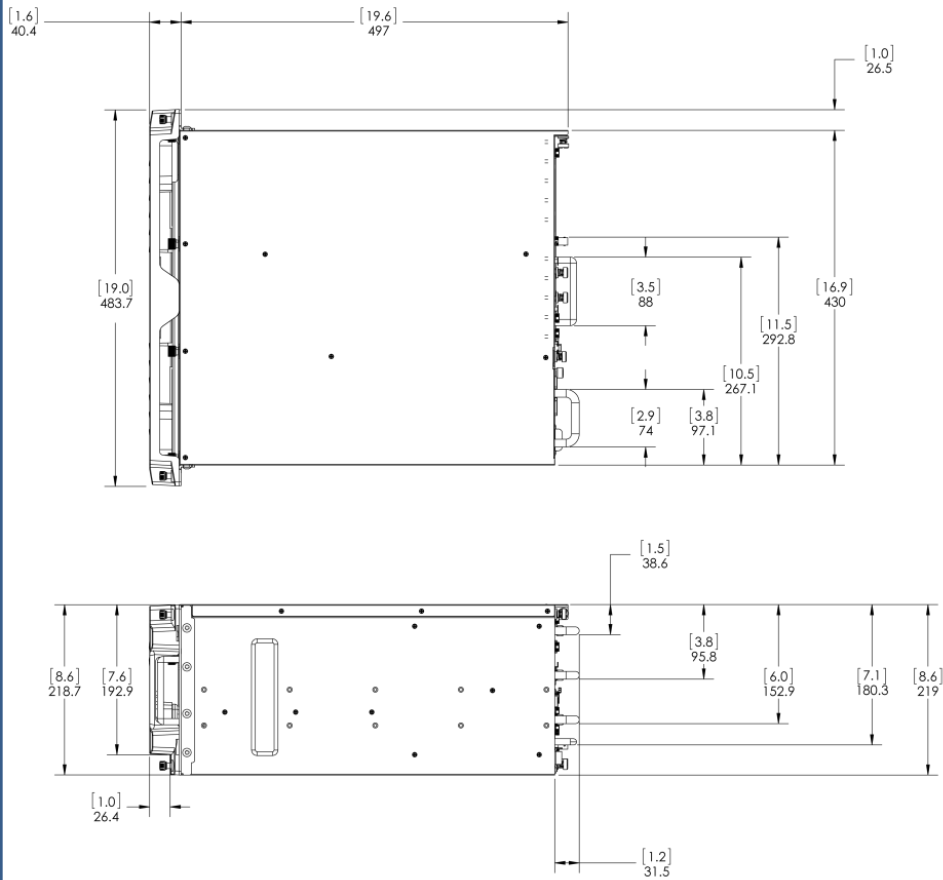

[DXF Line Drawings](#)

Parameter	Specification
Maximum Height	8.6 inches (218.7 mm)
Rack Spaces	5U
Maximum Width	19 inches (483 mm)
Depth with Bezel	21.2 inches (537 mm)
Depth without Bezel	19.6 inches (497 mm)

Dimensions: Stage 64

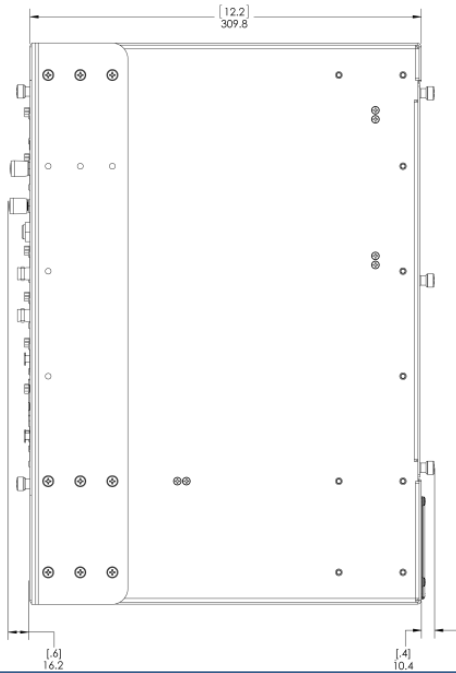
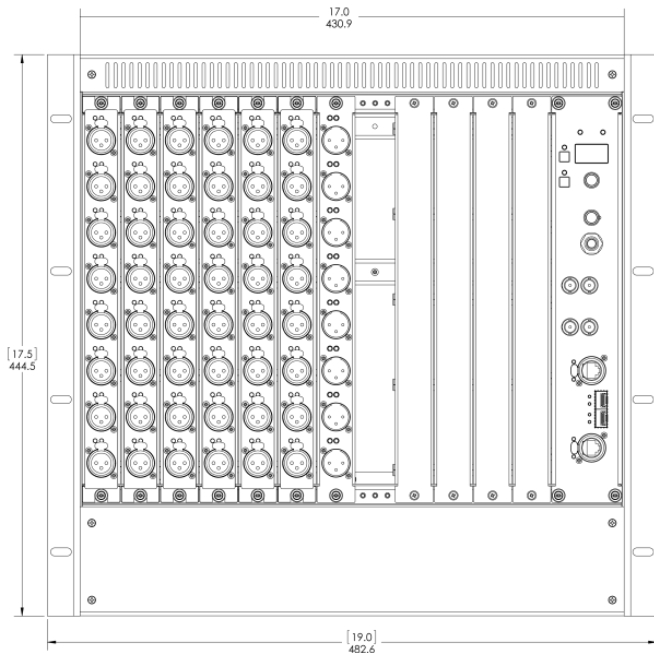

[DXF Line Drawings](#)

Parameter	Specification
Maximum Height	17.5 in (444.5 mm)
Rack Spaces	10U
Width with Rack Ears Width without Rack Ears	19 inches (483 mm) 17 inches (430.9 mm)
Maximum Depth	12.2 in (309.8 mm)

Dimensions: Stage 32

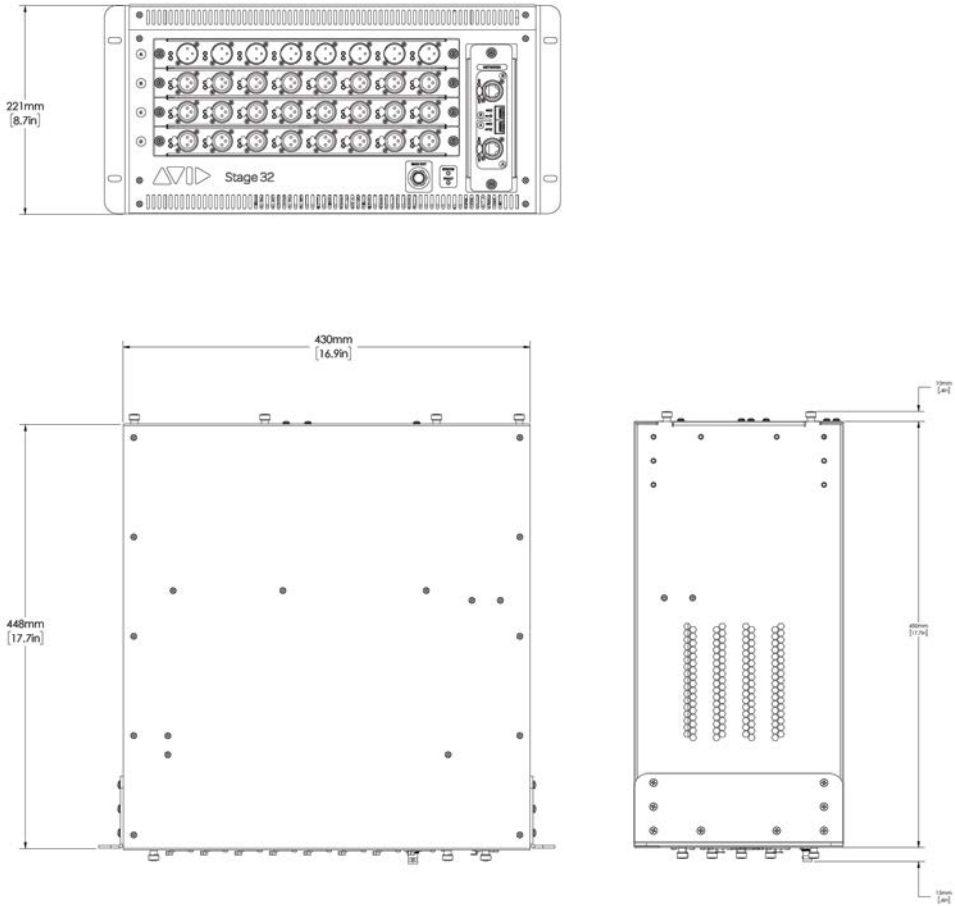

[DXF Line Drawings](#)

Parameter	Specification
Maximum Height	17.5 in (444.5 mm)
Rack Spaces	5U
Width with Rack Ears Width without Rack Ears	19 inches (483 mm) 17 inches (430.9 mm)
Maximum Depth	12.2 in (309.8 mm)

Dimensions: Stage 16

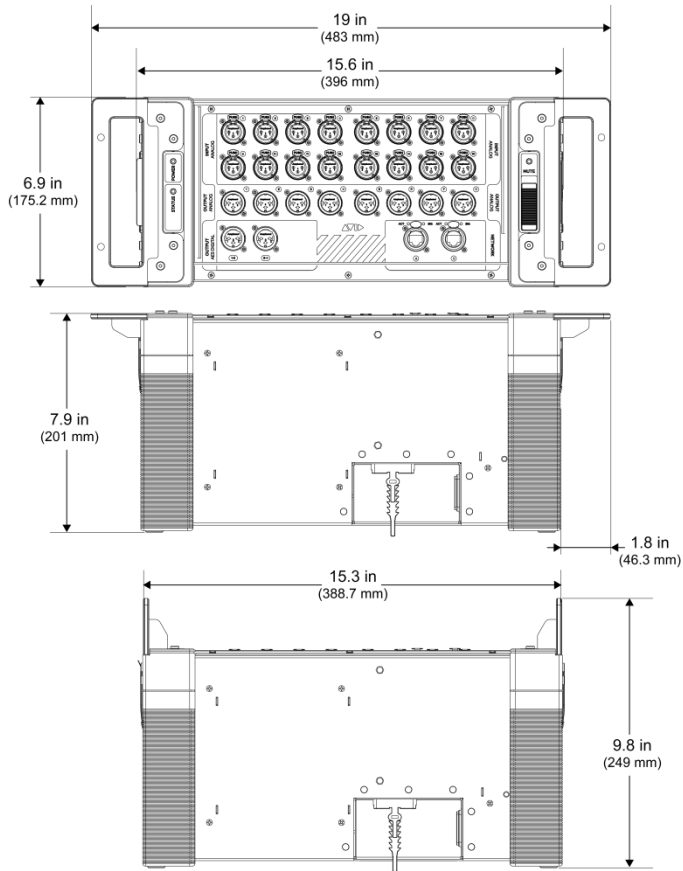

[DXF Line Drawings](#)

Parameter	Specification
Maximum Height	6.9 in (175.2 mm)
Rack Spaces	4U
Width (with Rack Ears)	19 inches (483 mm)
Width (Rack Ears configured as handles)	15.6 inches (396 mm)
Depth (with Rack Ears)	7.9 in (201 mm)
Depth (Rack Ears configured as handles)	9.8 in (249 mm)

Cabling Requirements

Power Connections

- Power connections on all S6L system devices are auto voltage-selecting (100 to 240V nominal, 90-260V maximal, 50–60 Hz).
- Make sure your power source is correctly rated for the number of units you are connecting. A surge-protected power source (not included) is highly recommended.

Audio Network Connections

- A minimum of four (4) shielded Cat 5e (350 MHz) or better Ethernet cables are required for software installation and operation of a base configuration. One Ethernet cable is included with the S6L control surface, the other three (or more depending on the number of devices in the configuration) must be purchased separately.
- Audio network connections between S6L system components can be made using either copper or fiber-optic audio network cables. Cable types can be mixed within a system, but only one type of connection (copper or fiber) should be used per audio network port. Each *Network port* (A or B) has two *connectors* (one copper, and one fiber). Never have both copper and fiber connected to the same network port simultaneously.

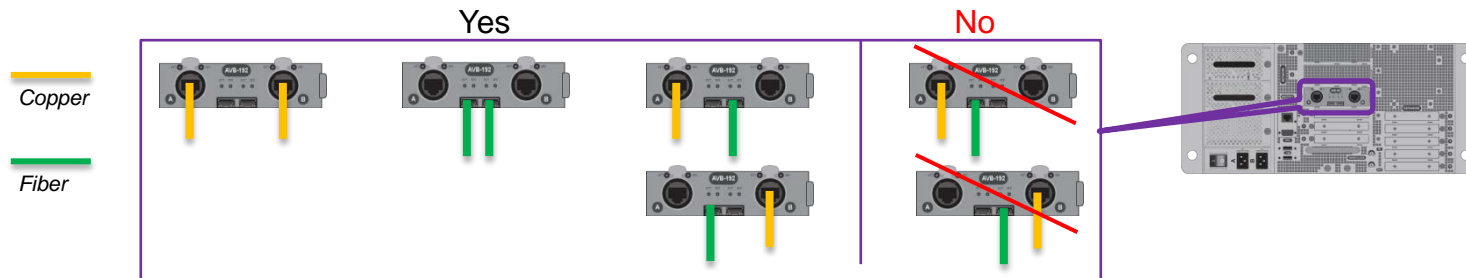

Copper

- Shielded Cat 5e (350 MHz) or better Ethernet cable with Neutrik etherCON connectors required. Supports up to 100 meters per connection.

Fiber-Optic

- S6L systems support single-mode fiber (SMF) or multi-mode fiber (MMF) cable to make audio network connections between components, as follows:
 - **SMF** Requires single-mode 9/125 OS1 or OS2 cables with duplex LC connectors and two qualified single-mode SFP transceivers per connection, supporting distances of up to 10 kilometers.
 - **MMF** Requires multi-mode 50/125 OM2 or better cables with duplex LC connectors and two qualified multi-mode SFP transceiver modules per connection, supporting distances of up to 500 meters.

Pro Tools and VENUeLink Connections

- Shielded Cat 5e (350 MHz) or better Ethernet cable with RJ-45 connectors is required for AVB audio connections for Pro Tools and/or VENUeLink.

ECx Ethernet Control Connections

- Standard Cat 5e Ethernet cable required.

For the most up-to-date list of requirements and supported cables, bookmark this article on our Knowledge Base: [Avid-S6L-Support](#)

Other VENUE Systems

Follow these links for information about S3L-X/S3L systems, and legacy VENUE systems.

[S3L-X](#)

Follow this link for [Legacy Systems and Other Products](#) then choose Filter by category > Live Sound.

