

Winch 50 & Winch 50 Double Item No 245 & 246.701

User Manual

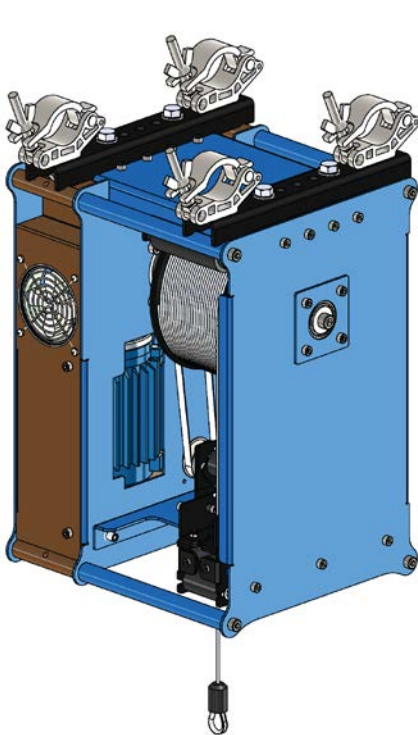

Winch 50 (245)

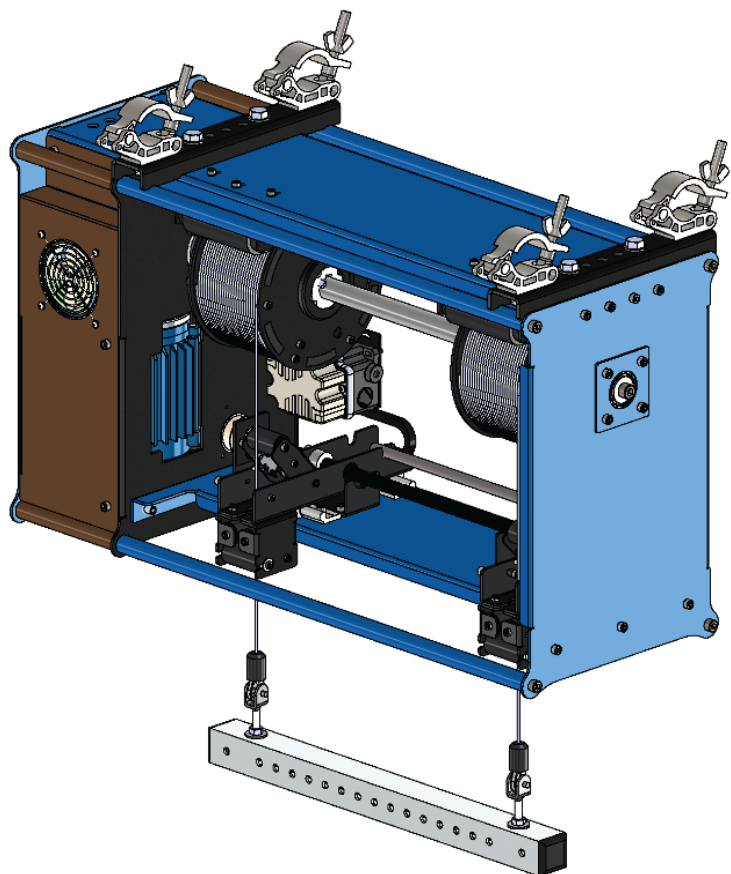

Winch 50 Double (246)

Safety Information



WARNING!

Read the safety precautions in this section before installing, powering, operating or servicing this product.

The following symbols are used to identify important safety information on the product and in this manual:



DANGER!
Safety hazard.
Risk of severe injury or death.



DANGER!
Hazardous voltage. Risk of lethal or severe electric shock.



WARNING!
Fire hazard.



WARNING!
Burn hazard. Hot surface. Do not touch.



WARNING! Refer to user manual.



This product is for professional use only. It is not for household use. This product presents risks for severe injury or death due to fire hazards, electric shock, and falls.



Read this manual before installing, powering or servicing the winch; follow the safety precautions listed below and observe all warnings in this manual and printed on the winch. If you have questions about how to operate the winch safely, please contact you Wahlberg Motion Design supplier or Wahlberg Motion Design.



PROTECTION FROM ELECTRIC SHOCK

- Disconnect the winch from AC power before removing or installing any cover or part and not when in use.
- Always ground (earth) the winch electrically.
- Use only a source of AC power that complies with local building and electrical codes and has both overload and ground-fault (earth-fault) protection.
- Before using the winch, check that all power distribution equipment and cables are in perfect condition and rated for the current requirements of all connected devices.
- Power input throughput cables must be rated 20 A minimum, have three conductors 1.5 mm² (AWG16) minimum conductor size and an outer cable diameter of 5-15 mm (0.2-0.6 inch). Cables must be hard usage type (SJT or equivalent) and heat-resistant to 90°C (194°F) minimum. In the EU the cables must be <HAR> approved or equivalent.
- Use only Neutrik powerCON TRUE1 NAC3FX-W cable connectors to connect to power input sockets. Use only Neutrik powerCON TRUE1 NAC3FX-W cable connectors to connect to power throughput sockets.
- Assembly power supply cables following the instructions in this manual only (see page 15).

- Isolate the winch from power immediately if the power plug or any seal, cover, cable, or other component is damaged, defective, deformed, wet, or showing signs of overheating. Do not reapply power until repairs have been completed
- Do not expose the winch to rain or moisture.
- Refer any service operation not described in this manual to a qualified technician.

PROTECTION FROM BURNS AND FIRE

- Do not operate the winch if the ambient temperature exceeds 40° C (104° F).
- The exterior of the winch becomes warm during use. Avoid contact by persons and materials. Allow the winch to cool for at least 10 minutes before handling.
- Do not modify the winch in any way not described in this manual.
- Install only genuine Wahlberg parts.

PROTECTION FROM INJURY

- Fasten the winch securely to a fixed surface, rig, or structure when in use. The winch is not portable when installed.
- Ensure that any supporting structure and/or hardware can hold at least 10 times the weight of all the devices they support
- If suspending from a rigging structure, fasten the winch using the supplied 4x Manfrotto slim coupler according to the manual, see page 11.
- Always install the winch as described in this manual. If the winch is installed in a location where it may cause injury or damage if it falls, install as described in 11.
- If possible, allow enough clearance beneath the winch so it cannot cause any danger to personnel beneath it. Alternatively, adjust the lower limit accordingly following the instructions in this manual.
- Check that all external cobbles and rigging hardware are securely fastened.
- Block access below the work area and from a stable platform whenever installing, servicing or moving the winch.
- Do not operate the winch with missing or damaged covers, shields, or wire.
- Do not use the winch over the head of people
- Do not use the winch to lift people or animals.
- Only use the winch to lift static loads.

Intact wire



Broken wire



Before each use

- Check that the winch is safely and correctly installed/mounted.
- Inspect the entire length of the wire rope for bends, damage and wear, cut cords, corrosion and abuse.
- Inspect the wire ferrule crimp and thimble for damage, wear, corrosion or abuse.
- Check the load is safely mounted and weighs max. 50 kg (110.2 lb).
- Check safety functions (limit switches, slack detection, emergency stop)
- Check that the wire is wound neatly on the drum

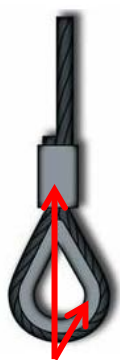

Inspection points

Warning! Do not use the winch if any damage or error is found!



Disposing of this product

Wahlberg Motion Design products are supplied in compliance with Directive 2002/96/EC of the European Parliament and of the Council of the European Union on WEEE (Waste Electrical and Electronic Equipment), as amended by Directive 2003/108/EC, where applicable.

Help preserve the environment! Ensure that this product is recycled at the end of its life. Your supplier can give details of local arrangements for the disposal of Wahlberg Motion Design products.

Index

SAFETY INFORMATION	2
INDEX	3
TECHNICAL SPECIFICATIONS	6
DRAWING	7
INTRODUCTION	9
PACKAGE CONTENT	9
DESCRIPTION.....	9
SAFETY FUNCTIONS	10
AREA OF USE.....	10
USING FOR THE FIRST TIME	10
TRANSPORT	11
PHYSICAL INSTALLATION	12
FASTENING THE WINCH TO A FLAT SURFACE	12
MOUNTING THE WINCH ON A TRUSS	12
MOUNTING THE LOAD	13
AC POWER	14
POWER CABLES AND POWER PLUG	14
INSTALLING A POWER INPUT CONNECTOR ON A POWER CABLE	15
DATA LINK	16
TIPS FOR RELIABLE DATA TRANSMISSION	16
CONNECTING THE DATA LINK	16
EMERGENCY STOP SWITCH (OPTIONAL)	17
ENABLE EMERGENCY STOP	18
READY TO USE	18
SET UP	20
COUNTERBALANCE	20
MENU SETTING	20
MENU STRUCTURE.....	21
ADJUSTABLE PARAMETERS.....	24
DETAILED EXPLANATION OF PARAMETERS	25
DMX ADDRESS SETTING	25
DMX CHANNEL OVERVIEW	26
ADJUSTING HARD LIMIT SWITCHES	27
NORMAL OPERATION	29
SYNCHRONIZED MOVEMENTS OF MULTIPLE WINCHES.....	30
LED FUNCTIONS	31
ERROR AND ERROR CODES:	31
SERVICE AND MAINTENANCE	34
PARTS	34
ON-SITE SERVICE.....	34
MAINTENANCE PLAN.....	35
CHECKLIST	35
LIFE OF THE WIRE	36
WIRE DISCARD CRITERIA	37
APPENDIX 1	38
APPENDIX 2	39
APPENDIX 3	40
APPENDIX 4	42
WINCH 50 - CHEAT SHEET	44

Technical specifications

Model:	Winch 50 & Winch 50 Double
Item no.:	245 and 246.701
Dimensions (L×W×H):	
245	345 × 298 × 445 mm / 13.6 × 11.7 × 17.5 in.
246.701	797 × 298 × 445 mm / 31.4 × 11.7 × 17.5 in.
Power supply:	200-240V AC 50-60 Hz.
Power consumption:	500 Watt.
Power inlet/outlet:	Neutrik powerCON TRUE1 NAC3PX (F/M)
DMX control signal:	DMX 512 1990 + DMX512A / 6 channels used.
DMX connection:	5 pole XLR, male & female
Lifting height:	12.5 m (41.0 ft.)
Lifting capacity:	50 kg (110 lb)
Lifting speed:	Variable, 0.09-0.45 m/s (3.5-17.7 in/s)
Minimum load:	5 kg (11 lb)
Noise emission (at 1 m):	~50 dB
Ambient temperature	0-40°C (32-104°F)
Own weight:	
245	29.1 kg (64.2 lb)
246.701	45 kg (88.2 lb)
Mounting clamp:	2×2 Slim eye coupler 50 mm (2 in)
Motor:	230V AC, 0.55 kW 2800 rpm
Duty cycle:	Maximum 30% at max. load (refer to page 29) Minimum 23 min OFF after 10 minutes ON
Lifting wire specifications:	
Lifting wire:	3 mm (1/8 in) 19×7 galvanised steel wire (EN 12385-4)
Minimum breaking load (wire):	588 kg (5.79 kN / 1,296 lb)
Wire safety factor:	Minimum 10
Wire fleet:	83 mm (3.27 in)
Wire fleet angle:	None

Drawing

Winch 50 (245)

More detailed drawings and from more angles can be found in Appendix 1 on page 38.

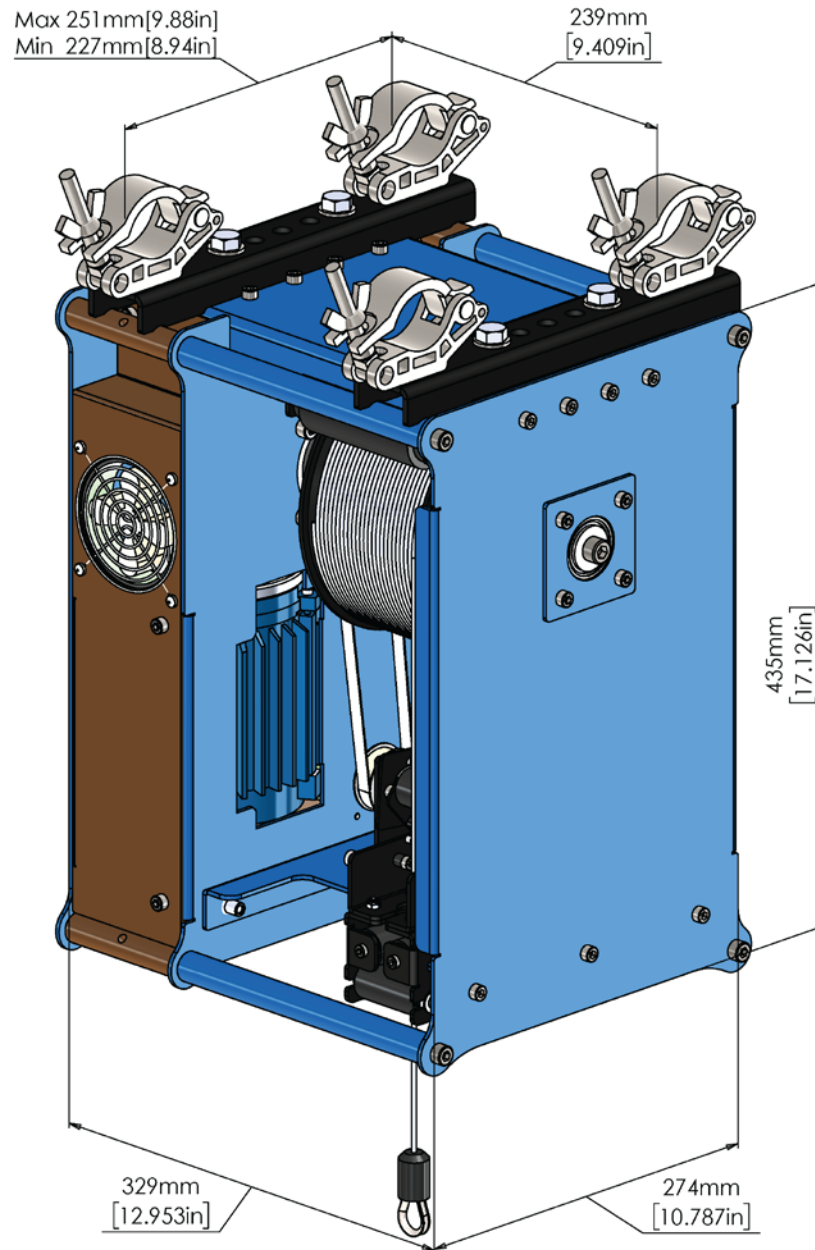

Winch 50 Double (246.701)

More detailed drawings and from more angles can be found in Appendix 2 on page 39.

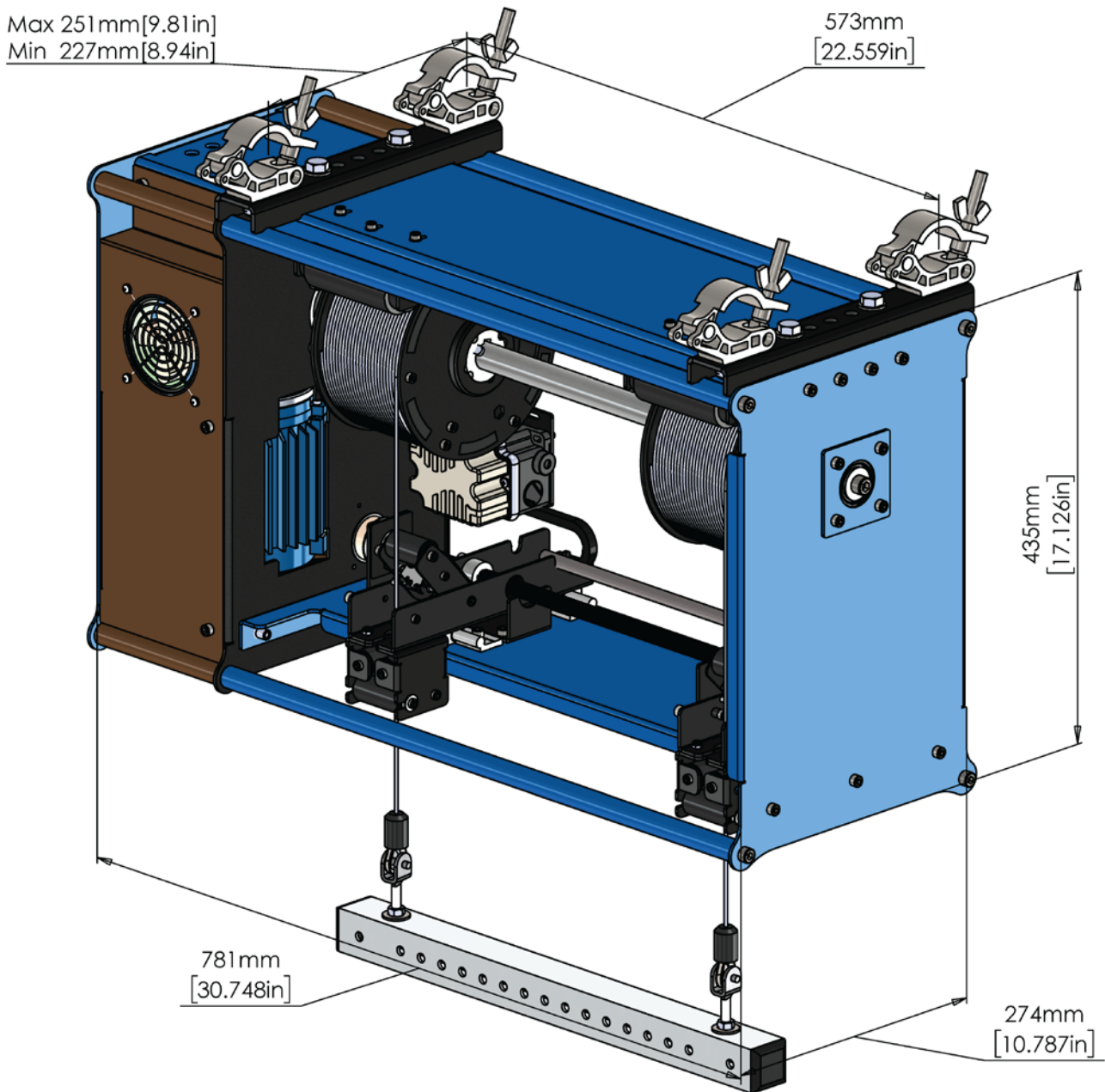

Introduction

Thank you for selecting the Winch 50, a DMX controlled winch from Wahlberg Motion Design. Before using the winch for the first time, please read this manual carefully. Failure in handling can cause injury of persons and/or damage the winch.

Package content

- 1 × Winch 50 (245) or Winch 50 Double (246.701)
- 1 × PowerCON NAC3FX-W female plug for power cable
- 1 × Instruction manual
- 1 × Cheat Sheet

Description

Winch 50 is a wire winch for stage use, mainly for use in theatres, shows and concerts. It lifts props and small set pieces in and out of the stage sphere at a maximum load of 50 kg up and down. The lifting height is 12.5 m. The lifting speed is between 9 cm/s and 45 cm/s.

The winch is controlled by the standard DMX controlling signal, so a normal lighting desk can be used to control the movement, programmed as normal light. For a low number of winches, a standard lighting desk can be used, but when many winches are used, more advanced desks should be used to maintain easy control of the units.

The Winch 50 uses 6 channels of the DMX-line, and they control the position, speed, limits, and reset functions.

The Winch 50 has an advanced internal positioning system with 16 bit, used for finding the position desired by the operator. With a 16 bit positioning channel (ch1 and ch2) the operator set the desired position, and the winch will run to this position, with the speed applied on the speed channel (ch3).

Channel 4 is used to enable power.

With channel 5 and 6 it is possible to set the soft TOP and BOTTOM limits of the movement of the winch, adjusting its span of motion. Channel 5 is likewise used for resetting the winch, when powering up.

On the winch it is possible to adjust the hard TOP and BOTTOM limits and in that way set the absolute span of motion.

Multiple winches are easily daisy chained with power in-out and DMX in-Out, allowing to create advanced and dynamic movements with 100's of winches working together in the same installation.

Safety functions

The control system ensures that the motor only is powered when:

- The control signal is reliable.
- The position and speed control is on.
- The motor position is calculated after which a PID regulator calculates the motor speed and distance.
- No overload.

Winch 50 should only be operated by an experienced DMX-controlled-lighting-desk-operator. The lighting desk has to be programmed according to the manual, so the winch will stop when the speed is put to 0 %. It is also possible for the user to stop the winch by disconnecting it from the main. After power failure the start position of the winch needs to be reset before the winch can function again.

Manual operation of the winch is only intended for mounting, service, and tests.

Area of use

The Winch is intended for indoor use only. It is designed for lifting and lowering material at the weight and speed stated in "Technical specifications" in page 6. Any other use of the winch may result in a risk of injury of persons or equipment damage. Exceeding the load rating may cause failure of the equipment.

Use only approved rigging connectors to secure the load to the wire and do not wrap the wire around the load as this will damage the wire and result in a risk of injury of persons or equipment damage.

Do not modify the winch. For any modification of your winch, contact Wahlberg.

It is the customer's sole responsibility to comply with any relevant local laws, regulatory requirements, and restrictions, concerning the use of the winch.

For indoor use only!

Caution! To reduce the risk of electric shock or injury: use indoors only

Caution! To reduce the risk of electric shock, do not expose to rain: store indoors!



Using for the first time

Important! The Winch 50 must be protected from environmental factors such as physical shocks and vibration during transportation and storage.

Warning! Read "Safety Information" on page 2 before installing, powering, operating, or servicing the winch. Before applying power to the winch:

- Check the Wahlberg Motion Design website at www.wahlberg.dk for the most recent documentation and technical information about the winch 50. Wahlberg user manual revisions are identified by the revision number in the bottom of each page.
- Carefully review the "Safety Instructions" on page 2.
- Check that the local AC mains power source is within the winch power voltage and frequency ranges.
- See "Power cables and power plug" on page 2. Install a Neutrik powerCON TRUE1 NAC3FX-W power input connector on a suitable power cable. If using the power from a mains power outlet, install a suitable power plug on the power cable.



Transport



Important! The Winch 25 must be protected from environmental factors such as physical shocks and vibration during transportation.

Before transport, it is important to roll the wire of the winch up until the hard TOP limit, so a maximum of 10 cm (3.9 inch) remains out of the winch. Fix the wire with a cable tie or an elastic cord. If the wire is loose it may jump off the wire wheel during transport and cause damage to the winch.

Use only the original packaging, flight case, or pallet frame for protecting the winch during transport. Contact Wahlberg for enquiries regarding flight cases or pallet frames.

Physical installation



Warning! The Winch 50 must be either fastened to a flat surface such as a roof, or clamped to a truss or similar structure in such a way that the wire exit points downwards. Do not apply power to the Winch 50 if it is not securely fastened.

Warning! The supporting surface must be hard and flat. Fasten the winch securely.

Warning! Use only the supplied rigging clamps.

Fastening the winch to a flat surface

The Winch 50 can be fastened to flat surface such as a roof. Check that the surface can support at least 10 times the weight of all winches and equipment to be installed on it.

Mounting the winch on a truss

The Winch 50 can be clamped to a truss or similar rigging structure.

To clamp a Winch 50 to a truss:

1. Check that the rigging clamps are undamaged and that the rigging structure can support at least 10 times the combined weight of all winches and equipment to be installed on it.
2. Block access under the work area. Working from a stable platform, hang the winch on the truss with the wire downwards. Tighten the rigging clamp.
3. Use the supplied 4 slim couplers sitting on the top plate. It is important to use all 4 slim couplers for mounting because the load is not evenly distributed across the winch.

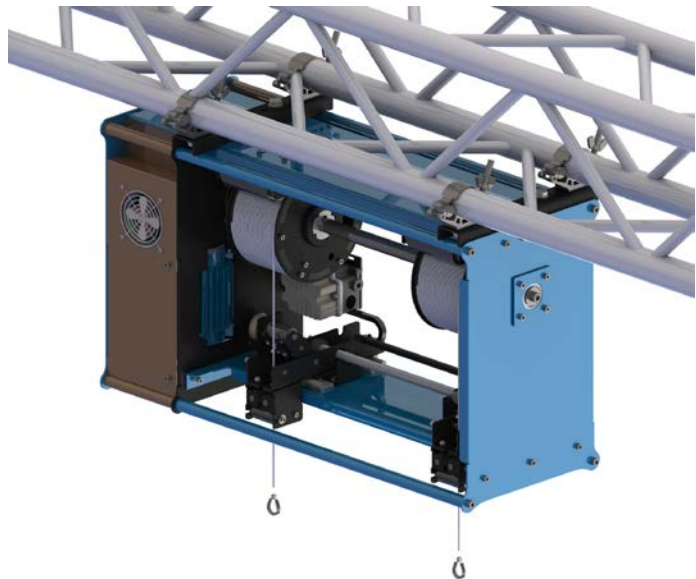

Mounting the load



Attention! The load must be mounted on the wire in a way to insure that the load never can run into the winch.

The load can be mounted using the supplied loading hook or any other hooks designed for lifting. Ensure that the loading hook has a minimum breaking load of at least 500 kg.

AC power

Warning! Read “Safety Information” on page 2 before connecting the Winch 50 to AC mains power.



Warning! For protection from electric shock, the Winch 50 must be grounded (earthed). The power distribution circuit must be equipped with a fuse or circuit breaker and ground-fault (earth-fault) protection.

Warning! Socket outlets or external power switches used to supply the Winch 50 with power must be located near the winch and easily accessible so that the winch can easily be disconnected from power.

Warning! Check that the voltage range specified on the winch’s serial number label matches the local AC mains power voltage before applying power to the winch. Do not apply AC mains power to the winch at any other voltage than that specified on the winch’s serial number label.

Power cables and power plug

The Winch 50 requires a power input cable with a Neutrik powerCON TRUE1 NAC3FX-W cable connector for AC mains power input. The cable must meet the requirements listed under “Protection from electric shock” on page 2.

Wahlberg Motion Design can supply the PowerCON input connector without a cable.

If you install a power plug on the power cable, install a grounding-type (earthed) plug that is rated 20 A. Follow the plug manufacturer’s instructions. The Neutrik assembly guide below shows standard wire color-coding schemes and some possible pin identification schemes; if pins are not clearly identified, or if you have any doubts about proper installation, consult a qualified electrician.

By supplying power to the winch, the display will show a start-up screen and then change to:



Installing a power input connector on a power cable

To install a Neutrik powerCON TRUE1 NAC3FX-W input connector on a power Cable, follow the original Neutrik instructions in Appendix 3 on page 40:

By supplying power to the winch, the display will show a start-up screen sequence showing the model number



Winch 50
WAHLBERG

Followed by a screen showing the software version, e.g. SW 503.003 as shown below

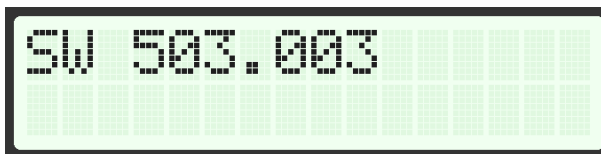

SW 503.003

Then a description of how to enter the menu

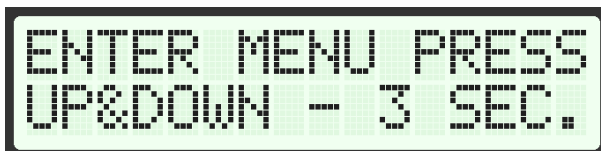

ENTER MENU PRESS
UP&DOWN - 3 SEC.

When it changes to the following, the winch is ready to be operated:



DMX CONTROL
START CHAN 1

Data link

A DMX 512 data link is required in order to control the winch via DMX. The Winch 50 has 5-pin XLR connectors for DMX data input and output. The pin-out on all connectors is pin 1 = shield, pin 2 = (-), and pin 3 = (+). Pins 4 and 5 in the 5-pin XLR connectors are not used in the Winch 50 but are available for possible additional data signals as required by the DMX512-A standard.

The Winch 50 is subject to the common limit of 32 devices per daisy-chained link. Note that if independent control of a winch is required, it must have its own DMX channels. Winches that are required to behave identically can share the same DMX channels. To add more winches or groups of winches when the above limit is reached, add a DMX universe and another daisy-chained link.

Tips for reliable data transmission

Use shielded twisted-pair cable designed for RS-485 devices: standard microphone cable cannot transmit control data reliably over long runs. AWG24 cable is suitable for runs up to 100 meters (328 ft.).

Never split a DMX line without using an opto-isolated RS-485 splitter/amplifier.

Terminate the link by installing a termination plug in the output socket of the last winch. The termination plug, which is a male XLR plug with a 120 Ohm, 0.25 Watt resistor soldered between pins 2 and 3, "soaks up" the control signal so it does not reflect and cause interference. If a splitter is used, terminate each branch of the link.

Connecting the data link

To connect the Winch 50 to data:

1. Connect the DMX data output from the DMX controller to the Winch 50's male 5-pin XLR DMX input connector (DMX 512 IN).
2. Connect the DMX output of the winch to the DMX input of the next winch and continue connecting winches output to input (DMX 512 OUT).
3. Terminate the last winch on the link with a 120 Ohm resistor.

The DMX lamp is the green led, above the display.

- Glows constantly, when the DMX connection is correct.
- Flashes if the DMX signal is missing or wrongly connected.

Emergency stop switch (Optional)



Warning! By default the emergency stop is NOT enabled!

The winch can be configured with an emergency stop; by default the emergency stop is not enabled.

The DMX control from a lighting desk should always have a set up so there is a button that sets the speed of the winch in operation to 0%. Normally lighting desks have a "blackout" button that sets all signals to 0% and this will also cause the winch to stop.

If the emergency stop switch is activated the red Error LED will be lit and the screen display shows: 'EMERGENCY STOP PRESSED':



The emergency stop switch is connected to the male 4 pole XLR connector on the winch. Pin 1 and Pin 4 should be powered with 12-15 volt DC to enable operation of the winch

Pin out:	Connection
Pin 1	GND
Pin 2	Not connected
Pin 3	Not connected
Pin 4	12-15 V DV



Enable Emergency stop

To enable emergency stop two steps are required.

Step 1: In 'MENU NAVIGATE' change 'E STOP' from OFF

Refer to section 'Menu setting' on the next page for guidance on how to navigate the menu.

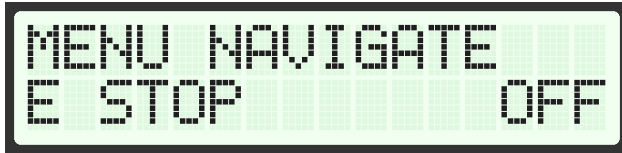

to ON

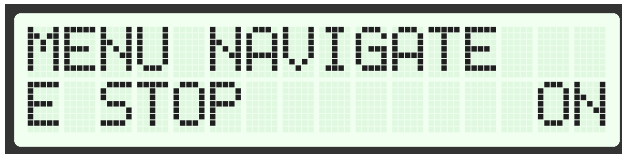

Step 2: Inside the unit there is an orange wire that needs to be set correctly for operation with/without emergency stop.

Emergency stop disabled

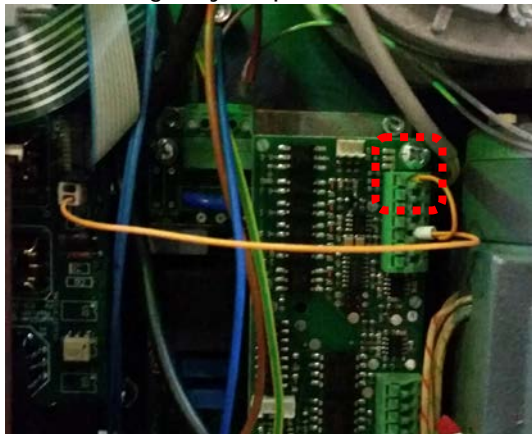

Emergency stop enabled



Orange wire loops pin 3 and 7

When the emergency stop is enabled and the little piece of orange wire is not connected, it is recommended that it is secured in some way so it does not touch anything. Some electrical tape will be enough to keep it in place.

Ready to use

When the emergency stop has been enabled both in the menu and in the winch, the Winch 50 connected to power, DMX, and an emergency stop switch, it is ready for use, and can be controlled from the lighting desk.

[This page is intentionally left blank]

Set up



Warning! Read "Safety Information" on page 2 before installing, powering, operating, or servicing the Winch 50.

Warning! Before running the winch, it is important to put a counterbalance on the wire. This is necessary, as the slack detection switch otherwise will be activated and will stop the winch.

Warning! Only experienced DMX users should operate the winch. Contact Wahlberg for further information and education on DMX protocol.

Counterbalance

When the winch has been mounted, it is important to hook on a counterbalance before running with it. This can be done by hanging some sort of load at the end of the wire. The counterbalance is very important, because the winch will not run without it.

Menu setting

Use the push buttons on the display to enter and change menu settings

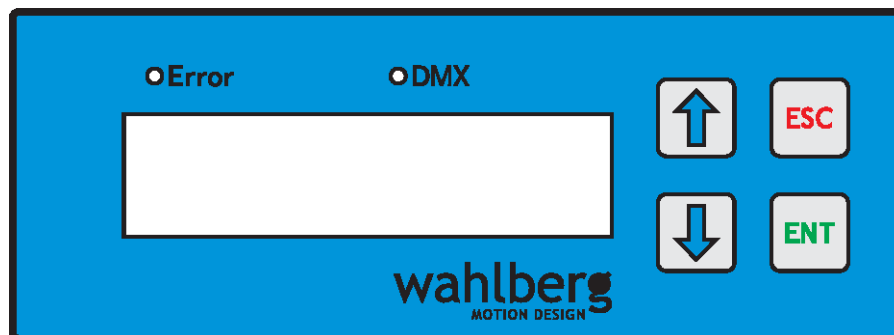

Use the arrows  &  to go up or down in the menu

Push  to set values.

Push  to go back one level in the menu

Menu structure

The menu structure is divided into two different areas for safer motor control.

Control mode

The display shows:

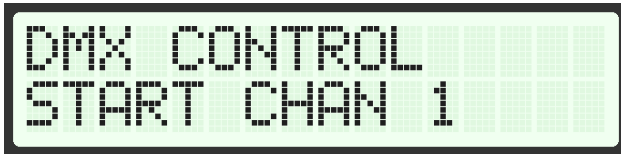

Shift to next screen by pushing  and hold for 3 seconds:

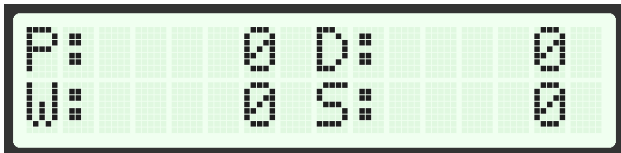

P: Current position (values from 0-50000)
 W: Wanted position (values from 0-50000)
 D: Distance from current to wanted position (maximum shown value 3500)
 S: Speed (values from 0-100)

The screen shows the TAC value for the current position, wanted position, distance and speed.

E.g. the winch is moving with 100% speed from current position with TAC value 10,000 and the wanted position has the TAC value 24,250:

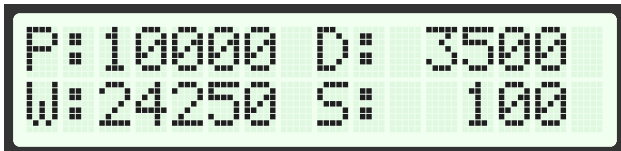

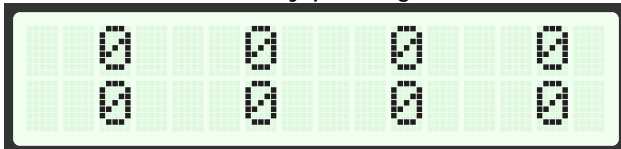

Shift to next screen by pushing  and hold for 3 seconds:

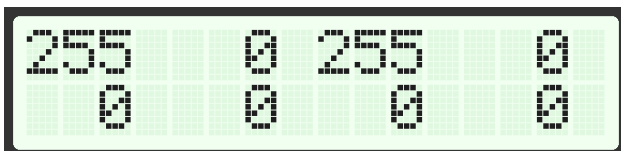

DMX channel 1	DMX channel 2	DMX channel 3	DMX channel 4
DMX channel 5	DMX channel 6	DMX channel 7 (not used)	DMX channel 8 (not used)

The screen shows the DMX channel values, if e.g. DMX channel 1 is set to 100% and DMX channel 3 is set to 100%, the screen will show:



To shift back to the previous screens push  and hold for 3 seconds.

Menu navigation mode

The display shows:

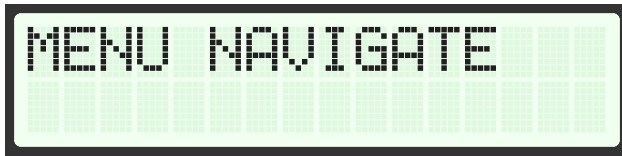

In menu navigate mode, the different parameters can be changed.
In menu navigate mode the motor is stopped and DMX input has no effect, the motor can be moved by the MAN UP/DWN menu though.

Menu mode change

MENU - NAVIGATE:

The top line of the display is showing:

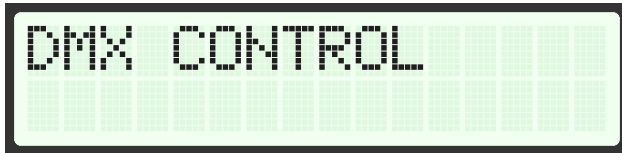

Push both buttons & and hold them for 3 seconds.

Now the top line of the display should show:

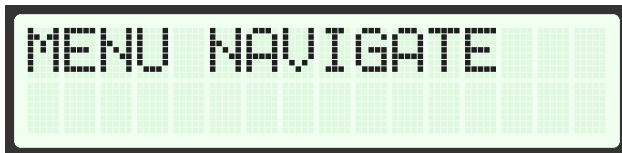

MENU - DMX CONTROL:

Go back to the starting position and activate DMX control

The top line of the display is showing:

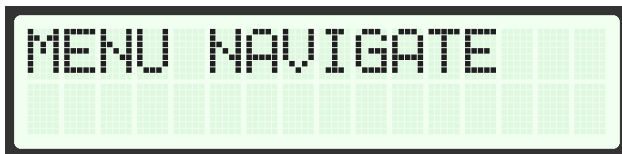

Push both buttons & and hold them for 3 seconds.

Now the top line of the display is showing:

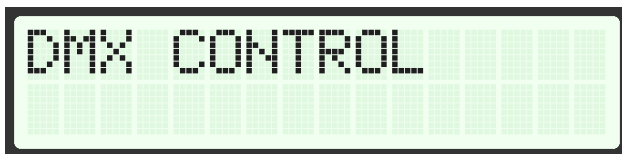

Navigate the menu

The top line of the display is showing:

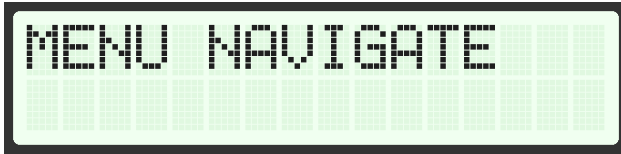

or



Push the arrows to go up or down in the menu choices.

The bottom line of the display is showing:

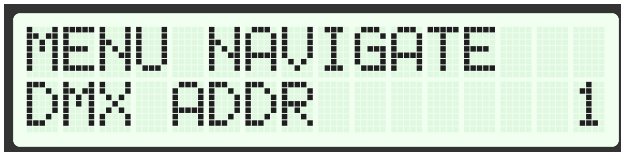

Adjusting menu parameters

The display shows:

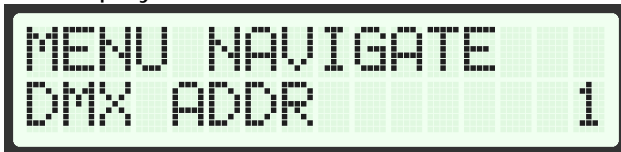

Push to change the *DMX ADDR* value.

The display shows:

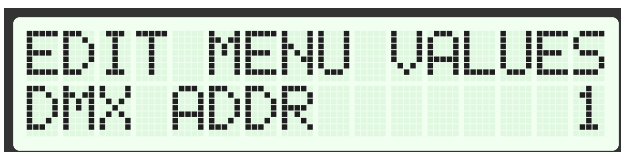

or



Use the arrows to adjust the *DMX ADDR*.

Save changed value

The display shows:

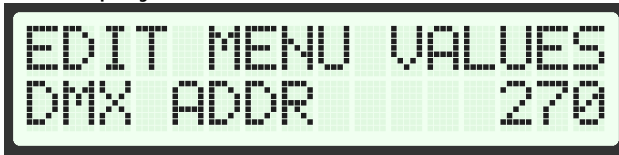

Push  to change the top line to:

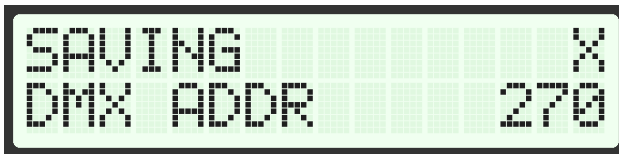

Where X is an increasing number from 1 to 20.



Then push and hold

The top line of the display counts up to 20 then shows *OK*.

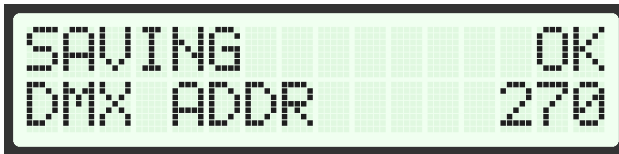

The Value is now saved in the memory.

Adjustable parameters

Menu	Description	Range	Default
MAN SPEED	Speed for manual driving	200 - 2500	800
MAN UP/DWN	Run the motor manual from the menu	MOTOR UP / MOTOR DOWN	
DMX ADDR	DMX start address	1-506	1
TAC RANGE	Tacho range	1-50,000	N/A
SPEED MAX	Maximum speed	500-3,500	3,500
SP MIN UP	Minimum speed UP	50-1,000	200
SP MIN DWN	Minimum speed DWN	50-1,000	200
E STOP	Enable/disable emergency stop	ON/OFF	OFF

MAN SPEED and MAN UP/DWN are used for manual control of the motor.

Detailed explanation of parameters

MAN SPEED	Speed for manual driving	Range	200-2,500
MAN SPEED sets the speed for manual driving the motor			
MAN UP/DWN	Manually driving the motor		
MAN UP/DWN is used for manual control of the motor. Pressing the <i>UP</i> button, makes the wire run up. Pressing the <i>DOWN</i> button, makes the wire run down, unless the limit switch is activated. The winch will stop if the Emergency Switch is activated.			
DMX ADDR	DMX start address	Range	1-506
DMX start address defines which DMX address the Winch 50 reacts on. The Winch 50 uses 6 DMX channels.			
TAC RANGE	Tacho range	Range	1-50,000
The tacho range is setting the maximum range of the Winch			
SPEED MAX	Maximum speed	Range	500-3,500
SPEED MAX sets the maximum speed. If set to 1000, the motor run at 1000 RPM when DMX speed is set to full. SPEED MAX can be used to lower the maximum speed, if desired.			
SP MIN UP	Minimum speed up	Range	50-1,000
The motor minimum speed, for the up direction. The motor is allowed to run at different minimum speeds for each direction; this is to differentiate between different mechanical loads for up and down, see SP MIN DWN. Set this value to a speed where the motor will still run up at full load.			
SP MIN DWN	Minimum speed down	Range	50-1,000
The motor minimum speed, for the down direction. The motor is allowed to run at different minimum speeds for each direction; this is to differentiate between different mechanical loads for up and down, see SP MIN UP. Set this value to a speed where the motor will still run down at full load.			
E STOP	Enable/disable emergency stop	Range	ON / OFF
This enables/disables the emergency stop from the software. However, to get the full functionality of the emergency stop a wire has to be plugged in inside the winch. See section on how to change the wire setting for more details.			

DMX ADDRESS setting

The DMX address, also known as the start channel, is the first channel used to receive instructions from the controller. For independent control, each winch must be assigned its own control channels.

The DMX address is configured using the three DMX ADDRESS selectors on the winch. The selected DMX address states from which channels, on the lighting desk, the winch is controlled. The DMX address can be selected from 1 - 506. The Winch 50 uses 6× DMX channels.

DMX channel overview

DMX channel	Function	Description
1	Position rough	<p>This channel controls the position of the winch, with the speed (DMX channel 3).</p> <p>This rough position works together with the fine position (DMX channel 2).</p> <p>The rough position and the fine position are multiplied in to a 16 bit channel. The rough position is the <i>MSB</i>.</p>
2	Position fine	<p>This channel controls the position of the winch, with the speed set on DMX channel 3.</p> <p>This fine position works together with the rough position (DMX channel 1).</p> <p>The fine position and the rough position are multiplied in to a 16 bit channel. The fine position is the <i>LSB</i>.</p>
3	Speed	<p>This channel controls the speed and defines the max lifting/lowering speed of the winch.</p> <p>This channel also works as a main brake; the motor does not run unless the channel is set above 0%.</p>
4	Motor enable	<p>Channel 4 is used as a security channel. The value on channel 4 needs to be between 50 and 55 %, for the motor to run.</p> <p>All other values make the motor stop.</p> <p>All other values will also reset any error.</p> <p>All other values will save the current position before a power down. If channel 4 is between 50-55% when powering up, the motor will not run.</p>
5	Setting the soft TOP limit	<p>Channel 5 is used to move the wire up. When channel 5 is set $\geq 10\%$ the winch will move up until it reaches the hard TOP limit. 10 - 100% makes the motor run up, at variable speed. (10% = low speed - 100% = full speed).</p> <p>Setting DMX channel 5 to 0 resets the soft TOP limit, to the current position.</p> <p>There is a 3s delay on this channel to reduce risk of accidentally resetting the soft TOP limit.</p>
6	Setting the soft BOTTOM limit	<p>Channel 6 is used to move the wire down and setting the soft BOTTOM limit. When channel 6 is set $\geq 10\%$ the winch will move down, until it reaches the hard BOTTOM limit. 10 - 100% makes the motor run down, at variable speed. (10% = low speed - 100% = full speed).</p> <p>The position is reset and a new TAC RANGE is calculated. The new range is the tacho pulses, between the soft TOP limit set by channel 5 and soft BOTTOM limit set by channel 6.</p> <p>The winch should be reset to the soft TOP limit with channel 5, before the range is set with channel 6.</p> <p>There is a 3s delay on this channel to reduce risk of accidentally setting a new tac range.</p>

Adjusting hard limit switches



Warning! There must be at least 2 rounds left on the drum when the winch is at the hard BOTTOM limit.

Attention! Be careful that the hard TOP limit is not set in a position where the load can run into the winch itself, this will damage the winch.

The hard limit switch determines the maximum and minimum travel distance of the winch. The hard limits are adjusted by rotating the white levers using the screws for hard TOP and BOTTOM limit.

When the hard TOP limit is activated, the display will show:

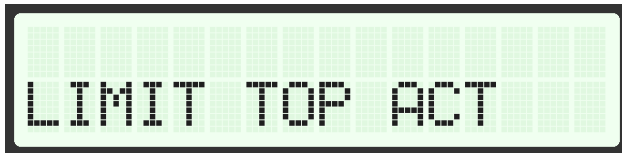

LIMIT TOP ACT

When the hard BOTTOM limit is activated, the display will show:

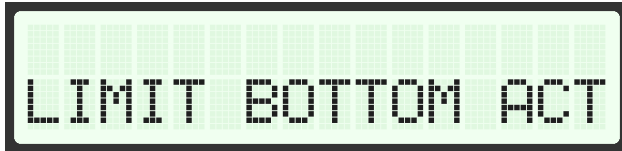

LIMIT BOTTOM ACT

The hard limit switch makes a 'click-sound' when the limit switch is pressed or released.

Adjusting procedure

1. Put the winch in manual mode while adjusting the limits.
2. Localise the hard limit switch box, the black box just beneath the drum.
3. Loosen the two screws holding the lid.

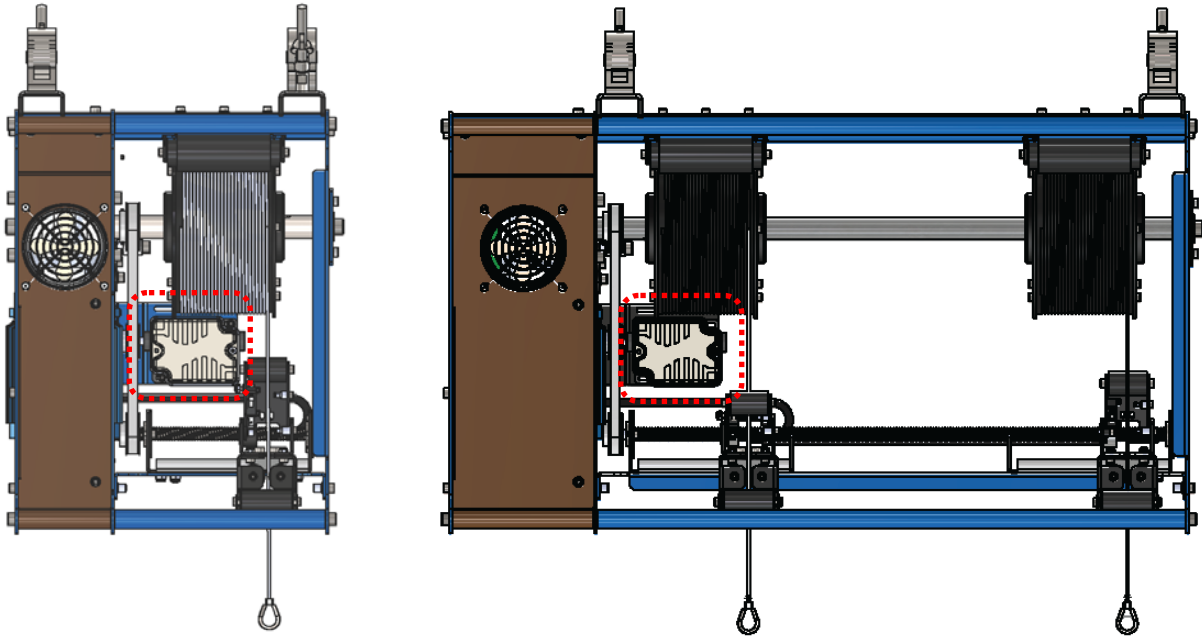

4. Loosen the middle screw.
5. Hard BOTTOM limit is adjusted by turning the screw with a 1 next to it.
6. The hard TOP limit is adjusted by turning the screw with a 2 next to it.
7. When adjustments are done tighten the middle screw again.
8. Mount the lid with the two screws again.

The hard limits are factory pre-set to stop 10 cm below the winch and have a travel length of 10 m. It is not advisable to adjust the hard TOP limit, closer to the winch than 10 cm.

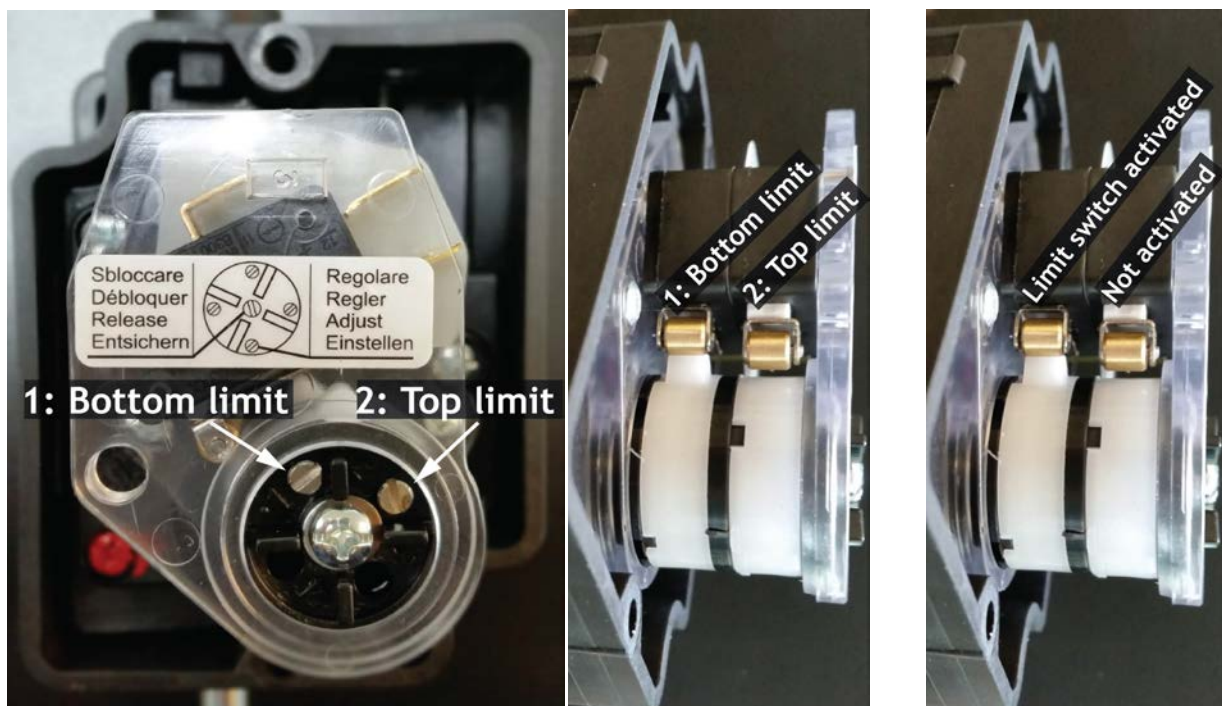

Normal Operation

Temperatures

If the surface temperature of the winch exceeds 90°C (194°F) there is a risk of damaging the winch.

Duty cycle

The winch should not be operated at a duty cycle higher than 30% for longer periods of time.

The duty cycle is the fraction of a period where the motor is active. The duty cycle is commonly expressed as a percentage or a ratio. It can be described as the period of time it takes for a system to complete an on-and-off cycle.

Thus, a 10% duty cycle means the system is on 10% of the time but off 90% of the time. The "on time" for a 10% duty cycle is normally connected to a cycle length in minutes. E.g. a max duty cycle of 30% (10 min ON / 23 min OFF), means that the motor may not be active more than 10 minutes every 33 minutes or after 10 minute of ON the motor must be OFF for 23 minutes.

Lifting speeds and weight

The load of the winch impacts the minimum speed it can operate at. At heavy loads the minimum speed up must be increased to a point where the winch can still move.

If a light load is used with high minimum speeds the winch might have problems with finding its position. Lower the minimum speeds if this is a problem.

The minimum speed can be adjusted from the menu.

Wire fleet

Because of the way the winch rolls up the wire, the place where the wire comes out of the winch changes depending on how much wire has been rolled out. The wire moves 83 mm sideways from the hard TOP to BOTTOM limit during the movement.

Synchronized movements of multiple winches

If several winches are installed to perform synchronized movements, the best result is achieved by using a fading 16 bit position. The winches have a slight deviation in performance of the motors, so some motors have a slightly higher maximum speed than others.

This difference in speed can be solved by running the winches with fading positions, like when fading conventional light over time, the position of the winch should be faded from one position to another over a certain amount of time. In that way the winches will follow the fade-curve, and multiple winches can follow the same fade curve.

When fading the positions:

1. The speed channel should be set to 100 to gain the highest possible speed.
2. The position channel should be assigned as a 16 bit channel with *MSB* and *LSB*.
3. The speed of the fade needs to be slower than the maximum speed, so the motors have speed enough to follow the fade-curve.

If the fade of the positions is too fast, the winches will move at the maximum speed, and you will see the difference in the motor speed.

If the fade is too slow, the winches will move - stop - move - stop, when the position changes, thus giving a discontinuous movement.

LED Functions

DMX LED

The DMX lamp will be steady green when receiving a DMX signal.
The DMX lamp will flash green if no DMX signal is present.

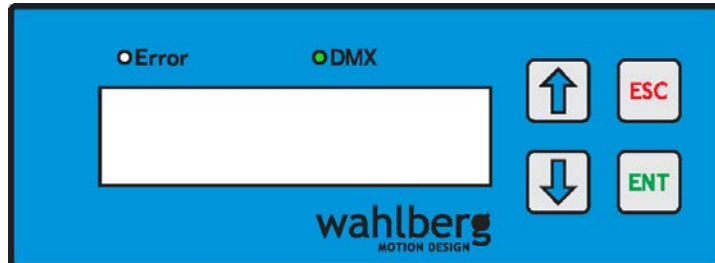

Error LED

The error LED will light red if there is an error.
Reset error is done by setting DMX channel 4 to 0.
When the Error LED lights red, there will also be an error description in the display.

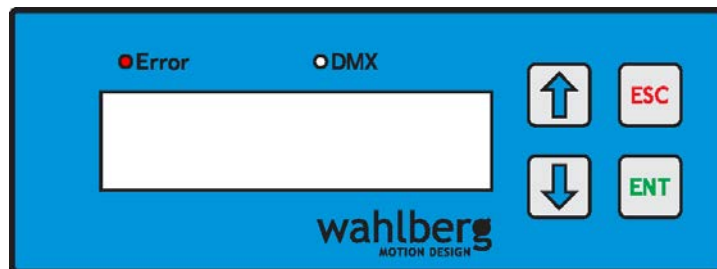

Error and error codes:

Error	Possible solution
Winch will not start, display shows nothing.	Check if the winch is connected to mains power. Check if the fuse in the winch is intact
Winch will not start, DMX lamp is blinking.	Check DMX signal
The wire is not wound up on the drum correctly.	Manually lower the wire totally off the drum, while controlling that the wire comes out of the winch evenly. Afterwards the wire is rolled back onto the drum. Reset the top position afterwards.
Display says "Not in Pos"	The winch cannot move to its position, this usually occurs when the load is high. To solve this go into the menu and increase the Minimum speed up.
Power failure	The winch will stop at power failure. When the power is re-established, the winch has to be reset before it is ready to use. It is advisable to set all the DMX channels on 0% before the power is re-established.

When an error occurs, the control system shuts down the connected motor and issues a corresponding error code. This can be queried, and used to determine the cause of the error.

Code	Error message	Cause	Solution
1	UNDERVOLTAGE	Shutdown due to undervoltage in the DC link.	The input voltage might be too low.
2	OVERVOLTAGE	Shutdown due to overvoltage in the DC link.	The input voltage might be too high.
4	OVERTEMP. >70C	Shut down due to inverter overheat.	<p>The temperature of the power electronics in the frequency inverter is too high.</p> <p>The cooling is insufficient, for example, ambient temperature too high, insufficient air circulation, dirty air grate or the fan is defective.</p> <p>The drive can only be restarted when it has been allowed to cool down.</p>
5	MOTOR OVERTEMP.	Shut down due to motor overheat	<p>This message is issued when the motor thermostat is triggered or the temperature of the motor PTC is exceeded.</p> <p>The motor is being insufficiently cooled, for example, due to a defective fan.</p> <p>The drive can only be restarted when it has been allowed to cool down.</p>
6	INV OVERCURRENT.	Shut down due to inverter overload.	<p>Inverter output current (active current) is too high.</p> <p>Possible cause:</p> <ul style="list-style-type: none"> → The motor load is too high
7	INV OVERCURRENT.	Shut down due to inverter overcurrent.	<p>The momentary output current is permanently exceeding the rated current by more than 150%.</p> <p>Possible causes:</p> <ul style="list-style-type: none"> → The motor load is too high
8	INVERTER EEPROM	Malfunction in the inverter memory.	Power cycle the winch. Unplug the power and wait 30 seconds before applying power again.
9, 64	INVERTER SHORT	This is the switch off function due to a short-circuit on the frequency inverter	<p>The inverter was heavily overloaded (also short term).</p> <p>Causes can be for example:</p> <ul style="list-style-type: none"> a short-circuit / earth fault in the motor or in the supply leads.

10	INV NOT ENABLED	Inverter enable signal missing at the control terminal rail, terminal 3.	<p>The inverter can only be started if an active enabling signal (12-15 V) is applied to the control terminal rail. If this signal fails during drive operations, the motor will shut down and coast to a standstill. The shutdown immediately affects the inverter power section.</p> <p>This signal is provided by an orange wire connected to the number 3 connection on the terminal rail in the winch. If this wire is not connected this error will occur.</p>
11	INV SER TIME OUT	Shutdown when telegrams fail (serial interface).	<p>Power cycle the winch. Unplug the power and wait 30 seconds before applying power again.</p>
255	INV SER TIME OUT	Timer reset of the watchdog.	<p>Power cycle the winch. Unplug the power and wait 30 seconds before applying power again.</p>
12	INVERTER TIMING	Internal timing error	<p>Power cycle the winch. Unplug the power and wait 30 seconds before applying power again.</p>
13	INVERTER SYSTEM	System error	<p>Power cycle the winch. Unplug the power and wait 30 seconds before applying power again.</p>
14	INV START DIRECT	Start attempt with direction error	<p>Power cycle the winch. Unplug the power and wait 30 seconds before applying power again.</p>
15	INV PROGRAM CRC	Program memory CRC error	<p>Power cycle the winch. Unplug the power and wait 30 seconds before applying power again.</p>
16	INV NOT ENABLED	Inverter enabling signal error	<p>The inverter can only be started if an active enabling signal (12-15 V) is applied to the control terminal rail. If this signal fails during drive operations, the motor will shut down and coast to a standstill. The shutdown immediately affects the inverter power section.</p> <p>This signal is provided by an orange wire connected to the number 3 connection on the terminal rail in the winch. If this wire is not connected this error will occur.</p>
17, 250	INV WATCHDOG RST	Reset through WatchDog	<p>Power cycle the winch. Unplug the power and wait 30 seconds before applying power again.</p>

Service and maintenance



Warning! Read "Safety Information" on page 2 before servicing the Winch 50.

Warning! Disconnect the Winch from AC mains power and allow cooling down for at least 10 minutes before handling.

Warning! Refer any service operation not described in this user manual to a qualified service technician.

Attention! Interval of inspections should be determined according to the frequency of use and the working scenario of the winch.

Attention! If the wire runs in an angle the performance degrades and it causes the wire to wear down faster; and shortens the life time of the wire significantly! Wire damage caused by mounting the winch in an angle is not covered by the product warranty.

Attention! Signs of malfunction or poor operation should always lead to an inspection of the winch, and the winch should be taken out of operation until the error is eliminated.

Parts

Only parts ordered at or approved by Wahlberg should be used in the winch to ensure product function and stability. Contact Wahlberg to inquire about spare parts.

On-site service

On-site service and maintenance can be provided by the Wahlberg Motion Design, giving owners access to Wahlberg Motion Design's expertise and product knowledge in a partnership that will ensure the highest level of performance throughout the product's lifetime. Please contact Wahlberg Motion Design for details.

Maintenance plan

The results of all the regular inspections are to be documented and kept available at the company. The written result of the last inspection must be kept available at the site of operation, e.g. by an inspection sticker on the winch showing the date of the inspection, the basis of the inspection and the name of the inspector.

Before every use and weekly

Every time when rigging the winch, before running the winch - and at least every week when the winch is in use:

- Check that the winch is safely and correctly installed/mounted
- Check that the winch's load and LEDs are visible from the operating station
- Check the entire length of the wire rope for bends, crushed areas, broken, or cut cord, corrosion and other damages.
- Check the wire ferrule crimp and thimble
- Check all safety devices (slack detection, limit switches, emergency stop).
- Check the emergency stop.
- Check that the wire is winded neatly on the drum.
- Check that the load is securely mounted

Monthly

At regular intervals - but at least every month when the winch is in use:

- Check the mounting bolts for damages and proper fastening.
- Clean the grid of the ventilator and air outlet
- Control that the overload detection is working.
- Change damaged parts according to this manual.

Yearly

The winch has to be inspected by a specialist every 12 months.

Every 48 months

The winch should be inspected by an authorised expert every 48 months.

Checklist

Use the checklist accordingly; before each use, each month etc.

Check	Type	Result
Installed / mounted correct	Inspection	
Load and LEDs visible for the operator	Inspection	
Entire wire length OK	Inspection	
Slack detection	Functional test	
Overload	Functional test	
Emergency stop	Functional test	
Wire is winded neatly around the drum	Inspection	
Wire ferrule crimp	Inspection	
Wire thimble	Inspection	
Load mounted safely	Inspection	

Life of the wire

It is Wahlberg policy to apply the strictest possible calibration procedures and use the best quality materials available to ensure optimum performance and the longest possible component lifetimes. However, wires are subject to wear and tear over the life of the product, resulting in special attention to the state of the wire. The extent of wear and tear depends heavily on operating conditions and environment, so it is impossible to specify precisely whether and to what extent the wire performance will be affected.

The expected lifetime of the wire depends on the load and travel length as well as duty cycle.

Wire discard criteria

When the wire rope is exposed, the following guidelines can be used to control whether the wire must be discarded. The following serves as guidelines and if any of the discard criteria are reached, the winch must immediately be taken out of service, and the wire replaced, before using the winch again.

The wire rope should be discarded when:

- When the overall diameter of the rope is reduced by 8 %, or the outer wires have lost its diameter by 33 % through wear. This reduction in diameter of the rope is measured on a portion of the rope which has been subjected to abrasion and stresses with respect to the portion of the rope which is subjected to stresses but not abrasion e.g. portions near drum or anchorage.

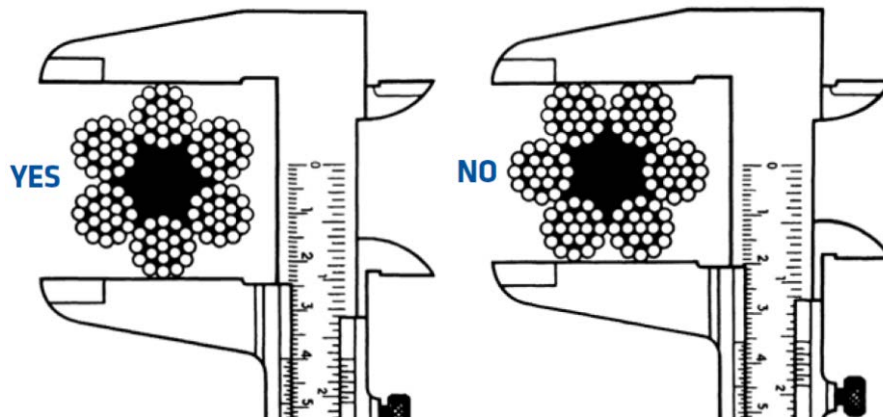
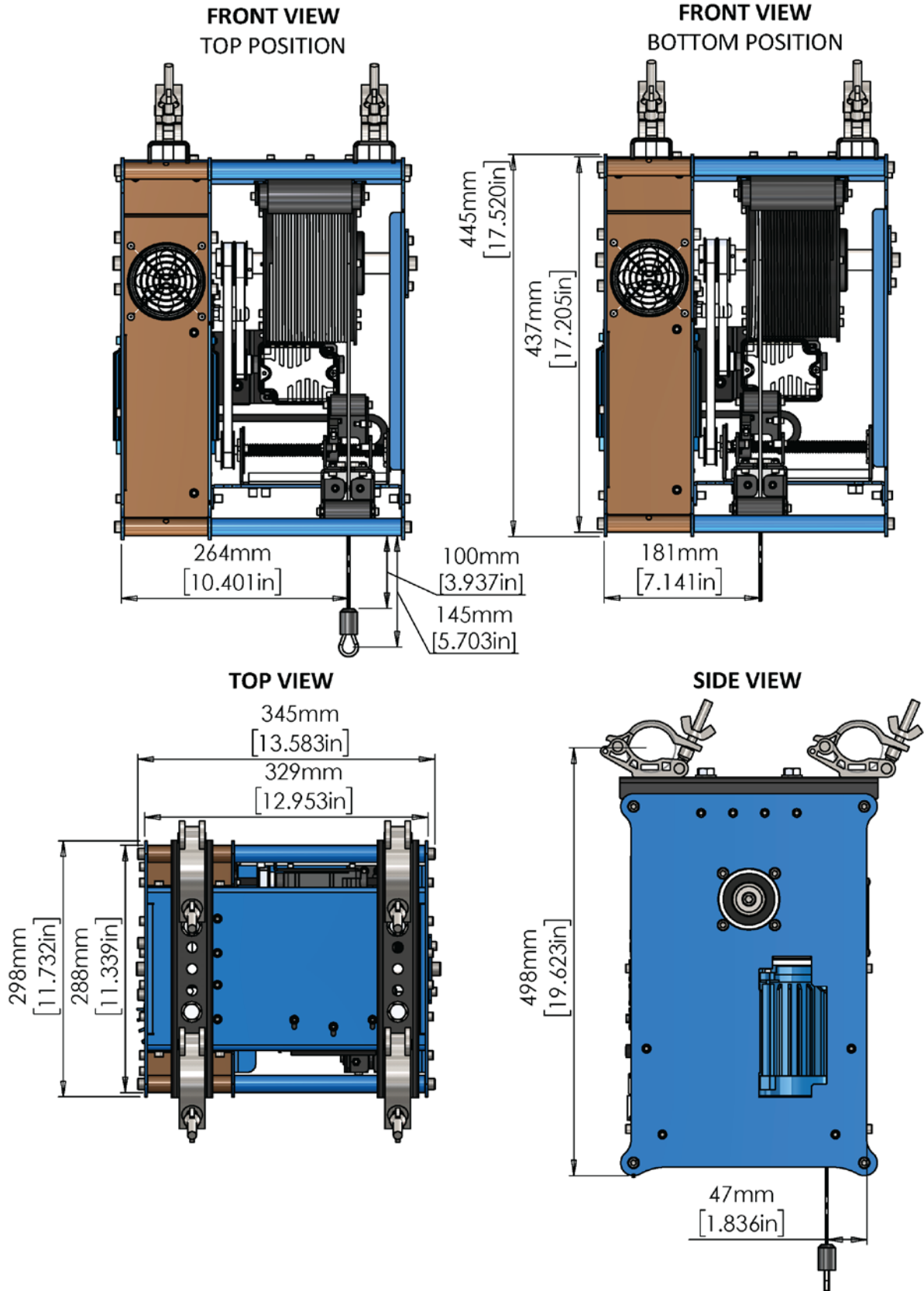

Figure 1: When using a calliper to measure wire rope diameter, measure from crown to crown, not from valley to valley.

- When there is evidence of considerable plastic wear or surface embrittlement.
- When the diameter of the rope has suddenly reduced or the lay length has suddenly increased or decreased.
- When there is evidence of severe corrosion like chain pitting.
- When there is any evidence of internal corrosion in the rope. This can be recognized by slackness of outer wires due to the internal wires corroding away.
- When the rope has been subjected to mechanical damage, crushing, kink, bends, bird cage, etc.
- When the core of the rope has collapsed.
- When the rope has been subjected to a high temperature or heat due to fire.
- When the rope has been subjected to severe shock load or over load due to an accident with the winch.

Appendix 1

Winch 50 (245)



Appendix 2

Winch 50 Double (246.701)

**FRONT VIEW
TOP POSITION**

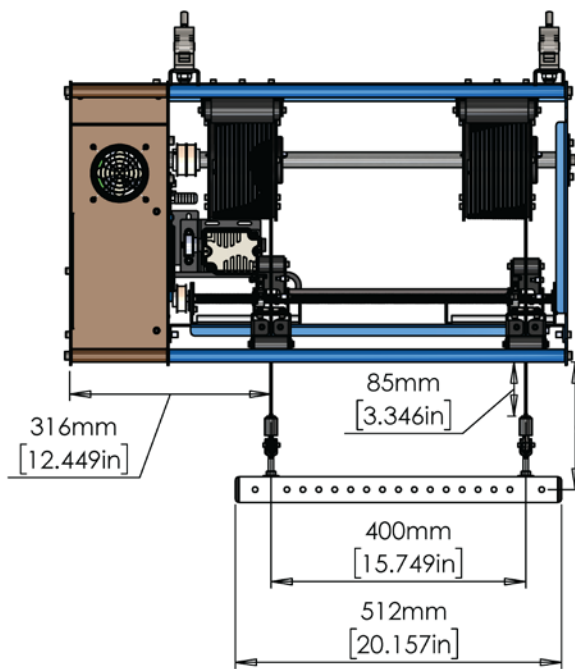

**FRONT VIEW
BOTTOM POSITION**

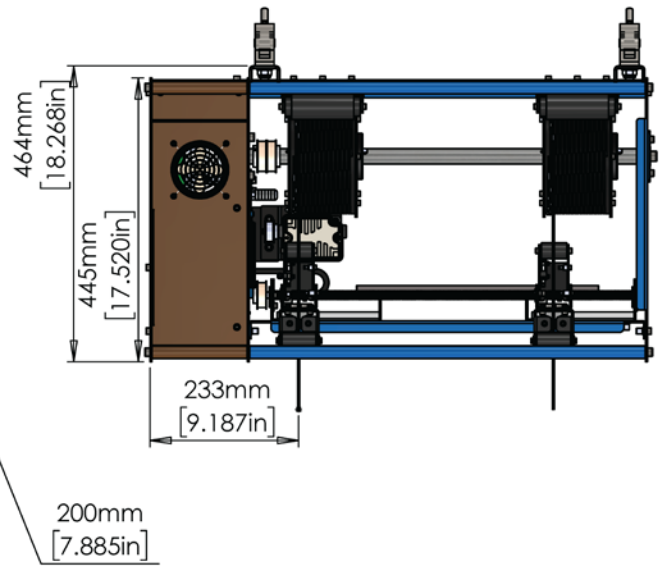

TOP VIEW

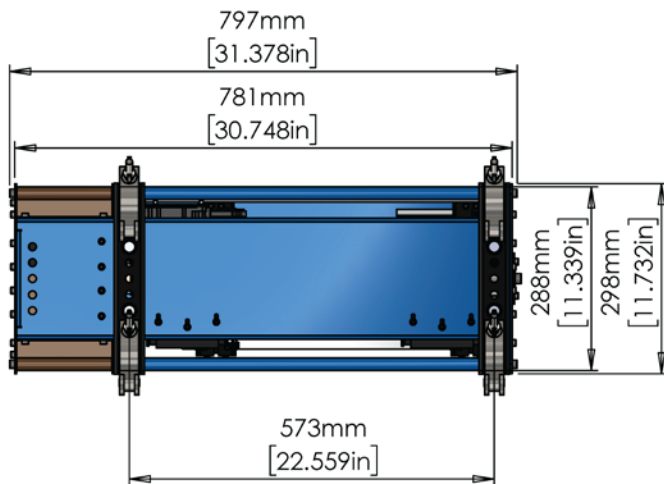

SIDE VIEW

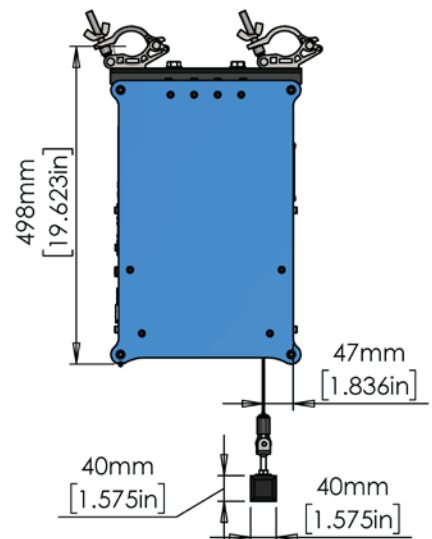

Appendix 3



OPERATING & ASSEMBLY INSTRUCTION NAC3FX-W | powerCON TRUE1

A. OPERATING INSTRUCTION

Application:

The powerCON TRUE1 system is certified as connector with breaking capacity according IEC 60320, VDE 0625. It is intended for use as appliance couplers and interconnection couplers. It serves to supply power to an appliance and from an appliance to another equipment. To be installed by qualified person only.

Connector Assignment:

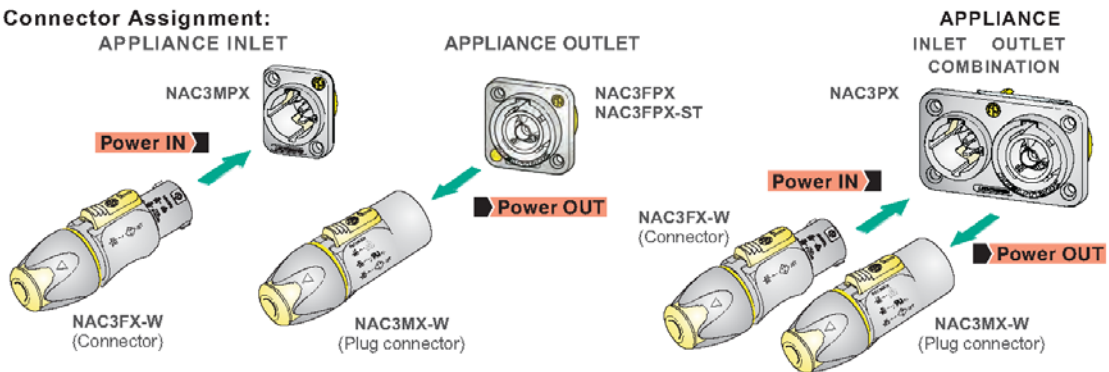

Approval based:	VDE EN 60320-1/EN60320-2-2	<input checked="" type="checkbox"/>	UL UL 498 / CSA C22.2 No. 182.3	<input checked="" type="checkbox"/>
Rating:	250 V ac / 16 A		250 V ac / 20 A	
Cable Type:	H05VV-F3G 1.0 mm ² , Length max. 2 m H05VV-F3G 1.5 - 2.5 mm ² H07RN-F3G 1.5 mm ²		SJTOW, SJOOW 3 x 12 AWG	
Strain Relief:	White chuck		White chuck	
Cable O.D.:	6.0 - 12.0 mm		6.0 - 12.0 mm	

B. ASSEMBLY INSTRUCTION

- A** Insert cable into the bushing and housing.

Note: "Apply cable pulling lubricant to cable jacket."

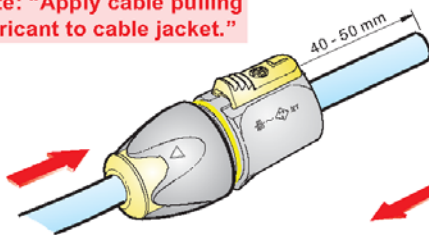

- B** Separate the housing from the bushing (cable remain in bushing)

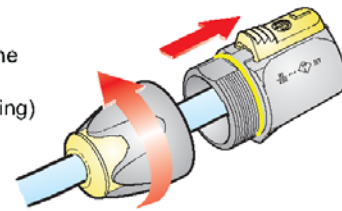

- C** Place chuck over the cable.

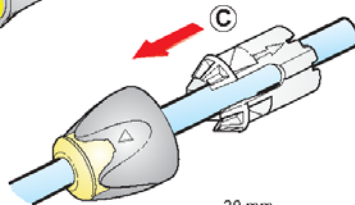

i Recommendation:

Wire Pulling Lubricant - LUB-I/0.95 from 3M™

- D** Prepare cable as shown.

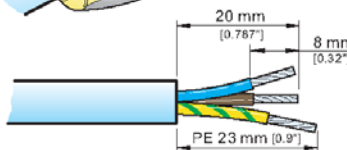

VDE (EN 60320-1/EN60320-2-2)

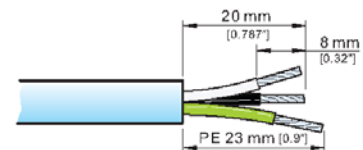

UL (UL 498 / CSA C22.2 No. 182.3)

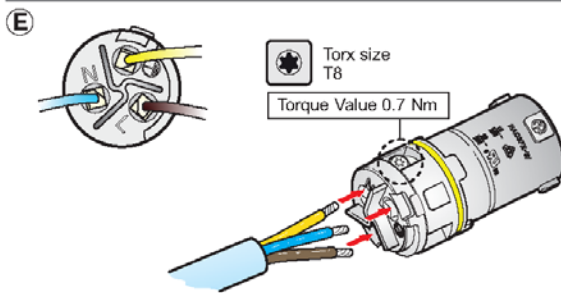

Slide the cable into the contacts and clamp with the screw with Torx size T8.

Wiring	VDE	UL
L ⇒	brown	black
N ⇒	blue	white
⏚ ⇒	green/yellow	green

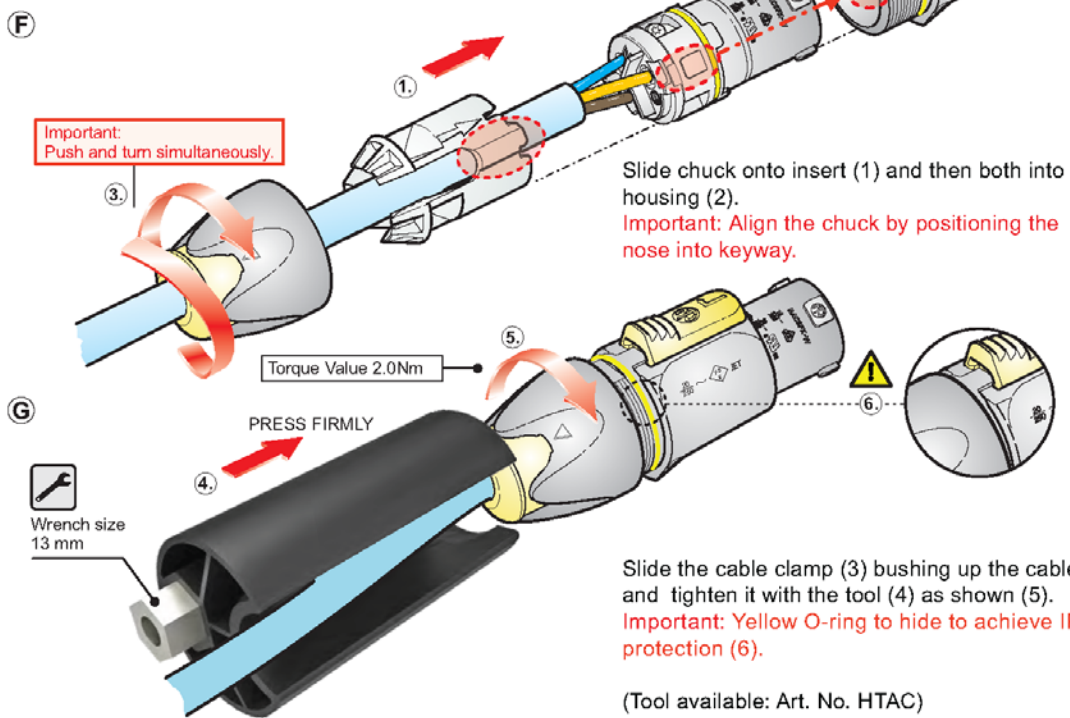

FOR DISASSEMBLY - OPEN TWIST LOCK!

1. Press with screw driver to unlock
2. Turn bushing 360°.
3. Repeat step 1+2 until bushing is unscrewed.

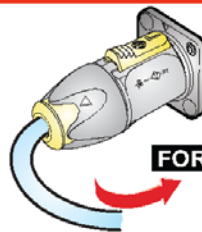
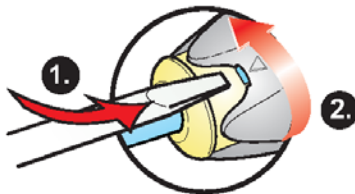

CAUTION

To ensure protection category, do not expose the connection to bending forces (e.g. do not attach loads to the cable, no free-dangling cable windings etc.).



SAFETY WARNING

For safety and certification reasons the connector must be replaced in case of any broken parts or serious damage.

NEUTRIK AG	LI	T: +423 / 237 24 24	F: +423 / 232 53 93	NEUTRIK France	FR	T: +33 1/4131 6750	F: +33 1/4131 0511
NEUTRIK USA Inc.	USA	T: +1 704 / 972 3050	F: +1 704 / 438 9202	NEUTRIK Tokyo Ltd.	JP	T: +81 3/3663 4733	F: +81 3/3663 4796
NEUTRIK (UK) Ltd.	UK	T: +44 1983 / 811441	F: +44 1983 / 811 439	NEUTRIK Hong Kong Ltd.	HK	T: +852 / 2687 6055	F: +852 / 2687 6052
NEUTRIK Vertriebs GmbH	DE/NL/AT/DK	T: +49 8131 / 280 880	F: +49 8131 / 280 830	NEUTRIK India Pvt. Ltd.	IND	T: +91 / 982 05 43 424	F: +91 / 22 26163 540

Draft. Nr.: BDA 378 | Update: 09.06.2017 | Data subject to change without prior notice. ©2017 NEUTRIK®. ALL RIGHTS RESERVED. NEUTRIK® and powerCON® is a registered trademark.

Appendix 4

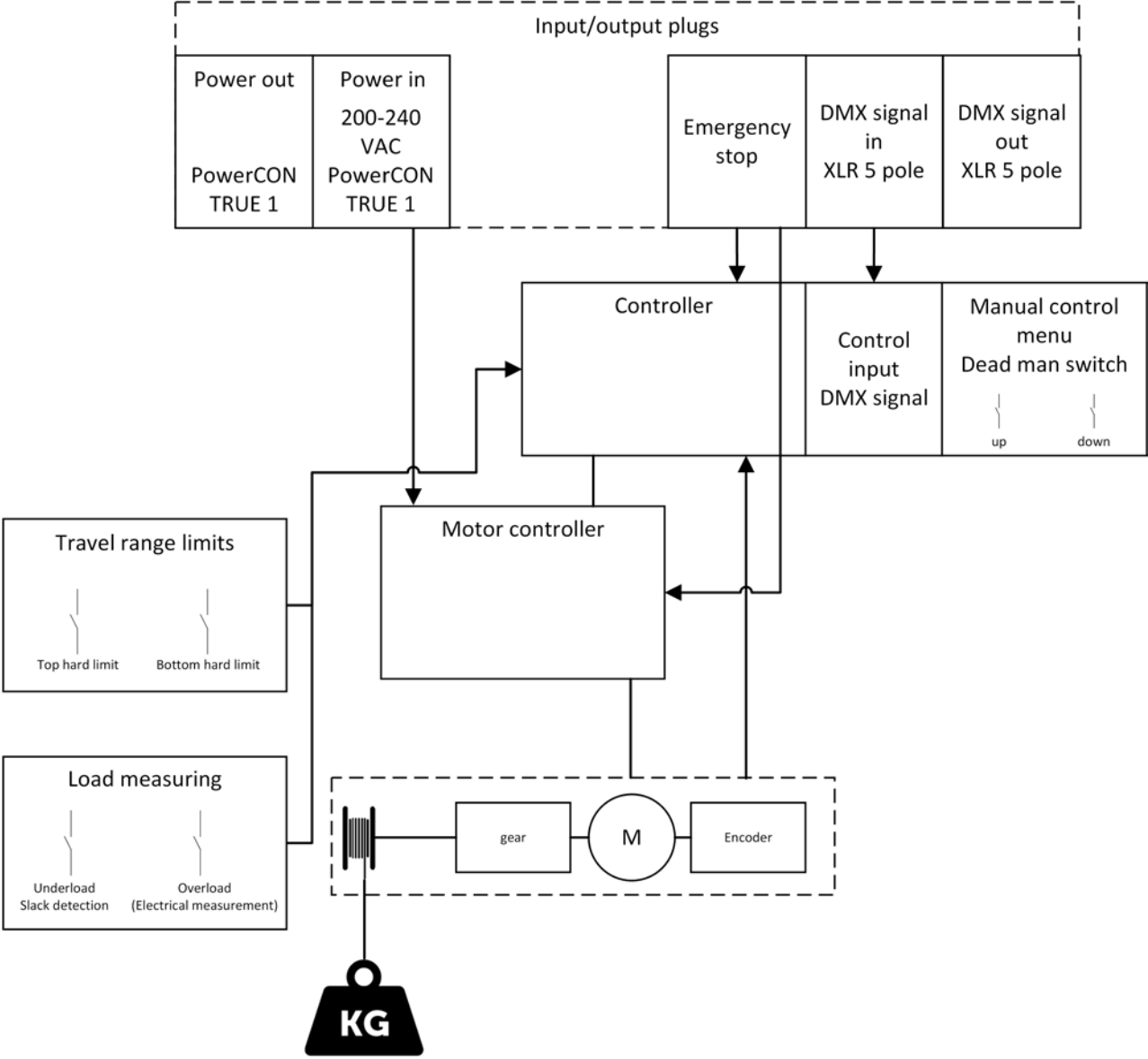

Block diagram of the control system of the winch.

[This page is intentionally left blank]

Winch 50 - Cheat Sheet

DMX channels	Function
1	Position rough (Hi of a 16 bit DMX channel)
2	Position fine (Lo of a 16 bit DMX channel)
3	Set the maximum speed
4	Motor Enable - between 50% and 55% to enable the motor output
5	Setting soft TOP limit
6	Setting soft BOTTOM limit

How to get started

1. Place / Rig the winch in something high with minimum 2-3 meter clearance below. Put on counterweight on the winch, minimum 5 kg (11 lb) maximum 50 kg (110 lb).
2. Connect the winch to 230VAC - The winch turns on and the display shows the start-up message.
3. Connect emergency switch (if enabled) - make sure the error LED no longer is glowing red.
4. Set the DMX start address to 1 and apply DMX from a lighting desk, preferably with manual faders. Make sure that the 6 channels are patched from DMX channel 1 to 6. Pull all channels on to 0%
5. Set DMX channel 4 between 50% and 55% - the motor is now enabled
6. Set DMX channel 5 to 30% - After 3s the winch moves towards its hard TOP limit. To stop the winch, set DMX channel 5 to 0%. Stop when desired or at the hard TOP limit. The reached position is now the soft TOP limit.
7. Set DMX channel 6 to 50% - The winch moves towards its hard BOTTOM limit. To stop the winch, set DMX channel 6 to 0%. Stop when desired or at the hard BOTTOM limit. The reached position is the soft BOTTOM limit, and hence the travel range has now been set: from the soft TOP limit to the soft BOTTOM limit.
8. Set DMX channel 1 to 100% and DMX channel 3 to 20% - The winch moves with 20% speed to the 100% position.
9. Set DMX channel 1 to 90% and DMX channel 3 to 50% - The winch moves with 50% speed to the 90% position.

Emergency stop switch (Only when emergency stop is enabled)

The emergency stop switch is connected to the female 4 pin XLR connector.

Pin 1 and Pin 2 should be connected to each other; otherwise the motor will not run.

Pin out:

Pin 1	GND	Emergency stop input
Pin 2	NC	
Pin 3	NC	
Pin 4	12-15 volt DC	Emergency stop input

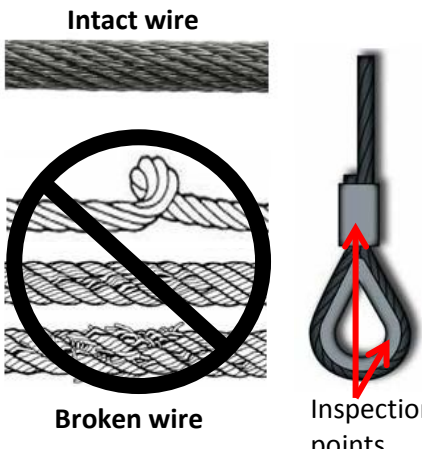

Before each use

- Check that the winch is safely and correctly installed/mounted.
- Inspect the entire length of the wire rope for bends, damage and wear, cut cords, corrosion and abuse.
- Inspect the wire ferrule crimp and thimble for damage, wear, corrosion or abuse.
- Check the load is safely mounted and weighs max. 50 kg (110.2 lb).
- Check safety functions (limit switches, slack detection, emergency stop)
- Check that the wire is winded neatly on the drum

Warning! Do not use the winch if any damage or error is found!