

**PHILIPS**

**VARI\*LITE®**

**VLX™ Wash Luminaires**



**USER'S MANUAL**

**VARI\**LITE***® is a trademark owned by Genlyte Thomas Group LLC and is registered in the United States and other countries.

**VL500**™ (and the individual product designations), **VL1000**™, **VL2000**™, **VL2201**™, **VL2202**™, **VL2400**™ (and the individual product designations), **VL2500**™, **VL3000**™, **VL3500**™, **VLX**™, **Series VLX**™, **Series 500**™, **Series 1000**™, **Series 2000**™, **Series 3000**™, **DICHR0\*TUNE**™, **VARI\**IMAGE***™, **VARI\**BRITE***™ and the Vari-Lite Asterisk are also trademarks owned by Genlyte Thomas Group LLC.

**VARI\**LITE***® products are protected by one or more of the following patents, and other pending patent applications worldwide:

U. S. Patents No. 6,123,436; 6,113,252; 6,046,861; 6,031,749; 6,011,640; 5,969,868; 5,959,768; 5,934,794; 5,882,107; 5,829,868; 5,825,548; 5,798,619; 5,774,273; 5,769,527; 5,758,956; 5,728,994; 5,640,061; 5,590,954; 5,454,477; 5,432,691; 5,367,444; 5,329,431; 5,307,295; 5,282,121; 5,278,742; 5,209,560; 5,186,536; 5,073,847; 5,010,459; 4,980,806; 4,972,306; 4,800,474; 4,779,176; 4,701,833; 4,602,321;

U. S. Design Patents No. 439,356; 420,332; 417,300; 415,301; 413,995; 377,338; 366,712; 359,574; 350,408; 347,113;

Australia Patents No. 693,691; 683,695; 667,109; 649,264; 646,588; 586,095; 576,400; 546,433;

Australia Design Patents No. 128,796; 128,795;

Canada Patents No. 2,070,670; 2,050,375; 1,270,675; 1,259,058; 1,181,795;

Canada Design Patents No. 81,234; 81,233; 76,046;

European (UK) Patents No. 0 652 400; 0 586 049; 0 565 218; 0 547 732; 0 534 710; 0 495 305; 0 474 202; 0 379 970; 0 253 082; 0 253 081; 0 248 974; 0 192 882; 0 140 994; 0 060 068;

Germany Patents No. 694 25 943.8; 693 14 122.0; 692 08 615.3; 692 07 692.1; 691 31 478.0; 691 21 029.2; 690 33 385.4; 37 89 166.9; 37 68 727.1; 37 51 804.6; 37 50 201.8; 35 87 270.5; 32 79 888.1; 32 74 291.6;

Germany Design Patents No. M 98 01 745.4; M 96 04 515.9; M 96 04 514.0; M 94 07 689.8; M 94 02 951.2; M 499 03 583.6; M 498 11 203.9; G 93 12 884.3;

Spain Patents No. 2 090 191; 2 084 289; 2 020 960; 0 548 328;

Spain Utility Model Patent No. 2.031.748;

Spain Design Patents No. 0.137.502; 0.137.501; 0.133.573;

Greece Patent No. 910.400.544;

Hong Kong Patents No. 965/1990; 285/1987;

Japan Patents No. 2,843,696; 2,059,669; 2,055,324; 2,002,168; 1,966,525; 1,889,481; 1,792,721; 1,770,241; 1,723,825; 1,683,007; 1,533,011;

Japan Design Patents No. 985,985-1; 985,985; 947,552; 945,436-1; 945,436; 1,106,089; 1,077,598; 1,072,598; 1,060,414; 1,002,123;

Korea Patents No. 76,310; 42,639; 283,770; 181,180;

Korea Design Patents No. 209,896; 209,895;

Mexico Patent No. 180,148;

Singapore Patents No. 663/90; 134/87;

Taiwan Patents No. 78,726; 66,975; 65,380; 28,275;

United Kingdom Design Registrations No. 2082526; 2072562; 2056387; 2056386; 2042174; 2038212; 2033108; 2029499.

All other brand or product names which may be mentioned in this manual are trademarks or registered trademarks of their respective companies or organizations.

### **VLX™ Wash Luminaire User's Manual**

The information furnished in this manual is for informational use only and is subject to change without notice. Please check [www.vari-lite.com](http://www.vari-lite.com) for latest version. Vari-Lite assumes no responsibility or liability for any errors or inaccuracies that may appear in this manual. All information and graphics are property of Vari-Lite, a Philips group company, 10911 Petal Street Dallas, Texas 75238 USA.

Version as of: **07 August 2009 (Preliminary)**

Part number: **02.9690.0001 0**

## **How To Obtain Warranty Service**

A copy of the Vari-Lite Limited Warranty was included in the shipping package for this VARI\*LITE® product.

To obtain warranty service, please contact customer service at 1-877-VARI-LITE (1-877-827-4548), +1-214-647-7880, or [customerservice@genlytecontrols.com](mailto:customerservice@genlytecontrols.com) and request a Return Material Authorization (RMA) for warranty service. You will need to provide the model and serial number of the item being returned, a description of the problem or failure and the name of the registered user or organization. If available, you should have your sales invoice to establish the date of sale as the beginning of the warranty period.

Once you obtain the RMA, pack the unit in a secure shipping container or in its original packing box. Go to the Vari-Lite web site [www.vari-lite.com](http://www.vari-lite.com), click on the Support link, and download the RMA form. Put the completed RMA form in shipping container along with a copy of your invoice (if available). Write the RMA number legibly on or near the shipping address label and return the unit, freight prepaid to:

**Vari-Lite**  
**Attention: Warranty Service (RMA# \_\_\_\_\_)**  
**10911 Petal Street**  
**Dallas, Texas 75238 USA**

As stated in the warranty, it is required that the shipment be insured and FOB our service center.

## Compliance Notice

**FCC** This equipment has been tested and found to comply with the limits for a Class A digital device pursuant to Part 15 of FCC Rules. These limits are designed to provide reasonable protection against harmful interference when this equipment is operated in a commercial environment. This equipment generates, uses, and can radiate radio frequency energy and, if not installed and used in accordance with Vari-Lite system, service, and safety guidelines, may cause harmful interference to radio communications. Operation of this equipment in a residential area is likely to cause harmful interference, in which case the user will be required to correct the interference at his/her own expense.



### Declaration of Conformity

We declare, under our sole responsibility, that this product complies with the relevant clauses of the following standards and harmonized documents:

#### Safety

EN 60598-1:2000 Luminaire Safety Standard, General Requirements

EN 60598-2-17:1989/A2: 1991 Specification for Luminaires for Stage and Studio Lighting

#### EMC

EN 61000-6-4:2001 Emission Standard for industrial environments

We certify that the product conforms to the protection requirements of council directives: 73/23/EEC (LVD) and 89/336/EEC (EMC)

## Safety Notice

It is extremely important to read ALL safety information and instructions provided in this manual and any accompanying documentation before installing and operating the products described herein. Heed all cautions and warnings during installation and use of this product.

Safety symbols used throughout this manual are as follows:



**CAUTION** advising of potential damage to product.



**WARNING** advising of potential injury or death to persons.

GENERAL INFORMATION PERTAINING TO PROTECTION AGAINST ELECTRICAL SHOCK, FIRE, EXPOSURE TO EXCESSIVE UV RADIATION, AND INJURY TO PERSONS CAN BE FOUND BELOW.

### **WARNING:**

#### **INSTRUCTIONS FOR CONTINUED PROTECTION AGAINST FIRE**

1. VARI\*LITE® luminaires have been designed for use with specific lamp types. The VLX™ Wash Luminaire uses special LED devices. Installing another type of light sources may be hazardous.
2. Luminaires may be mounted on any type of surface as long as mounting instructions are followed. See instructions detailed in this manual.
3. Note distance requirement from combustible materials or illuminated objects for VARI\*LITE® luminaires.

### **WARNING:**

#### **INSTRUCTIONS FOR CONTINUED PROTECTION AGAINST ELECTRICAL SHOCK**

1. VARI\*LITE® luminaires are designed for dry locations only. Exposure to rain or moisture may damage luminaire.
2. Disconnect power before servicing any VARI\*LITE® equipment.
3. Servicing to be performed by qualified personnel only.

**WARNING:**

**INSTRUCTIONS FOR CONTINUED PROTECTION AGAINST EXCESSIVE EXPOSURE TO UV RADIATION**

1. Many VARI\*LITE® luminaires use a lamp that produces UV radiation. DO NOT look directly at lamp.
2. It is hazardous to operate luminaires without lens or shield. Shields, lenses, or ultraviolet screens shall be changed if they have become visibly damaged to such an extent that their effectiveness is impaired. For example, by cracks or deep scratches.

**WARNING:**

**INSTRUCTIONS FOR PROTECTION AGAINST INJURY TO PERSONS**

1. Exterior surfaces of the luminaire will be hot during operation. Use appropriate safety equipment (gloves, eye protection, etc.) when handling and adjusting hot equipment and components.
2. Luminaires will have a hot lamp when operating. Disconnect power and allow lamp to cool before replacing.
3. Arc lamps emit ultraviolet radiation which can cause serious skin burn and eye inflammation. Additionally, arc lamps operate under high pressure at very high temperatures. Should the lamp break, there can exist a danger of personal injury and/or fire from broken lamp particles being discharged.
4. Wear eye protection when relamping.
5. Appropriate safety equipment (gloves, eye protection) should be used when handling damaged lamps.
6. If lamp is touched with bare hands, clean lamp with denatured alcohol and wipe with lint-free cloth before installing or powering up the luminaire.
7. The lamp shall be changed if it has become damaged or thermally deformed.

**WARNING:**

**RF INTERFERENCE**

1. This is a Class A product. In a domestic environment this product may cause radio interference, in which case, the user may be required to take adequate measures.

**ARC LAMP CHARACTERISTIC CONSIDERATIONS**

1. Arc lamps require a period of time to relight after a power interruption or a severe voltage dip. In some cases, lamp will automatically relight after it has cooled depending on Lamp Power-Up State configuration setting.
2. Burning position is Universal.

## Sicherheitshinweise

Es ist äußerst wichtig, ALLE Sicherheitsinformationen und -hinweise in diesem Handbuch und dem beiliegenden Informationsmaterial zu lesen, bevor Sie die hierin beschriebenen Produkte installieren bzw. bedienen. Halten Sie bei der Installation und dem Einsatz dieses Produkts alle Warnhinweise und Vorsichtsmaßnahmen ein.

Folgende Sicherheitssymbole werden in diesem Handbuch verwendet:



**VORSICHT** - weist auf möglichen Produktschaden hin.



**WARNUNG** - weist auf mögliche Körperverletzung und Lebensbedrohung hin.

NACHSTEHEND FINDEN SIE ALLGEMEINE HINWEISE ÜBER SICHERHEITSVORKEHRUNGEN GEGEN ELEKTROSCHOCK, FEUER, ÜBERHÖHTE UV-STRAHLUNG UND KÖRPERVERLETZUNGEN.

### **WARNUNG:**

#### **HINWEISE ZUM FEUERSCHUTZ**

1. VARI\*LITE®-Scheinwerfer sind ausschließlich für den Einsatz mit bestimmten Lampentyps. Achten Sie auf den Lampentyp (LED), bevor Sie die jeweiligen Lampen ersetzen. Die Installation eines anderen Lampentyps kann gefährlich sein.
2. Scheinwerfer können auf jeder beliebigen Oberfläche montiert werden, solange Sie die Montageanweisungen befolgen. Detaillierte Hinweise finden Sie in diesem Handbuch.
3. Beachten Sie die Einhaltung des erforderlichen Sicherheitsabstandes der VARI\*LITE®-Scheinwerfer von brennbarem Material oder beleuchteten Objekten.

### **WARNUNG:**

#### **HINWEISE ZUM SCHUTZ GEGEN ELEKTROSCHOCK**

1. VARI\*LITE®-Scheinwerfer eignen sich ausschließlich für trockene Standorte. Regen oder Feuchtigkeit können die Scheinwerfer beschädigen.
2. Unterbrechen Sie die Stromzufuhr, bevor Sie mit der Arbeit an VARI\*LITE®-Geräten beginnen.
3. Die Geräte sollten nur von qualifiziertem Personal gewartet werden.

**WARNUNG:**

**HINWEISE ZUM SCHUTZ GEGEN ÜBERHÖHTE UV-STRAHLUNG**

1. Viele VARI\*LITE®-Scheinwerfer verwenden die Lampentyp, der UV-Strahlen abgibt. SCHAUEN SIE NICHT direkt in die Lampe.
2. Es ist gefährlich, Leuchten ohne Linsen oder Blenden zu bedienen. Blenden, Linsen oder Ultraviolettscirme müssen ausgetauscht werden, sofern deren Schutzwirkung durch sichtbare Beschädigung (z. B. Sprünge oder Schrammen) eingeschränkt ist.

**WARNUNG:**

**HINWEISE ZUM SCHUTZ GEGEN KÖRPERVERLETZUNGEN**

1. Bei Betrieb sind die Außenflächen der Scheinwerfer heiß. Verwenden Sie bei der Bedienung von aufgeheizter Apparatur die jeweils geeignete Sicherheitsausrüstung (Handschuhe, Augenschutz etc.).
2. Bei Betrieb der Scheinwerfer ist die Lampe heiß. Unterbrechen Sie die Stromzufuhr und lassen Sie die Lampe abkühlen, wenn Sie diese austauschen.
3. Bogenlampen senden ultraviolette Strahlen aus, die Hautverbrennungen und Augenentzündungen verursachen können. Der Betrieb von Bogenlampen erfolgt unter Hochdruck und bei hohen Temperaturen. Sollte die Lampe zerbrechen, besteht die Gefahr von Körperverletzung bzw. von Feuer, das von Lampenteilen ausgelöst werden kann.
4. Tragen Sie beim Austausch der Lampen einen Augenschutz.
5. Die geeignete Sicherheitsausrüstung (Handschuhe, Augenschutz) sollte beim Umgang mit beschädigten Lampen verwendet werden.
6. Wenn die Lampe mit bloßen Händen berührt wird, reinigen Sie sie mit denaturiertem Alkohol und einem flusenfreien Tuch, bevor Sie die Scheinwerfer installieren oder in Betrieb nehmen.
7. Wenn die Lampe beschädigt oder durch Hitzeeinwirkung deformiert ist, muß diese ausgetauscht werden.

**WARNUNG:**

**HF-INTERFERENZ**

1. Es handelt sich um ein Produkt der Klasse A. In einer Wohnumgebung kann das Produkt Hochfrequenzstörungen verursachen. In diesem Fall müssen eventuell geeignete Maßnahmen getroffen werden.

**BESONDERHEITEN VON BOGENLAMPEN**

1. Bogenlampen benötigen eine gewisse Zeitdauer, um nach einem Stromausfall oder einem Spannungsgefälle wieder aufzuleuchten. In einigen Fällen wird die Lampe nach Abkühlung automatisch wieder aufleuchten, je nach der Systemkonfigurationseinstellung des Lampeneinschaltungsstatus.
2. Die Brennposition ist Universal.



## Notes de sécurité

Avant de procéder à l'installation des produits décrits dans ce guide et de les mettre en marche, il est extrêmement important de lire TOUS les renseignements et TOUTES les directives de sécurité contenues dans ce guide ainsi que toute documentation jointe. Tenir compte de tous les avertissements et suivre toutes les précautions pendant l'installation et l'utilisation de cet appareil.

Les symboles de sécurité utilisés dans ce guide sont les suivants :



**ATTENTION** Ce symbole annonce que l'appareil risque d'être endommagé.



**AVERTISSEMENT** Ce symbole annonce qu'il y a risque d'accident grave ou même fatal.

CETTE SECTION CONTIENT DES INFORMATIONS GÉNÉRALES POUR SE PROTÉGER CONTRE LES DÉCHARGES ÉLECTRIQUES, LES INCENDIES, L'EXPOSITION EXCESSIVE AUX RAYONS UV ET TOUT AUTRE ACCIDENT POUVANT ENTRAÎNER DES BLESSURES.

### **AVERTISSEMENT:**

#### **DIRECTIVES POUR SE PROTÉGER CONTRE LES INCENDIES**

1. Les luminaires VARI\*LITE® ont été conçus pour être utilisés uniquement avec certaines type de lampes. Vérifier le type de lampe (LED) avant de remplacer les lampes. L'installation d'un autre type de lampe peut poser un danger.
2. Les luminaires peuvent être fixés sur tout type de surface tant que les directives de montage sont respectées. Voir les explications détaillées dans ce guide.
3. Vérifier la distance à respecter entre les matériaux combustibles ou les objets illuminés et les luminaires VARI\*LITE®.

### **AVERTISSEMENT:**

#### **DIRECTIVES POUR SE PROTÉGER CONTRE LES DÉCHARGES ÉLECTRIQUES**

1. Les luminaires VARI\*LITE® sont conçus pour une utilisation au sec uniquement. Une exposition à la pluie et à l'humidité risque d'endommager le luminaire.
2. Débrancher l'appareil avant de procéder à la révision de tout matériel VARI\*LITE®.
3. Les révisions doivent être effectuées uniquement par des personnes qualifiées.

**AVERTISSEMENT:**

**DIRECTIVES POUR SE PROTÉGER CONTRE UNE EXPOSITION EXCESSIVE AUX RAYONS UV**

1. Plusieurs luminaires VARI\*LITE® utilisent une lampe qui produit des rayons UV. NE PAS fixer son regard sur la lampe.
2. L'utilisation des luminaires sans lentille ou blindage pose des risques. Tous blindages, lentilles ou écrans ultraviolet visiblement endommagés au point que leur efficacité en est affectée doivent être remplacés, par exemple s'il y a des fissures ou de profondes rayures.

**AVERTISSEMENT:**

**DIRECTIVES POUR SE PROTÉGER CONTRE LES ACCIDENTS POUVANT ENTRAÎNER DES BLESSURES**

1. Les surfaces externes du luminaire deviennent brûlantes quand l'appareil est en marche. Pour manœuvrer ou ajuster des appareils brûlants et leurs composants, se protéger suffisamment (gants, protection pour les yeux, etc.).
2. La lampe du luminaire est brûlante lorsqu'il est en marche. Débrancher le courant et attendre que la lampe ait refroidi avant de la remplacer.
3. Les lampes à arc émettent des rayons ultraviolets pouvant causer de graves brûlures sur la peau et une inflammation des yeux. De plus, les lampes à arc fonctionnent sous haute tension à de très hautes températures. Si la lampe se casse, les particules de la lampe cassée peuvent causer blessures et/ou incendie en s'éparpillant.
4. Se protéger les yeux pour remplacer la lampe.
5. Utiliser des appareils de protection appropriés (gants, protection des yeux) pour manier des lampes endommagées.
6. Si la lampe a été touchée avec des mains nues, la nettoyer avec de l'alcool dénaturé et l'essuyer avec un chiffon non-pelucheux avant d'installer ou de brancher le luminaire.
7. Si la lampe a été endommagée ou a reçu une déformation thermique, elle doit être remplacée.

**AVERTISSEMENT:**

**INTERFÉRENCE RF**

1. Cet appareil est de Classe A. Dans un environnement domestique, cet appareil peut causer des interférences radio, et si c'est le cas, l'utilisateur peut avoir à prendre des mesures adéquates.

**CONSIDÉRATIONS DES CARACTÉRISTIQUES DE LAMPES À ARC**

1. Après une interruption de courant ou une baisse importante de voltage, les lampes à arc mettent du temps avant de se rallumer. Dans certains cas, la lampe se rallumera automatiquement après s'être refroidie. Cela dépend de la manière dont le système est réglé pour le statut de mise en marche de la lampe.
2. La position Brûler est Universelle.

## Aviso sobre Seguridad

Es muy importante leer TODA la información e instrucciones sobre seguridad que se indica en este manual así como en los documentos adjuntos antes de instalar y operar los productos descritos. Se debe prestar atención a todos los avisos y advertencias durante la instalación y uso de este producto.

Los símbolos de seguridad usados en este manual son los siguientes:



**CUIDADO**, indica posibles daños al producto.



**ADVERTENCIA**, indica posibles lesiones o muerte a las personas.

LA INFORMACIÓN GENERAL RELACIONADA A LA PROTECCIÓN CONTRAGOLPES DE CORRIENTE ELÉCTRICA, INCENDIO, EXPOSICIÓN EXCESIVA A RADIACIÓN ULTRA VIOLETA Y LESIONES A LAS PERSONAS SE PUEDE ENCONTRAR SEGUIDAMENTE:

### **ADVERTENCIA:**

#### **INSTRUCCIONES PARA PROTECCIÓN CONTINUA CONTRA INCENDIO**

1. Las luminarias VARI\*LITE® han sido diseñadas para ser usadas solamente con algunas lámparas. Tome nota del tipo de lámpara (LED) antes de reemplazarla. Instalación de otro tipo de lámpara puede ser peligroso.
2. Las luminarias se pueden instalar en cualquier tipo de superficie siempre que se sigan las instrucciones de instalación. Vea las instrucciones detalladas en este manual.
3. Tome nota de los requerimientos de distancia de materiales combustibles u objetos iluminados para las luminarias VARI\*LITE®.

### **ADVERTENCIA:**

#### **INSTRUCCIONES PARA PROTECCIÓN CONTINUA CONTRA CHOQUE ELÉCTRICO**

1. Las luminarias VARI\*LITE® están diseñadas solamente para lugares secos. La exposición a la lluvia o humedad pueden dañar la luminaria.
2. Desconecte la energía antes de dar servicio a cualquier equipo de VARI\*LITE®.
3. El servicio debe ser realizado solamente por personal calificado.

**ADVERTENCIA:**

**INSTRUCCIONES PARA PROTECCIÓN CONTINUA CONTRA LA EXPOSICIÓN EXCESIVA DE RADIACIÓN ULTRA VIOLETA**

1. Muchas luminarias VARI\*LITE® usan un tipo de lámpara que produce radiación UV. NO mire directamente a la lámpara.
2. Es peligroso operar luminarias sin lentes o protectores. Debe cambiar los protectores, lentes o pantallas ultravioletas si se aprecia que han sido dañadas, y que su efectividad pudiera estar deteriorada. Por ejemplo, si tuvieran rajaduras o raspaduras profundas.

**ADVERTENCIA:**

**INSTRUCCIONES PARA PROTECCIÓN CONTRA LESIONES DE PERSONAS**

1. Las superficies exteriores de las luminarias están calientes durante su operación. Use un equipo de seguridad apropiado (guantes, protección para los ojos, etc.) cuando haga ajustes en el equipo y componentes que están calientes.
2. Cuando las luminarias están en operación la lámpara estará muy caliente. Desconecte la energía y deje que la lámpara se enfríe antes de reemplazarla.
3. Las lámparas de arco emiten radiaciones ultravioletas que pueden ocasionar serias quemaduras a la piel e inflamación a los ojos. Además, las lámparas de arco operan a alta presión y muy alta temperatura. Si la lámpara se rompe, puede existir el peligro de lesiones al personal o un incendio ocasionado por las partículas de la lámpara rota que se caen.
4. Use protección para los ojos cuando vuelve a colocar una lámpara nueva.
5. Use un equipo de seguridad apropiado (guantes, protección para los ojos, etc.) cuando trabaje con lámparas dañadas.
6. Si toca la lámpara con las manos, limpie la lámpara con alcohol desnaturalizado y con tela sin pelusas antes de instalar o volver a conectar la luminaria.
7. Cambie la lámpara si está dañada o deformada termicamente.

**ADVERTENCIA:**

**INTERFERENCIA RF**

1. Este es un producto de Clase A. En el ambiente de la casa este producto puede ocasionar radiointerferencia, en cuyo caso, el usuario debe tomar las medidas adecuadas.

**CONSIDERACIONES SOBRE LAS CARACTERÍSTICAS DE LA LÁMPARA DE ARCO**

1. Las lámparas de arco requieren un período de tiempo para volver a iluminarse después de una interrupción de energía o de una severa caída de voltaje. En algunos casos, la lámpara se volverá a iluminar en forma automática después que se ha enfriado dependiendo de la configuración del sistema de energía de la lámpara.
2. La posición de encendido es universal.

## 安全性に関する注意事項

ここに記載されている製品を取り扱う場合は、まず本マニュアルおよび付属のマニュアルの安全性に関する情報と説明をすべてお読みください。また、実際に本製品を取り付けたり使用する際には、すべての注意事項および警告に留意して作業してください。

本マニュアルでは、以下の安全マークを使用しています。



注意：製品に損傷を与える危険性があります。



警告：人身事故につながる危険性があります。

感電、火災、UV放射に対する過度の露出、および人身事故を防ぐための一般的な情報については、以下の説明をお読みください。

警告：

火災の発生を防ぐためのヒント

1. VARI\*LITE® 照明器具は、ランプを使用するように設計されています。ランプを交換する際は、ランプの種類（など）を確認するようにしてください。他の種類のランプを取り付けると危険です。
2. 照明器具は、本マニュアルの指示に従って操作するかぎり、どのようなタイプの表面にでも取り付けることができます。詳細については、本マニュアルを参照してください。
3. ヒューズを交換する場合は、同じヒューズ（同じ種類、同じクラス）を使用してください。
4. VARI\*LITE® 照明器具は、可燃性物質または他の光源から必要な距離だけ離して配置してください。

警告：

感電を防ぐためのヒント

1. VARI\*LITE® 照明器具は、乾燥した環境で使用するよう設計されています。雨で濡れる場所や湿気の多い場所に取り付けると、照明器具が傷むことがあります。
2. VARI\*LITE® 照明器具を修理点検する場合は、必ず先に電源を切ってください。
3. 照明器具の修理点検は、資格を持つ技師のみが行うようにしてください。

**警告：**

過度の UV 放射にさらされないためのヒント

1. VARI\*LITE® 照明器具の多くは、UV 放射を生ずる HID タイプのランプを使用しています。ランプを直視することは避けてください。
2. レンズまたはシールドを使わずに照明器具を点灯すると危険です。レンズ、シールド、紫外線画面は、ひび割れや深い引っかき傷などにより、その効力が損なわれるようになったら取り替えるようにします。

**警告：**

人身事故を防ぐためのヒント

1. 照明器具が点灯しているときは、その外側が熱くなります。熱くなった器具やコンポーネントを取り扱う際には、適切な防具（手袋や保護用眼鏡）を使用してください。
2. 照明器具が点灯しているときは、そのランプが熱くなります。ランプを交換する場合は、照明器具の電源を切り、ランプの温度が下がるまで待ってください。ランプの裏ぶたをあけると、遮断スイッチが働いて、ランプの電源が切れる場合があります。
3. アーク灯は紫外線を放射します。この紫外線によって、ひどい火傷を負ったり、目の炎症を起こすことがあります。さらに、アーク灯は、高圧高温の状態ですべて光を放射します。そのため、万一アーク灯が破損すると、飛び散った破片で人身事故や火災が発生する危険性があります。
4. 再点灯するときには、保護用眼鏡を着用してください。
5. 損傷したランプを取り扱う場合は、適切な防具（手袋や保護用眼鏡）を着用してください。
6. 手袋を着用せずに直接手でランプを触った場合は、変性アルコールを使ってランプをきれいにし、糸くずの出ない布で拭いてから照明器具を取り付け、電源を入れるようにします。
7. 傷がついたランプや熱によって変形したランプは取り替えてください。

**警告：**

**RF 干渉**

1. 本製品は Class A に分類されます。本製品は、家庭環境において無線干渉を起こす可能性があります。その場合、使用者は適切な処置を取らなければならないことがあります。

**アーク灯の特性**

1. 停電後または大きな電圧ディップ後にアーク灯を再点灯する場合は、しばらく時間をおくようにしてください。Lamp Power-Up State) システム設定によっては、温度が下がったときに自動的に再点灯される場合もあります。
2. アーク灯は点光源です。

# Table of Contents

## Introduction

About This Manual .....	1
Additional Documentation .....	1
Text Conventions .....	2
Customer Service .....	2

## Chapter 1. Description

### Features

Standard Features .....	4
-------------------------	---

### Components

Included Items .....	5
Replacement Items/Accessories .....	5
Luminaire Overview .....	6

## Chapter 2. Installation

### Power and Data Cabling Requirements

AC Power .....	10
Current vs. Voltage .....	11
Data Cables .....	12
Recommended Cable Types/Manufacturers .....	13
Male Termination Connector .....	13

### Installation Procedures

Hanging the Luminaire .....	14
Floor Mounting the Luminaire .....	17
Connecting Data and Power .....	17

### Powering Up

Power Up and Configuration Procedure .....	18
--	----

### Addressing

Program Starting Address .....	19
--------------------------------	----

## Chapter 3. Operation

### DMX Operation

Channel Mapping .....	22
Control Channel Functions .....	24

### DMX Mapping

Color & Intensity Control .....	25
Color Mixing .....	25
LED Intensity Control .....	26
Color Time Control .....	26
Beam Control .....	27

Strobe.....	27
Beam Spreader.....	27
Focus Time .....	27
Beam Time .....	27
Luminaire Movement.....	28
Luminaire Pan .....	28
Luminaire Tilt.....	28
<b>Luminaire Timing</b>	
Timing Channel Information.....	29
<b>Updating Software</b>	
USB Download and Programming .....	38
Transferring Software From Luminaire to Luminaire .....	39

## **Chapter 4. Menu System**

<b>Menu Operation</b>	
What Is the Menu System? .....	42
Controls Operation.....	42
Default State .....	44
<b>Menu Functions</b>	
Menu System Overview.....	45
Menu System Function Chart .....	46
Menu Function Definitions .....	48

## **Appendix A. Troubleshooting and Maintenance**

<b>Troubleshooting</b>	
Error Messages.....	52
Troubleshooting Guide.....	53
<b>Routine Maintenance</b>	
Introduction.....	54
Special Cleaning and Care Instructions .....	54
Front Lens Removal and Cleaning.....	55
Beam Spreader Removal for Fixed Beam Applications .....	59

## **Appendix B. Technical Specifications**

VLX™ Wash Luminaire .....	63
---------------------------	----



# Introduction

---

## About This Manual

This manual provides necessary information regarding safety, installation, operation and routine maintenance for the VARI\***LITE**® VLX™ Wash Luminaire. Familiarizing yourself with this information will help you to get the most out of your luminaire.



---

**WARNING:** It is important to read ALL accompanying safety and installation instructions to avoid damage to the product and potential injury to yourself or others.

---

This manual covers the following models:

Model	Part Number	Source
VLX™ Wash Luminaire	20.9690.0001	Seven x 90W RGBW LEDs
VLX™ Wash Luminaire, White	20.9690.0001.02	Seven x 90W RGBW LEDs

---

## Additional Documentation

A service manual, for Authorized VARI\***LITE**® Service Centers and technicians, of the VLX™ Wash Luminaire is available in electronic (PDF) format:

- VLX™ Wash Luminaire Service Manual (02.9690.0010)  
- Testing, Troubleshooting, Component Replacement and Illustrated Parts Breakdown.



---

**Note:** Performing maintenance procedures may void the product warranty. Refer to the Vari-Lite Limited Warranty card included in the product shipping package for more information.

---



---

**Note:** The VLX™ Wash Luminaire requires very little routine maintenance, but has special cleaning instructions unlike other fixtures. Please refer to [“Special Cleaning and Care Instructions”](#) on page 54 for complete cleaning and handling requirements.

---

For more information regarding DMX512 systems, refer to the following document available from United States Institute for Theatre Technology, Inc. (USITT):

- Digital Data Transmission Standard for Dimmers & Controllers plus AMX 192 Analog Multiplex Data Transmission Standard for Dimmers & Controllers. (A copy of Recommended Practice for DMX512 is included.)

USITT Inc.  
6443 Ridings Road  
Syracuse, New York 13206-1111 USA  
Tel: (800) 938-7488 Fax: (866) 398-7488 / [www.usitt.org](http://www.usitt.org)

---

## Text Conventions

The following styles and meanings are used throughout this manual:

Style	Meaning
[Button]	Front panel button. Example: Press [Enter] or [ESC] (Escape).
[Up] / [Down] / [Left] / [Right] Arrows	Press either [Up] or [Down] or [Left] or [Right] arrow button at Menu Display.
MENU	LCD Menu Display read-out. Example: Press [Up] / [Down] / [Left] / [Right] arrows until LAMP appears.

---

## Customer Service

### Our Goal

At Vari-Lite, we are committed to providing you the highest quality in customer service. Our comprehensive resources are available to help your business succeed and ensure you get the full benefit of being a Vari-Lite customer. Whether your needs are telephone troubleshooting assistance, product training or technical service, our full-time staff of experienced professionals are on-hand to provide support.

### How to Reach Us

For assistance in your area, call the dealer from which your product was purchased. *or* Contact an Authorized VARI\*LITE® Service Center *or* Contact the Vari-Lite Customer Service Department, 9am - 6pm CST Monday through Friday, at the following:

phone: 1-877-VARI-LITE (1-877-827-4548) or +1-214-647-7880

email: [customerservice@genlytecontrols.com](mailto:customerservice@genlytecontrols.com)

### Additional Resources

For additional resources and documentation, please visit our website at [www.vari-lite.com](http://www.vari-lite.com) and follow the Support link.



## ***CHAPTER 1.***

# Description

This chapter contains descriptions of luminaire features and components, along with a list of accessories that are available.

- **Features**
- **Components**

# Features

---

## Standard Features

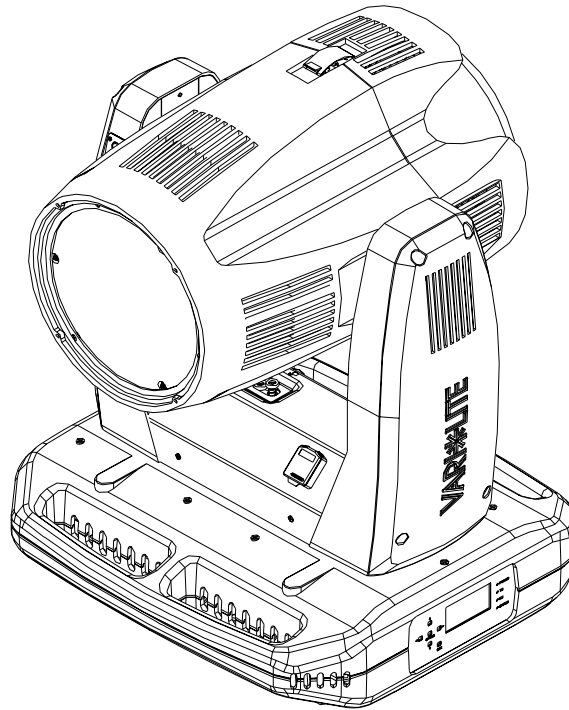

All VLX™ Wash Luminaires have the following standard features:

- Seven, 90-watt RGBW CBM380 LED chipsets.\* Each chip set contains high density red, green, blue, and white LED emitters.
- Manufacturer rated life (LED chip sets), in excess of 50,000 hours (L10-70%).
- Light output exceeds 10,000 lumens.
- Patented optical zoom system with continuous variable field angle from approximately 23° to 60°.
- Zoom module is easily removable for a fixed field angle of 22°.
- High-speed strobe with multi user-selectable effects.
- Smooth pan and tilt operation through time-controlled continuous motion by way of a pair of three-phase stepper motor systems.
- 540° Pan and 270° Tilt with 0.3° resolution.

\* = CBM-380 LED chip set by Luminus Devices, Inc.

# Components

## Included Items

The following illustration shows all items included with the luminaire:

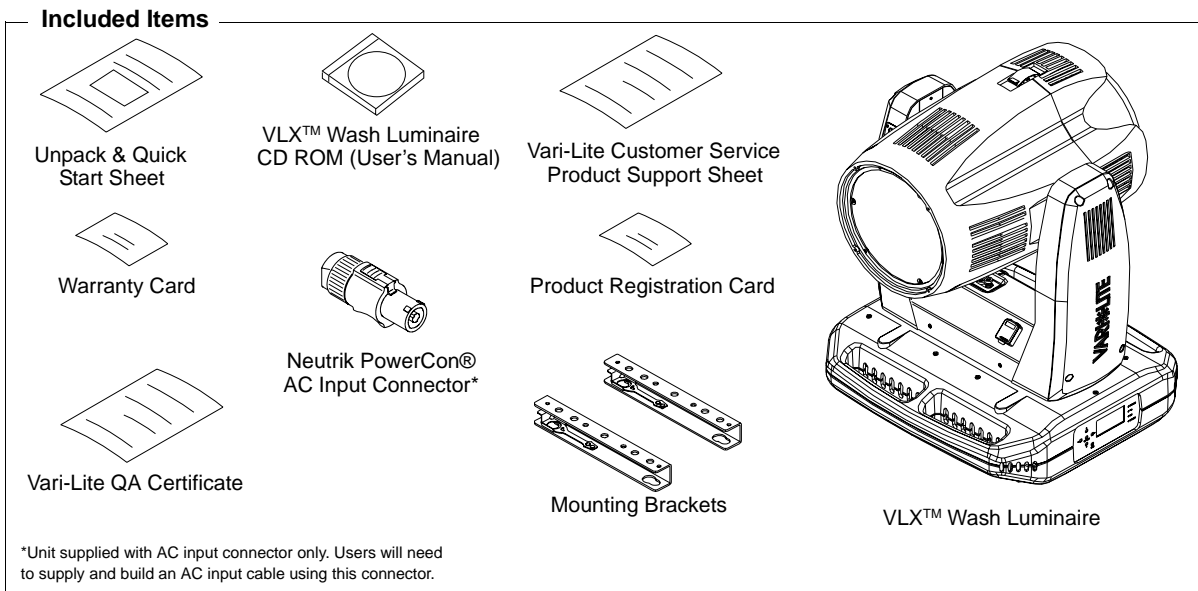

**Figure 1-1: VLX™ Wash Luminaire Packing List**

## Replacement Items/Accessories

The following optional and/or replacement items can be ordered directly from your Authorized VARI\***LITE**® Dealer. (Please order by Vari-Lite part number.)

Vari-Lite P/N	Accessory
22.9620.0194	Safety Cable Assembly
23.9623.0177	XLR DMX Terminator
28.8500.0054	USB Luminaire Programming Kit (Includes USB Upload Cable, Programming Kit CD ROM, Carry Bag, and Instructions)*
55.6840.0001	Truss Hook, Mega-Clamp, Round and Square
55.6841.0001	Truss Hook, Mega-Claw for 2" Round Tube

**Note:** \* For more information on the USB Luminaire Programming Kit, please see [“USB Download and Programming”](#) on page 38.

## Luminaire Overview

The following illustration shows the external luminaire components and controls.

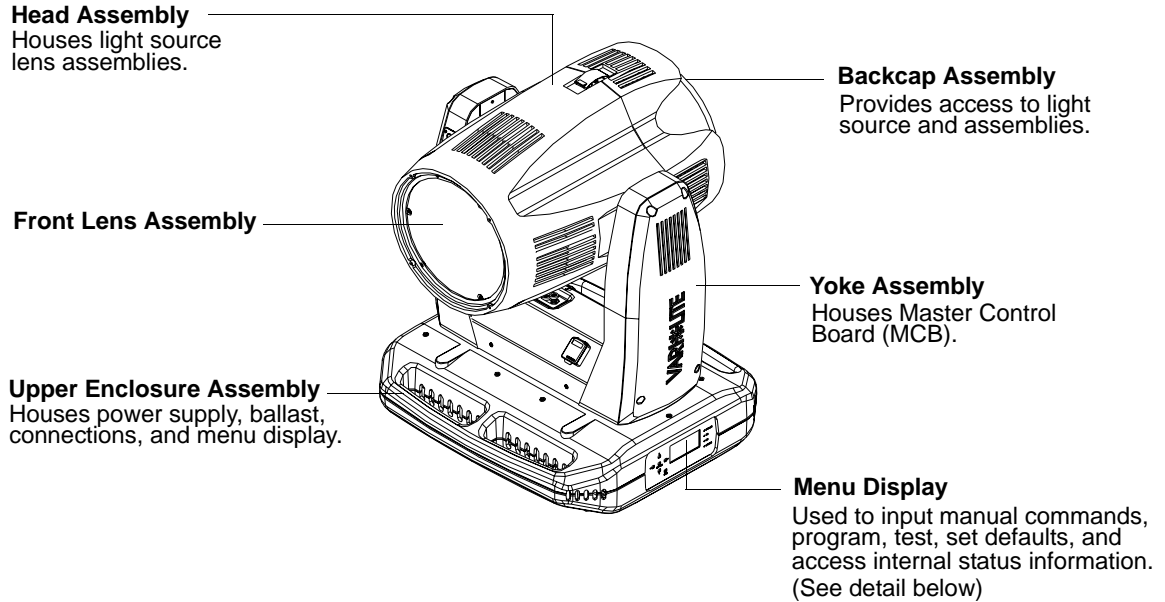

### Pan & Tilt Lock Operation

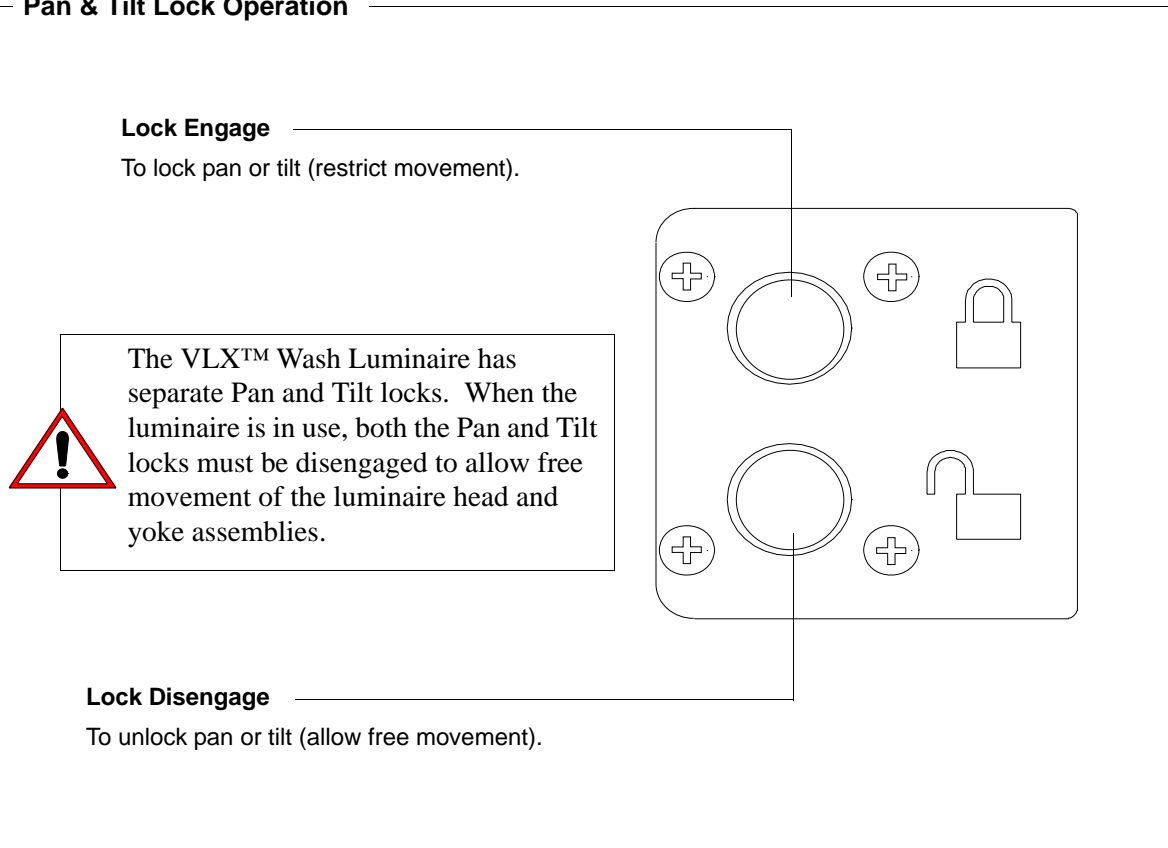
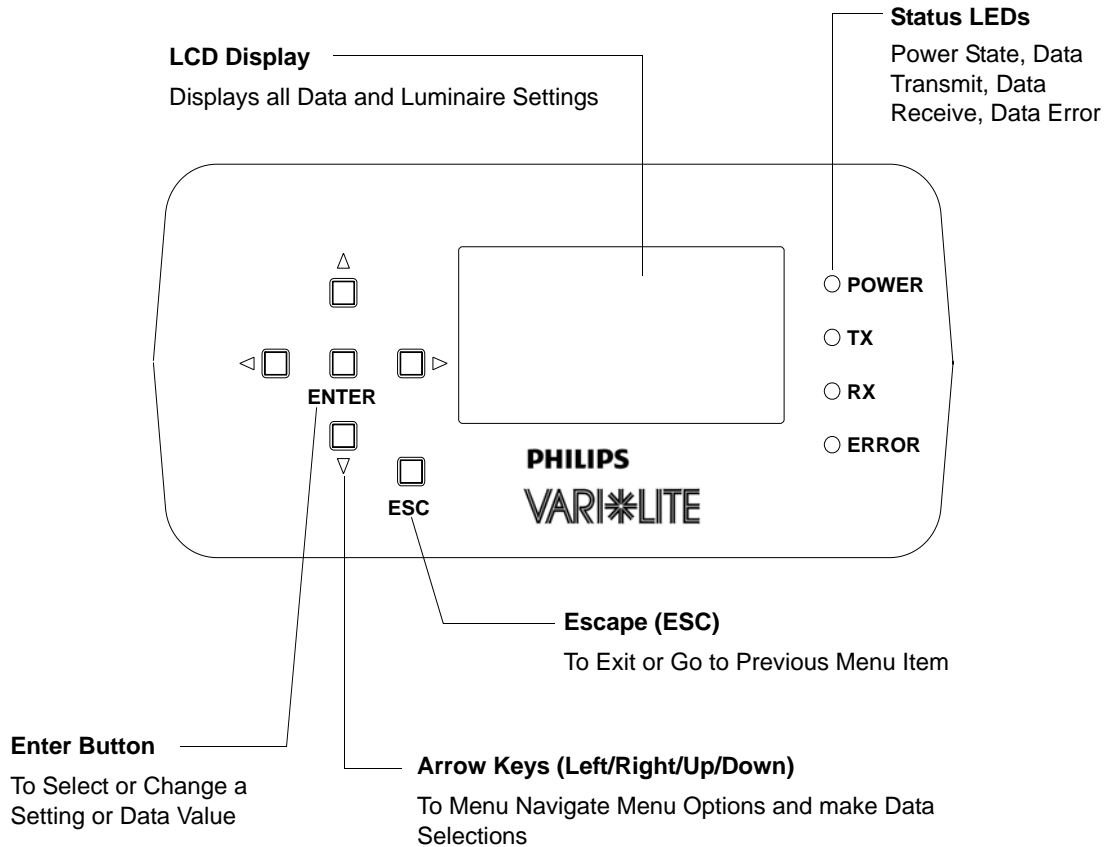

Figure 1-2: VLX™ Wash Luminaire External Components and Controls

## Luminaire Overview (continued)

### Upper Enclosure Menu



### Upper Enclosure Connections

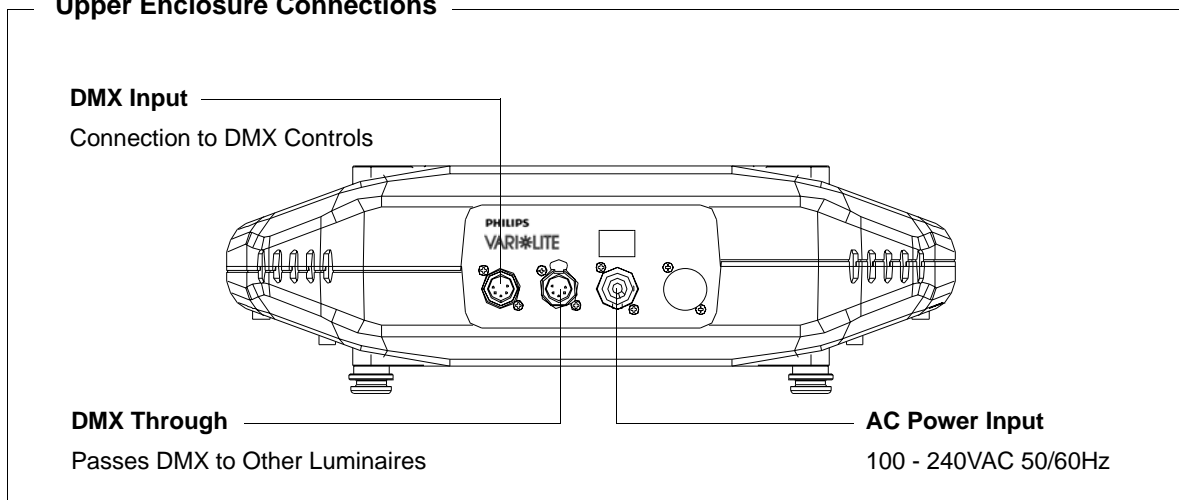

Figure 1-3: VLX™ Wash Luminaire External Components and Controls

---

Notes





## **CHAPTER 2.**

# Installation

This chapter contains instructions for installation of the luminaire. It includes connecting power and data, along with instructions for powering up the luminaire for the first time and addressing it within your system.

- **Power and Data Cabling Requirements**
- **Installation Procedures**
- **Powering Up**
- **Addressing**



---

---

**WARNING:** DO NOT connect or disconnect energized power cable at fixture (under load). Turn off circuit breaker (or completely de-energize circuit) before connecting or disconnecting power cable at fixture. Power is only removed from the fixture by disconnecting power cable from source or turning off source circuit breaker.

---

---

# Power and Data Cabling Requirements

---

## AC Power

---



**WARNING:** DO NOT connect to three-phase Delta service in countries with 240 volt power.

---



**WARNING:** DO NOT connect or disconnect energized power cable at fixture (under load). Turn off circuit breaker (or completely de-energize circuit) before connecting or disconnecting power cable at fixture. Power is only removed from the fixture by disconnecting power cable from source or turning off source circuit breaker.

---

The luminaire requires standard AC power distribution from 100-240 VAC, 50/60 Hz in order to power all internal electronics and motors. It is equipped with a 3-pole Neutrik® PowerCon® locking connector (with contacts for line, neutral, and pre-mating safety grounds) for the purpose of AC input.

Wire*	Connection
Green/Yellow	AC Ground
Blue	AC Neutral
Brown	AC Line

\*International (Harmonized) Standard



**Note:** The mating Neutrik PowerCon® connector is supplied, however, you will need to purchase or construct a cable appropriate for your application.

---

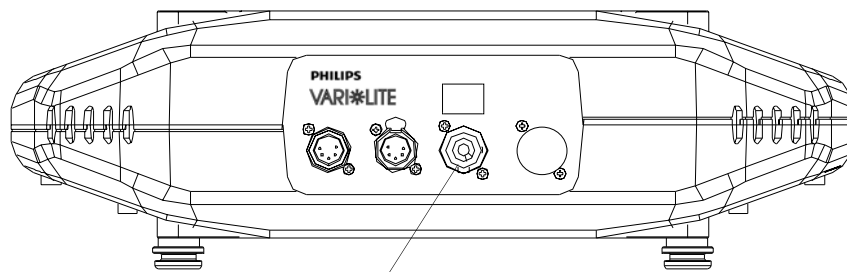

3-Pole Neutrik PowerCon Locking Connector for AC Input Power

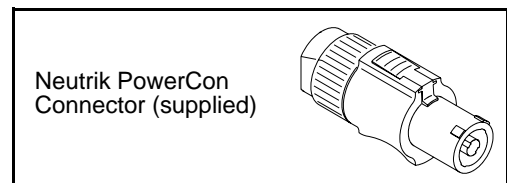

**Figure 2-1: Power Connector**

Current vs. Voltage

The following tables provide the luminaire's current draw at specific voltages.

**Table 2-1: VLX Wash Luminaire - Current vs. Voltage\***

<b>Voltage (VAC) @ 60Hz</b>	<b>Current (A)</b>
100	9.0
110	8.2
120	7.5
130	6.9
140	6.4
150	6.0
160	5.6
170	5.3
180	5.0
190	4.7
200	4.5
210	4.3
220	4.1
230	3.9
240	3.8

\*Currents given are worst case with all motors sequencing.

## Data Cables

The VLX™ Wash Luminaire is equipped with two, 5-pin XLR connectors for DATA IN and DATA THRU (out) applications. DATA IN requires a 5-pin, female XLR connector and DATA THRU requires a 5-pin, male XLR connector. When purchasing or constructing data cables, it is important that not only the correct cable type be used, but also quality cable to ensure a reliable DMX512 system. Your cabling should meet the following USITT DMX specification requirements:

- Suitable for use with EIA485 (RS485) operation at 250k baud.
- Characteristic impedance 85-150 ohms, nominally 120 ohms.
- Low capacitance.
- Two twisted pairs.
- Foil and braid shielded.
- 24 AWG minimum gauge for runs up to 1000 feet (300m).
- 22 AWG minimum gauge for runs up to 1640 feet (500m).



**Note:** Microphone type cables and other general purpose, two-core audio or signal cables are not suitable for use with DMX512.

The XLR 5-pin connectors should be wired as follows:

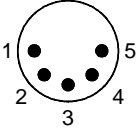
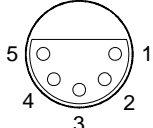
Pin/Wire Code to XLR Connectors						
Data Thru Cable Pinout   Male Conn	<b>Pin 1</b>  Foil & Braided Shield	<b>Pin 2</b>  1st conductor of 1st twisted pair  Data (-)	<b>Pin 3</b>  2nd conductor of 1st twisted pair  Data (+)	<b>Pin 4</b>  1st conductor of 2nd twisted pair  Data (-)	<b>Pin 5</b>  2nd conductor of 2nd twisted pair  Data (+)	Data In Cable Pinout   Female Conn



**Note:** Refer to the USITT Recommended Practice for DMX512 guide for additional information regarding DMX512 systems. How to obtain a copy is detailed in [“Additional Documentation” on page 1.](#)

## Recommended Cable Types/Manufacturers

These are only a few of the suitable cable types. Any quality EIA485, twisted pair, 120 ohm, shielded cable will also work.

**Table 2-2: Recommended Cable Types**

Type	Pairs	ZΩ*	Jacket	AWG	Use	Temp (F)
Belden Cables						
1215A	2	150	PVC	26	IBM Type 6 Office cable	75
1269A	2	100	PTFE	22 (Solid)	High Temp, Plenum cable	200
8102	2	100	PVC	24	UL2919	80
8132	2	120	PVC	28	UL2919	80
8162	2	100	PVC	24	UL2493	60
82729	2	100	PTFE	24	High Temp, Plenum cable	200
88102	2	100	PTFE	24	High Temp, Plenum cable	200
89696	2	100	PTFE	22	High Temp, Plenum cable	200
89729	2	100	PTFE	24	High Temp, Plenum cable	200
89855	2	100	PTFE	22	High Temp, Plenum cable	200
9729	2	100	PVC	24	UL2493	60
9804	2	100	PVC	28	UL2960	60
9829	2	100	PVC	24	UL2919	80
9842	2	120	PVC	24	UL2919	80
Proplex Cables						
PC224P	2	110	Polyurethane	22	Heavy Duty and Portable	105
PC224T	2	110	PVC	22	UL2464	105
PC226T	3	110	PVC	22	UL2464	

\* Characteristic Impedance

## Male Termination Connector

A male XLR termination connector is required at the last luminaire (or “far end of the line”) to prevent signal reflections. Signal reflections may cancel out the signal at certain line lengths, resulting in errors. The terminator is also necessary for software downloads and running tests on multiple luminaires. To construct your own connector, you will need the following components:

- 5-pin, male XLR connector.
- Two 1/4W 5% 120 ohm resistors.

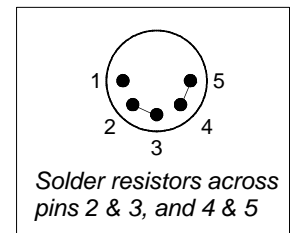

**Note:** A male termination connector is also available as an accessory from Vari-Lite. See “Replacement Items/Accessories” on page 5.

# Installation Procedures

## Hanging the Luminaire

The VLX™ Wash Luminaire can be hung horizontally or vertically from any structure designed to work with the type of load created by this moving luminaire. Two mounting bracket assemblies (provided) are used to attach truss hooks or other mounting hardware as required. Many compatible truss hooks are available from different manufacturers for your particular needs.

A minimum of one hook per truss hook bracket is required. If mounting method does not use truss hooks, two attachment points per truss hook bracket are required. When attaching more than one point on a single bracket, the attach points must be spaced as far apart as possible using the supplied mounting holes.

### Install mounting hardware and brackets:

Step 1. Install truss hooks on two provided truss hook brackets as required.

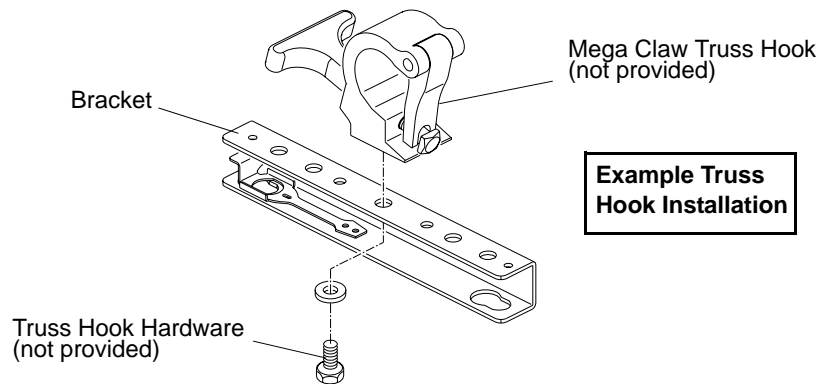

Figure 2-2: Installing Truss Hooks

**Note:** Various types of truss hooks can be used. The Mega Claw truss hook (as shown in the example above) as well as many other standard hooks, can be ordered separately. See [“Replacement Items/Accessories”](#) on page 5.

Step 2. Determine required configuration of bracket installation. Brackets may be installed in either orientation as shown in Figure 2-3, but both must face the same direction. Figure 2-4 shows bracket installation details.

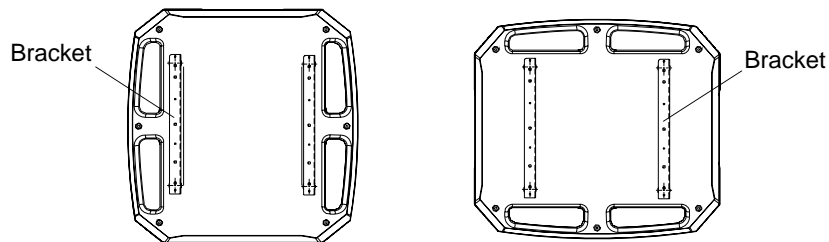

Figure 2-3: Bracket Orientation Options

Step 3. While pulling up on locking mechanism release, fit keyed holes onto raised mounting buttons at bottom of enclosure. Slide forward and release locking mechanism to lock in place. Ensure brackets are locked securely. (Always face brackets in same direction as shown.)



**WARNING:** Ensure that the bracket locking mechanism is fully seated after the bracket is installed on the luminaire.

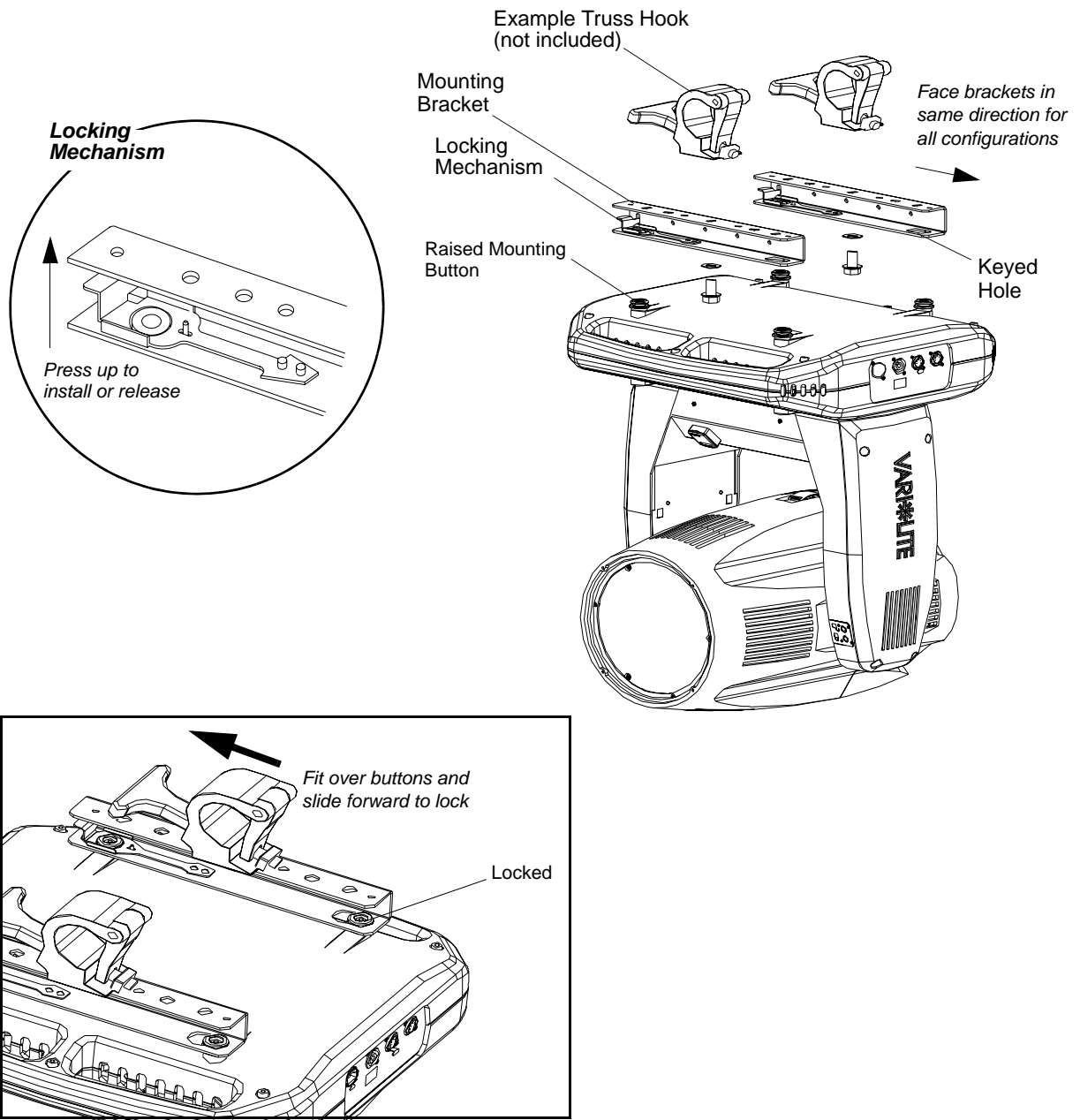

Figure 2-4: Installing Brackets on Luminaire Enclosure

**Installing in Truss:**

- Step 1. Using two people, lift luminaire into mounting position.
- Step 2. Secure in place with truss hook. Ensure truss hook hardware that locks hook in place (e.g. wing bolt) is properly tightened and that luminaire is fully supported.
- Step 3. Attach safety cable (as required) as follows:
  - a. Connect one end of cable to luminaire handle.
  - b. Loop at least once around truss/pipe and attach other end of cable to other handle.
- Step 4. Connect power and data cables according to procedure given in [“Connecting Data and Power”](#) on page 17.



**WARNING:** DO NOT connect or disconnect energized power cable at fixture (under load). Turn off circuit breaker (or completely de-energize circuit) before connecting or disconnecting power cable at fixture. Power is only removed from the fixture by disconnecting power cable from source or turning off source circuit breaker.

- Step 5. Be sure pan and tilt locks are disengaged (refer to [“Luminaire Overview”](#) on page 6 for details) to allow full head and yoke movement.

Use enclosure handles for safety cable anchor points (refer to Top View illustration below).

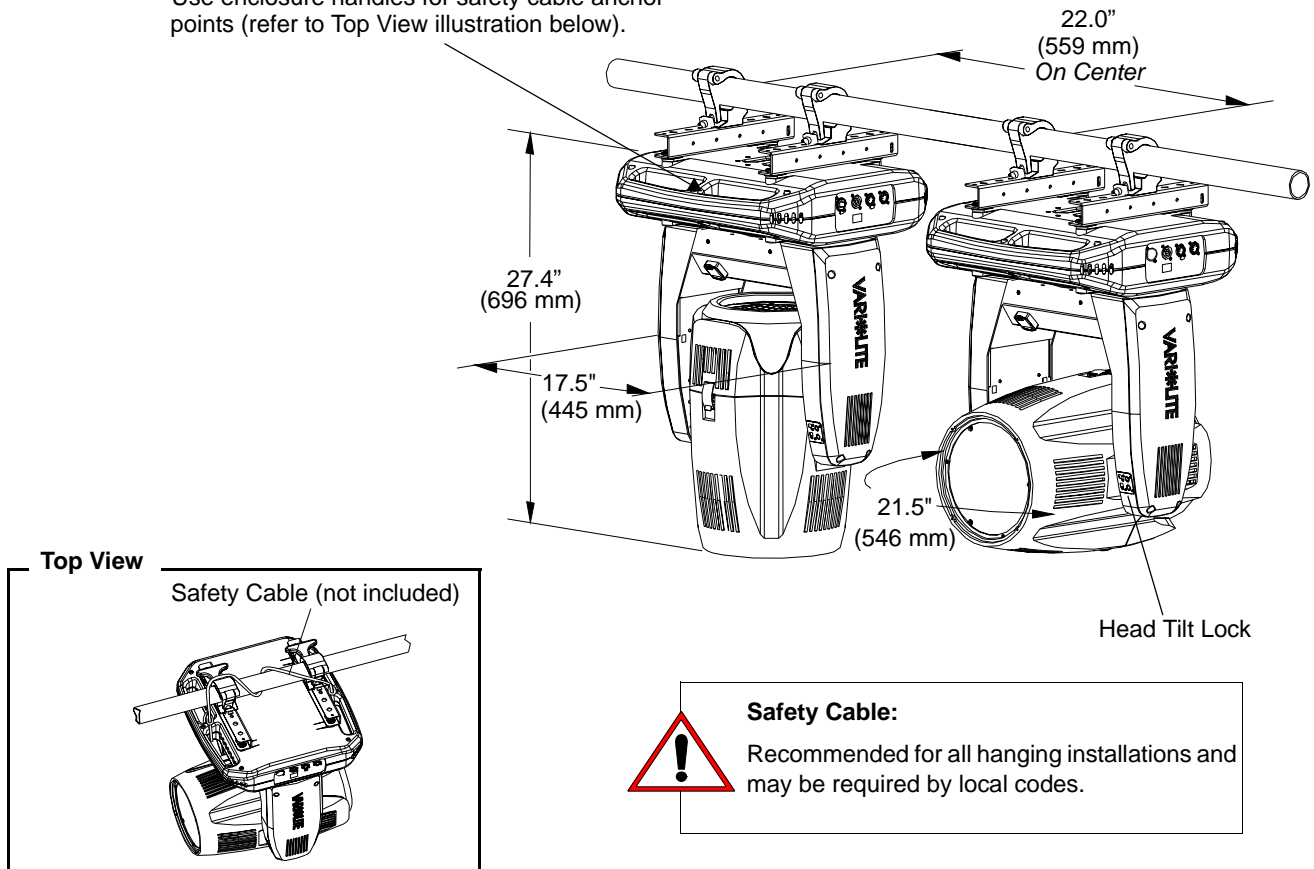
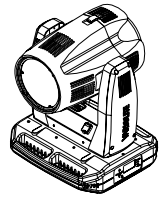

**Figure 2-5: Hanging Configuration and Dimensions**



## Floor Mounting the Luminaire

The luminaire enclosure is sufficient to stabilize the luminaire in a floor installation, provided that the mounting surface is flat and sturdy. Also, the area around the luminaire must be free of debris and moisture.



## Connecting Data and Power

A maximum of 32 luminaires may be connected in any one DMX data link.



**Note:** This maximum limit applies to the luminaire "daisy chain" only. Your system or console may require fewer luminaires on a single data link path. Consult your console documentation for more information.

### To connect power and data:

- Step 1. Connect data cable from console to first luminaire in chain at DATA IN connector.
- Step 2. If required, connect additional data cables from DATA THRU connectors to DATA IN connectors of remaining luminaires in link.
- Step 3. At last luminaire in link, install male termination connector at DATA THRU connector. (Luminaires and other devices on the same DMX chain may not function properly without termination.)
- Step 4. Connect AC input cable connector to fixture before connecting to power input source or energizing power cable.



**WARNING:** DO NOT connect or disconnect energized power cable at fixture (under load). Turn off circuit breaker (or completely de-energize circuit) before connecting or disconnecting power cable at fixture. Power is only removed from the fixture by disconnecting power cable from source or turning off source circuit breaker.

- Step 5. Dress AC input and data cables and secure them so they do not interfere with luminaire head and yoke movement.
- Step 6. Be sure pan and tilt locks are disengaged (refer to [“Luminaire Overview”](#) on page 6 for details) to allow full head and yoke movement.

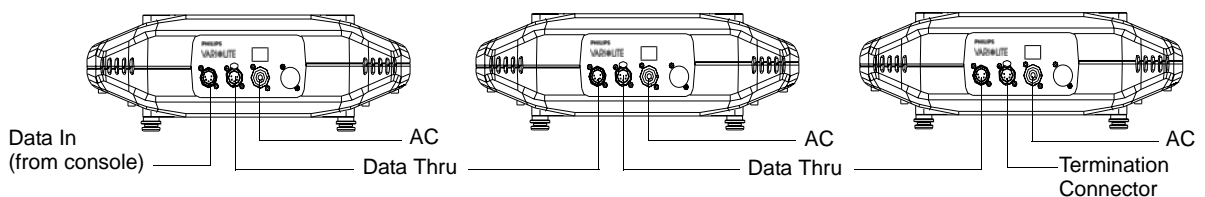

Figure 2-6: Connecting Power and Data

# Powering Up

---

## Power Up and Configuration Procedure

When AC power is initially applied, the luminaire immediately begins a calibration sequence that steps it through pan and tilt movements. The beam mechanism also moves through a full range of motion. After calibration, the luminaire head either stops at its “home” position (which positions the pan axis at mid-rotation and the head parallel to the yoke with the lens pointing away from the luminaire upper enclosure) or it moves to its current DMX-defined position when DMX data is present. All internal mechanisms also move to their “home” or DMX-defined positions.



**CAUTION:** Before applying power, be sure the luminaire is hung or positioned so that the head and yoke can move freely without restriction.

---

### To power up:



**WARNING:** DO NOT connect or disconnect energized power cable at fixture (under load). Turn off circuit breaker (or completely de-energize circuit) before connecting or disconnecting power cable at fixture. Power is only removed from the fixture by disconnecting power cable from source or turning off source circuit breaker.

---

- Step 1. At each luminaire, connect power cable to fixture.
- Step 2. Be sure pan and tilt locks are disengaged (refer to [“Luminaire Overview”](#) on page 6 for details) to allow full head and yoke movement.
- Step 3. Energize each connected circuit.
- Step 4. Luminaire will automatically cycle through calibration and stop at "home" position.

# Addressing

---

## Program Starting Address

The address setting for DMX console controlled systems is entered using the Menu Display (refer to [“Menu Operation” on page 42](#)). The luminaire retains the DMX address even when power is removed.

---

**Note:** Refer to your console operating instructions for specific information regarding its addressing requirements.

---

### **Program a DMX starting address:**

- Step 1. Press [ESC] to access the main menu of the luminaire.
- Step 2. Press [Up] / [Down] arrows until Address appears. Press [Enter].
- Step 3. Press [Up] / [Down] arrows to enter starting address.
- Step 4. Press [Enter] to set.

Notes



## ***CHAPTER 3.***

# Operation

This chapter contains instructions for operating the luminaire using DMX control and for updating the internal software.

- **DMX Operation**
- **DMX Mapping**
- **Luminaire Timing**
- **Updating Software**

# DMX Operation

## Channel Mapping

These tables assume a DMX start address of 1. When a different starting address is used, this address becomes channel 1 function and other functions follow in sequence.

**Table 3-1: VLX™ Wash Luminaire Mapping Mode 1**

DMX Channel	Parameter	Range DMX	Range%	Description
1	Intensity - High	0 - 65535	0 - 100%	16-bit control for Intensity of LED settings.
2	Intensity - Low			
3	Pan - High Byte	0 - 65535	0 - 100%	16-bit control of Pan - 540° of movement (default = 32768).
4	Pan - Low Byte			
5	Tilt - High Byte	0 - 65535	0 - 100%	16-bit control of Tilt - 270° of movement (default = 32768).
6	Tilt - Low Byte			
7	Red - High Byte	0 - 65535	0 - 100%	16-bit control of Red LEDs from 0 to full.
8	Red - Low Byte			
9	Green - High Byte	0 - 65535	0 - 100%	16-bit control of Green LEDs from 0 to full.
10	Green - Low Byte			
11	Blue - High Byte	0 - 65535	0 - 100%	16-bit control of Blue LEDs from 0 to full.
12	Blue - Low Byte			
13	White - High Byte	0 - 65535	0 - 100%	16-bit control of White LEDs from 0 to full.
14	White - Low Byte			
15	Unused	N/A	N/A	For Future Use
16	Unused	N/A	N/A	For Future Use
17	Beam Spreader	0 - 255	0 - 100%	Controls beam angle from 23° to 60° (DMX 255)
18	Strobe	0 - 255	0 - 100%	Controls strobe operations as follows: Open = DMX 0 - 2 Closed = DMX 3 - 5 Slow Rand = DMX 6 - 7 Med Rand = DMX 8 - 10 Fast Rand = DMX 11 - 12 Strobe Range = DMX 13 - 255 (fastest)
19	Unused	N/A	N/A	For Future Use
20	Focus Time	0 - 255	0 - 100%	Allows for luminaire timing of pan and tilt. Profile should default to DMX 255 for smoothest console fade times.
21	Color Time	0 - 255	0 - 100%	Allows for luminaire timing of color mixing. Profile should default to DMX 255 for smoothest console fade times.

*VLX™ Wash Luminaire mapping continued on the next page.*

Table 3-1: VLX™ Wash Luminaire Mapping Mode 1

22	Beam Time	0 - 255	0 - 100%	Allows for luminaire timing of zoom. Profile should default to DMX 255 for smoothest console fade times.
23	Control	0 - 255	0 - 100%	Used to set different modes, parameters, and functions of the VLX luminaire. Set control channel value for desired action. Hold value for at least 3 seconds. Set control channel value to 0 without any scaling. LED CAL ON = DMX 118 - 120 LED CAL OFF = DMX 116 - 117 Full Luminaire Reset = DMX 81 - 87 Default Setting = DMX 0

## Control Channel Functions

Used to set different modes, parameters, and functions of the VLX™ Wash Luminaire. Set control channel value for desired action. Hold value for at least 3 seconds.

Set control channel value to 0 without any scaling. Discrete values must be used; not manual controls such as faders or encoders (see chart below for values).

**Table 3-2: Control Channel Functions**

DMX Channel	Control Channel Function	Control Channel DMX Value
23	Default Setting	0
	Full Luminaire Reset	81 - 87
	LED CAL ON	118 - 120
	LED CAL OFF	116 - 117

**To use control channel functions:**

- Step 1. Select an action to be sent.
- Step 2. Set control channel value for desired action (for example, 84 for reset). Hold value for at least 3 seconds.
- Step 3. Set control channel value to zero. (This must occur without any scaling values. Action will be voided if other values are detected between action value and zero.)



**Note:** A numerical keypad is required for sending values. An encoder or fader does not allow for a quick value change, which is required to effect the control functions. However, the encoders on some consoles include discreet value capability.



# DMX Mapping

---

## Color & Intensity Control

The luminaire's color system is composed of a color mixing seven 90-watt RGBW LEDs. The following sections describe these components.

### Color Mixing

All color mixing is accomplished via the luminaire's seven 90-watt RGBW LEDs using 16-bit control.

**Table 3-3: DMX Map for Color Mixing - Red LEDs**

DMX Channel	% Value	DMX Value	Action
7 (High Byte)	0 - 100	0 - 65535	16-Bit Control of Red LEDs from 0 to Full
8 (Low Byte)			

**Table 3-4: DMX Map for Color Mixing - Green LEDs**

DMX Channel	% Value	DMX Value	Action
9 (High Byte)	0 - 100	0 - 65535	16-Bit Control of Green LEDs from 0 to Full
10 (Low Byte)			

**Table 3-5: DMX Map for Color Mixing - Blue LEDs**

DMX Channel	% Value	DMX Value	Action
11 (High Byte)	0 - 100	0 - 65535	16-Bit Control of Blue LEDs from 0 to Full
12 (Low Byte)			

**Table 3-6: DMX Map for Color Mixing - White LEDs**

DMX Channel	% Value	DMX Value	Action
13 (High Byte)	0 - 100	0 - 65535	16-Bit Control of White LEDs from 0 to Full
14 (Low Byte)			

## LED Intensity Control

Provides 16-bit control of LED intensity settings.

**Table 3-7: DMX Map for LED Intensity**

DMX Channel	% Value	DMX Value	Action
1 (High Byte)	0 - 100	0 - 65535	16-bit control for Intensity of LED settings
2 (Low Byte)			

## Color Time Control

**Table 3-8: DMX Map for Color Time Control**

DMX Channel	% Value	DMX Value	Action
21	0 - 100	0 - 255	Allows for luminaire timing of color mixing. Profile should default to DMX 255 for smoothest console fade times.

---

## Beam Control

### Strobe

**Table 3-9: DMX Map for Strobe**

DMX Channel	% Value	DMX Value	Action
18	0 - 100	0-2	Open
		3-5	Closed
		6-7	Slow Random
		8-10	Medium Random
		11-12	Fast Random
		13 - 255 (fastest)	Strobe Range

### Beam Spreader

**Table 3-10: DMX Map for Beam Spreader**

DMX Channel	% Value	DMX Value	Action
17	0 - 100	0 - 255	Controls Beam Angle from 23 degrees (DMX 0) to 60 degrees (DMX 255)

### Focus Time

**Table 3-11: DMX Map for Focus Timing**

DMX Channel	% Value	DMX Value	Action
20	0 - 100	0 - 255	Allows for luminaire timing of pan and tilt. Profile should default to DMX 255 for smoothest console fade times.

### Beam Time

**Table 3-12: DMX Map for Beam Timing**

DMX Channel	% Value	DMX Value	Action
22	0 - 100	0 - 255	Allows for luminaire timing of zoom. Profile should default to DMX 255 for smoothest console fade times.

## Luminaire Movement

### Luminaire Pan

16-bit control of luminaire pan operation.

**Table 3-13: DMX Map for Luminaire Pan Operation**

DMX Channel	% Value	DMX Value	Action
3 (High Byte)	0 - 100	0 - 65535	16-bit control of Pan - 540 degrees of movement (default = 32768)
4 (Low Byte)			

### Luminaire Tilt

16-bit control of luminaire tilt operation.

**Table 3-14: DMX Map for Luminaire Tilt Operation**

DMX Channel	% Value	DMX Value	Action
5 (High Byte)	0 - 100	0 - 65535	16-bit control of Tilt - 270 degrees of movement (default = 32768)
6 (Low Byte)			

# Luminaire Timing

---

## Timing Channel Information

Timing channel control improves the timed moves of certain groups of parameters. We provide up to four timing channels, one for focus (Pan and Tilt), one for color parameters, one for beam parameters, and one for gobo wheel position (spot version only).

Types of timing control:

- **Timing Control Channel:** the luminaire uses its timing channel value to calculate a smooth continuous movement for a given time and transition.
- **Console Timing:** the console calculates the time duration between the DMX increments to be sent for a given time and transition.

Guidelines:

- Timing channels support time values of up to six minutes.
- To use a timing channel instead of console timing, it is necessary to set the timing channel to the desired value and set cue and/or parameter time to zero. A combination of time controls can produce unexpected results.
- The default value setting in the profile should be 255 (proportional control) to allow smooth movement when using console timing.
- The timing channel data should change as a snap. A zero value will give the fastest move, however, without any smoothing this can appear "steppy" in console timed moves.



---

**Note:** Some parameters have been excluded from the timing channels.

---

**Table 3-15: VLX Channel Function / Timing Channel Relationship**

Channel Function	Timing Channel		
	Focus Time	Color Time	Beam Time
Pan (Hi Byte/Lo Byte)	◆		
Tilt (Hi Byte/Lo Byte)	◆		
Red (Hi Byte/Lo Byte)		◆	
Green (Hi Byte/Lo Byte)		◆	
Blue (Hi Byte/Lo Byte)		◆	
White (Hi Byte/Lo Byte)		◆	
Zoom			◆

A timing value of zero is full speed. A time value of 100% (or 255 in DMX) enables the associated parameter(s) to follow cue fade time (console time) rather than the timing channel.



**Note:** The particular storing syntax for your console, as well as instructions on how to write part cues, can be found in the operation manual for that console.

---

**To use these channels, you must:**

- Step 1. Create the cue, including color, gobo, edge and diffusion as required.
  - Step 2. Decide which fixtures and which parameter groups will use timing channels.
  - Step 3. Assign a value to the particular timing channel(s) you wish to use (for timing information, see chart on next page).
  - Step 4. Set console timing (or cue fade time) for parameters and timing channels to zero seconds.
  - Step 5. Store cue.
- 



**Note:** Avoid changing timing channel values in a fading cue. This can cause unexpected behavior in the luminaire as the timing channel value is updated over time. Timing channel values and the final destination of the parameters affected by the timing channel should always be sent in a zero count.

---

Timing channels can be set in either % or 0-255 (DMX) modes, with the following values assigned:

**Table 3-16: Timing Channels Map**

<b>% Value</b>	<b>DMX</b>	<b>= Seconds</b>
	0	Full Speed
	1	0.2
	2	0.4
1	3	0.6
	4	0.8
2	5	1
	6	1.2
	7	1.4
3	8	1.6
	9	1.8
4	10	2
	11	2.2
	12	2.4
5	13	2.6
	14	2.8
6	15	3
	16	3.2
	17	3.4
7	18	3.6
	19	3.8
8	20	4
	21	4.2
	22	4.4
9	23	4.6
	24	4.8
10	25	5
	26	5.2
	27	5.4
11	28	5.6
	29	5.8
	30	6
12	31	6.2
	32	6.4
13	33	6.6
	34	6.8
	35	7.0
14	36	7.2
	37	7.4
15	38	7.6

Table 3-16: Timing Channels Map (Continued)

% Value	DMX	= Seconds
	39	7.8
	40	8
16	41	8.2
	42	8.4
17	43	8.6
	44	8.8
	45	9
18	46	9.2
	47	9.4
19	48	9.6
	49	9.8
	50	10
20	51	10.2
	52	10.4
	53	10.6
21	54	11
	55	11
22	56	12
	57	12
	58	13
23	59	13
	60	14
24	61	14
	62	14
	63	15
25	64	15
	65	16
26	66	16
	67	16
	68	17
27	69	17
	70	18
28	71	18
	72	18
	73	19
29	74	19
	75	20
30	76	20
	77	20
	78	21
31	79	21
	80	21



Table 3-16: Timing Channels Map (Continued)

% Value	DMX	= Seconds
	81	22
32	82	22
	83	23
33	84	23
	85	23
	86	24
34	87	24
	88	25
35	89	25
	90	25
	91	26
36	92	26
	93	27
37	94	27
	95	27
	96	28
38	97	28
	98	29
39	99	29
	100	29
	101	30
40	102	30
	103	30
	104	31
41	105	31
	106	32
42	107	32
	108	32
	109	33
43	110	33
	111	34
44	112	34
	113	34
	114	35
45	115	35
	116	36
46	117	36
	118	36
	119	37
47	120	37
	121	38
48	122	38

Table 3-16: Timing Channels Map (Continued)

% Value	DMX	= Seconds
	123	38
	124	39
49	125	39
	126	39
	127	40
50	128	40
	129	41
51	130	41
	131	41
	132	42
52	133	42
	134	43
53	135	43
	136	43
	137	44
54	138	44
	139	45
55	140	45
	141	45
	142	46
56	143	46
	144	47
57	145	47
	146	47
	147	48
58	148	48
	149	49
59	150	49
	151	49
	152	50
60	153	50
	154	50
	155	51
61	156	51
	157	52
62	158	52
	159	52
	160	53
63	161	53
	162	54
64	163	54
	164	54

Table 3-16: Timing Channels Map (Continued)

% Value	DMX	= Seconds
	165	55
65	166	55
	167	56
66	168	56
	169	56
	170	57
67	171	57
	172	58
68	173	58
	174	58
	175	59
69	176	59
	177	59
	178	60
70	179	60
	180	65
71	181	65
	182	65
	183	70
72	184	70
	185	75
73	186	75
	187	75
	188	80
74	189	80
	190	85
75	191	85
	192	85
	193	90
76	194	90
	195	95
77	196	95
	197	95
	198	100
78	199	100
	200	110
79	201	110
	202	110
	203	120
80	204	120
	205	120
81	206	130

Table 3-16: Timing Channels Map (Continued)

% Value	DMX	= Seconds
	207	130
	208	140
82	209	140
	210	140
	211	150
83	212	150
	213	160
84	214	160
	215	160
	216	170
85	217	170
	218	180
86	219	180
	220	180
	221	190
87	222	190
	223	200
88	224	200
	225	200
	226	210
89	227	210
	228	210
	229	220
90	230	220
	231	230
91	232	230
	233	230
	234	240
92	235	240
	236	250
93	237	250
	238	250
	239	260
94	240	260
	241	270
95	242	270
	243	270
	244	280
96	245	280
	246	290
97	247	290
	248	290

Table 3-16: Timing Channels Map (Continued)

<b>% Value</b>	<b>DMX</b>	<b>= Seconds</b>
	249	300
98	250	300
	251	310
99	252	310
	253	310
	254	310
100	255	Follows Cue Data

# Updating Software

---

## USB Download and Programming

To download files with a PC equipped with a Universal Serial Bus (USB) port, you need the VARI\*LITE® USB Luminaire Programming Kit (28.8500.0054). The USB Luminaire Programming Kit can be ordered directly from your Authorized VARI\*LITE® Dealer.

The VARI\*LITE® USB Luminaire Programming Kit (28.8500.0054) includes:

- VARI\*LITE® USB Upload Cable (25.9600.0001)
- USB Luminaire Programming Kit CD (87.8500.0002)
- Instruction Sheet (02.8500.0100)
- VARI\*LITE® carry bag (07.5044.0005)

### Computer Requirements for the USB Luminaire Programming Kit

- PC running Windows® 98, 2000, XP, or Vista. Although the USB Luminaire Programming kit software is not directly compatible with Macintosh® computers, it does run with some Windows emulators.
- In addition to Windows, your computer must be running IE 5.01 or later, and Microsoft.NET Framework Version 3.5 (or later), which you can download from <http://www.microsoft.com> and search for .NET Framework downloads.
- An available USB 2.0 port on the PC.

### USB VLDownloader PC Program and .bin Luminaire Files

The USB VLDownloader program and current .bin files are available from the Product Downloads page at [www.vari-lite.com](http://www.vari-lite.com). Instructions for installing the USB VLDownloader program on your PC are also available on the Product Downloads page. Use the USB VLDownloader program to transfer updated versions of the luminaire operating software (.bin files) from your PC to the luminaires.



**Note:** Refer to instruction sheet 02.8500.0100 for detailed programming instructions for VARI\*LITE® luminaires.

---

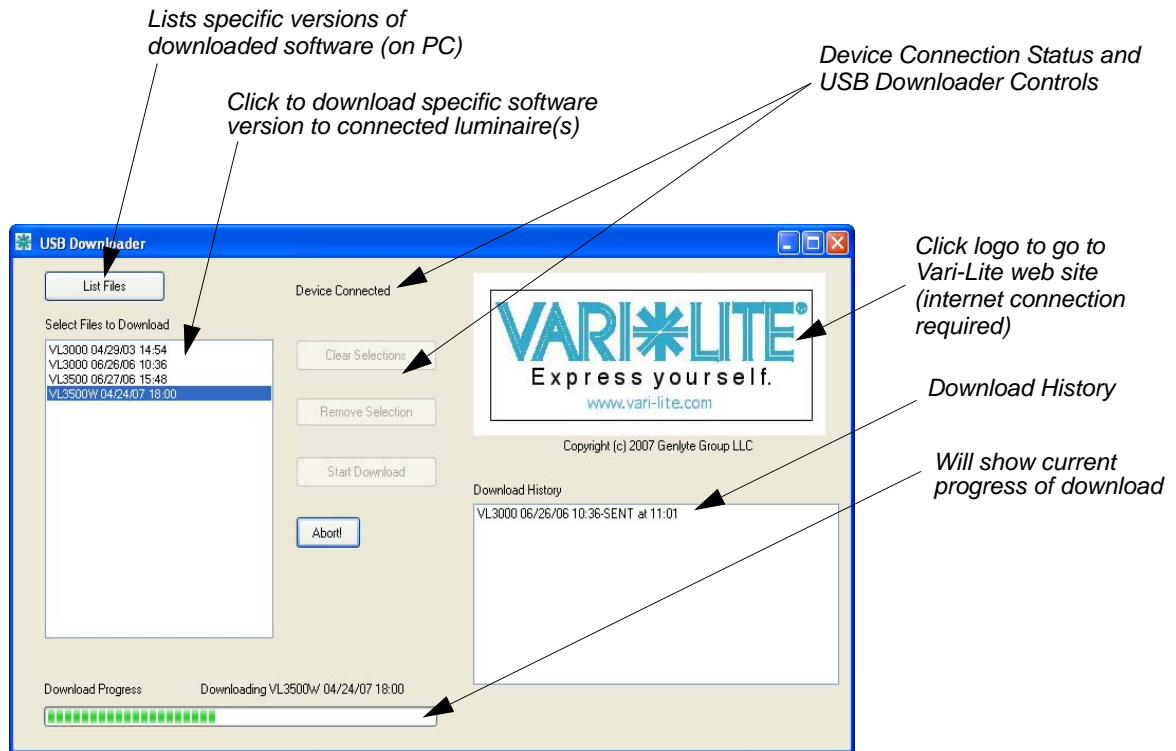

**Figure 3-1: VL Download Program Window**

## Transferring Software From Luminaire to Luminaire

It is possible to transfer specific software versions between luminaires. As in the case of installing new software versions, multiple luminaires can be programmed at the same time when they are data linked together (refer to [“Connecting Data and Power”](#) on page 17), however, only a maximum of 32 luminaires can be updated at once.

### Hardware Requirements

Data cables used in this process must have two twisted pairs and a shield. It is also recommended that cables meet all other USITT DMX specification requirements. Refer to [“Data Cables”](#) on page 12.

A termination connector is used in this process. Refer to [page 13](#) for more information regarding the construction of this connector.

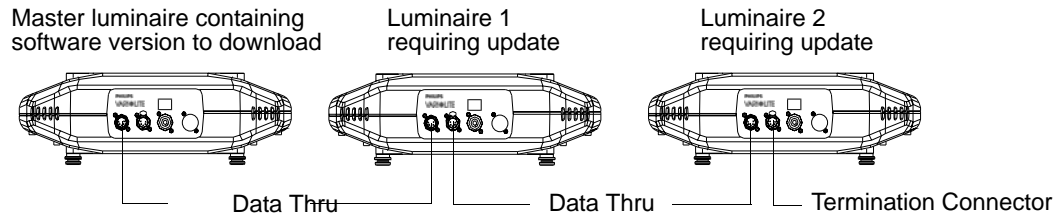

**Figure 3-2: Software Transfer Setup**

### Transfer Procedure

This procedure is used to transfer software versions between luminaires.

- Step 1. At last luminaire, install male termination connector into DATA THRU XLR connector.
- Step 2. At master luminaire (first in chain) Menu Display, press [ESC].
- Step 3. Press [Up] / [Down] arrows until **Fixture** appears.
- Step 4. Press [Up] / [Down] arrows until **Download** appears. Press [Enter].
- Step 5. **OK?** will be displayed. Press [Enter] to accept.
- Step 6. Download proceeds. (Download takes 4-5 seconds.) The number of blocks displayed is less in a luminaire-to-luminaire download than in a PC-to-luminaire download for the same software version.
- Step 7. When download is complete, luminaire automatically recalibrates. When recalibration is complete, luminaire is ready for operation with its new software version.

### Verify software version at luminaire:

- Step 1. At Menu Display, press [ESC].
- Step 2. Press [Up] / [Down] arrows until **Fixture** appears. Press [Enter].
- Step 3. Press [Up] / [Down] arrows until **Version** appears. Press [Enter].

The first half of the version will be displayed as a date (MM.DD.YY). For example, 03.18.03 (March 18, 2003).

Press [Up] / [Down] arrows to display second half of version. This will be displayed as a time (HH:MM). For example, 16:00





## ***CHAPTER 4.***

# Menu System

This chapter contains instructions for operating the luminaire using the Menu Display feature.

- **Menu Operation**
- **Menu Functions**

# Menu Operation

## What Is the Menu System?

The menu system is a programmable set of commands used to configure, address, operate, and test the luminaire. The menu system is controlled at the Menu Display available at the enclosure input panel.

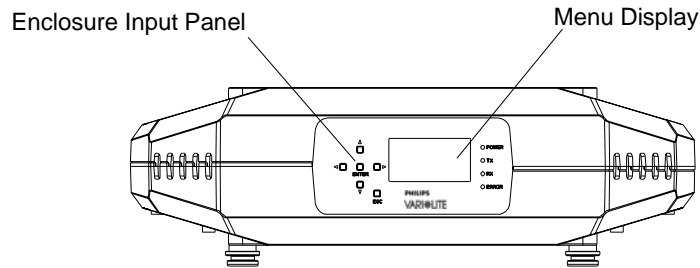

**Figure 4-1: Menu Display Location**



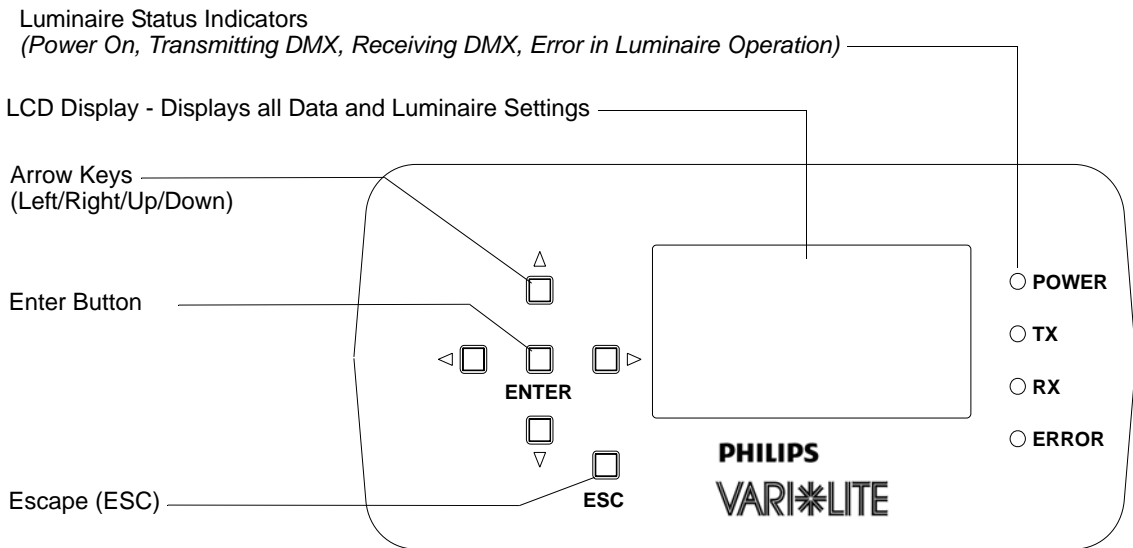

## Controls Operation

The menu system is controlled by an ENTER, ESC (Escape), and four Arrow (<△▽>) buttons. These buttons function as follows:



**Figure 4-2: VLX Menu Control**

Table 1-1: Menu Control Buttons

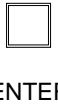
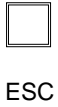
Button	Description	Action
	Up Arrow	Menu Navigation / Data Selection
	Down Arrow	Menu Navigation / Data Selection
	Right Arrow	Menu Navigation / Data Selection
	Left Arrow	Menu Navigation / Data Selection
	Enter Button	To Select or Change a Setting or Data Value
	Escape Button	Used to Access Main Menu Parameters, Exit, or Return to Previous Menu Item

**[ESC] button.** Displays the menu, or if at first level, the current address. Also used to return to previous menu item or to exit.

**[ENTER] button.** Selects the current menu option or stores current data value.

**[Up] / [Down] / [Left] / [Right] arrows.** Scrolls menu options upward or increases current data value.\*

\* LCD Display automatically sets to hanging orientation. See **Disp Tilt** in the [“Menu System Function Chart”](#) on page 46.

To enter the menu system, first press [ESC]. The functions displayed will be 1st level functions. Scroll through the 1st level functions by pressing [Up] / [Down] arrows. Once the desired function appears in the display, press [Enter]. You are now at the 2nd level. Once again, press the [Up] / [Down] arrows to scroll through 2nd level functions. Press [Enter] to access 3rd level functions and so forth. When the highest level for the function is reached, [Up] / [Down] arrows can be pressed to enter a value or select a toggle activation such as On/Off. Press [Enter] to store the value or select an action.

For example:

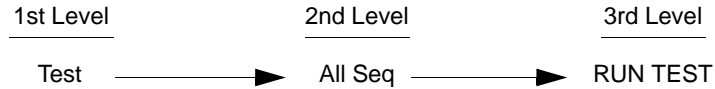

## Default State

The menu display's default state during normal operation is to display the DMX address. After 10 seconds of inactivity at the display, it will change to the default state.

After longer periods of inactivity, the menu display will switch to its off state. The default state for this feature is 5 minutes, however, different time lengths can also be programmed.

### **To program a different time length for menu off feature:**

- Step 1. Press [ESC].
- Step 2. Press [Up] / [Down] arrows until Config (Configuration) appears. Press [Enter].
- Step 3. Press [Up] / [Down] arrows to access Display. Press [Enter].
- Step 4. Press [Up] / [Down] arrows to select either 30 Sec (30 seconds), 5 Min (5 minutes), 10 Min (10 minutes), or ON (on indefinitely). Press [Enter] to set.

# Menu Functions

## Menu System Overview

The following is a graphic representation of the entire VLX™ Wash Luminaire menu system.

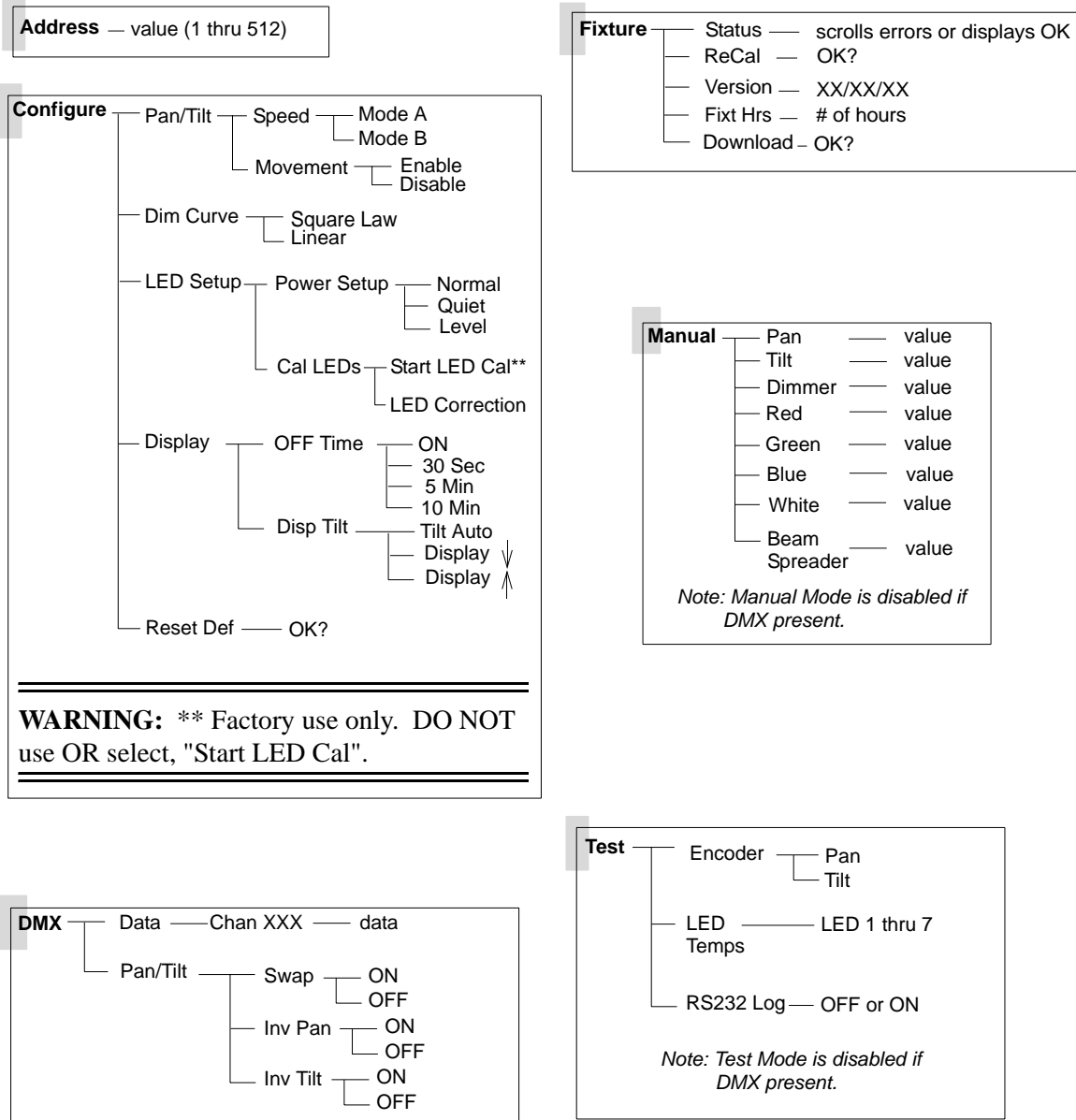

**Note:** For the latest version of this manual and luminaire software, please visit the Vari-Lite web site at [www.vari-lite.com](http://www.vari-lite.com) and click on the "Product Downloads" link on the VLX™ Wash Luminaire Products information page.

## Menu System Function Chart

The following is a detailed look at the internal menu system.

**Table 4-1: VLX Wash Menu System Chart**

1st Level	2nd Level	3rd Level	4th Level	5thLevel	
<b>Address</b>	<b>XXX</b> value 1 thru 512				
<b>Configure</b> Fixture configuration settings	<b>Pan/Tilt</b> Pan and Tilt	<b>Speed</b> Two operational speed settings of fixture movement	<b>Mode A</b> Increased responsiveness (Default)		
			<b>Mode B</b> Normal		
		<b>Movement</b> Position recovery	<b>Enable</b>		
			<b>Disable</b>		
	<b>Dim Curve</b> Fixture dimming operation	<b>Square Law</b> IES square wave sine dimming curve (Default)			
		<b>Linear</b> Standard linear dimming curve			
	<b>LED Setup</b> Settings for LED operation or calibration  <b>WARNING: DO NOT use OR select, "Start LED Cal". This is a factory use operation only.</b>	<b>Power Setup</b> Three levels of operation for fans and LEDs (Note, Quiet will reduce levels to minimize heat in fixture)		<b>Normal</b> Default	
				<b>Quiet</b> For reduced noise	
				<b>Level</b> Set to user's level (a set point between Normal and Quiet operation)	
		<b>Cal LEDs</b> To calibrate (Factory Use Only) or set LEDs to factory default calibration level	<b>Start LED Cal</b> (For Factory Use Only)		
			<b>LED Correction</b> Sets LEDs to factory calibration level		
	<b>Display</b> Display Illumination	<b>Off Time</b> Selects display off time		<b>ON</b> On indefinitely	
			<b>30 Sec</b> Off in 30 seconds		
			<b>5 Min</b> Off in 5 minutes		
			<b>10 Min</b> Off in 10 minutes		
<b>Disp Tilt</b> Display orientation - Factory default is Auto and other functions are currently disabled from selection.		<b>Auto</b> (Default)			
		<b>Up</b> - Currently Disabled			
	<b>Down</b> - Currently Disabled				
<b>Reset Default</b> Restores fixture to factory default	<b>OK?</b> Asks (confirms) to execute restoration of factory defaults of fixture				
<b>DMX</b> DMX Data	<b>DATA</b>	<b>Chan XXX</b> DMX Channel	<b>XXXX</b> Value 0 - 255		
	<b>Pan/Tilt</b> Pan and Tilt Options	<b>Swap</b> Swap Pan & Tilt	<b>ON</b>		
			<b>OFF</b>		
	<b>Inv Pan</b> Invert Pan	<b>ON</b>			
		<b>OFF</b>			
	<b>Inv Tilt</b> Invert Tilt	<b>ON</b>			
		<b>OFF</b>			

Table 4-1: VLX Wash Menu System Chart

1st Level	2nd Level	3rd Level	4th Level	5thLevel
<b>Fixture</b>	<b>Status</b> <i>Status/Error Display</i>	<i>Scrolls error messages or displays OK</i>		
	<b>Re Cal</b> <i>Recalibrate fixture</i>	<b>OK?</b> <i>Asks (confirms) to execute recalibration of fixture</i>		
	<b>Version</b> <i>Version</i>	<b>MM/DD/YY</b> (Page 1)	<b>HH:MM</b> (Page 2)	
	<b>Fixt Hrs</b> <i>Fixture Hours</i>	<b>XXXX #</b> <i>Number of Fixture Hours</i>		
	<b>Download</b> <i>Download Software</i>	<b>OK?</b> <i>Asks (confirms) to download software in fixture</i>		
<b>Manual</b> <i>Manual Commands (Disabled when DMX Present.)</i>	<b>Pan*</b>	<b>XXXXXX</b> <i>DMX Value</i>		
	<b>Tilt *</b>	<b>XXXXXX</b> <i>DMX Value</i>		
	<b>Dimmer*</b>	<b>XXXXXX</b> <i>DMX Value</i>		
	<b>Zoom*</b>	<b>XXXXXX</b> <i>DMX Value</i>		
	<b>Red*</b>	<b>XXXXXX</b> <i>DMX Value</i>		
	<b>Blue*</b>	<b>XXXXXX</b> <i>DMX Value</i>		
	<b>Green*</b>	<b>XXXXXX</b> <i>DMX Value</i>		
	<b>White*</b>	<b>XXXXXX</b> <i>DMX Value</i>		
<b>Test</b> <i>Fixture operational tests - Press [ESC] to stop tests</i>	<b>Encoder</b>	<b>Pan</b> <i>Pan encoder testing</i>	<b>RUN TEST</b>	
		<b>Tilt</b> <i>Tilt encoder testing</i>	<b>RUN TEST</b>	
	<b>LED Temps</b> <i>Temperature of LEDs (in degrees C)</i>	<b>LED 1 thru 7</b>	<b>RUN TEST</b>	
	<b>RS232 Log</b> <i>For factory use</i>	<b>OFF or ON</b>		

\* For 16-bit parameters, the data displayed will be scaled to a range of 0-65535.

## Menu Function Definitions

For easy reference, each possible menu item is listed alphabetically in the first column by its display abbreviation. The second column follows with a definition of the abbreviation and then a third column provides an explanation of its purpose and function.

**Table 4-2: Menu Function Definitions**

Display	Definition	Purpose
10 Min	10 Minutes	Sets Menu Display to automatically shut off after 10 minutes of non-use.
30 Sec	30 Seconds	Sets Menu Display to automatically shut off after 30 seconds of non-use.
5 Min	5 Minutes	Sets Menu Display to automatically shut off after 5 minutes of non-use.
Address	Address	Accesses option for setting luminaire DMX starting address.
All SEQ	All Sequence	Tests all internal mechanisms in sequence for X steps.
Auto	Automatic Operation	When set to "Auto", menu display will automatically orient itself in relation to fixture's hanging or sitting position (up or down).
Beam Spreader	Beam Spreader Mechanism	Specifies beam spread function for manual control ( <b>Manual</b> ) or testing ( <b>Test</b> ).
Blue	Blue LED	Specifies Blue color (intensity) for manual control ( <b>Manual</b> ) or testing ( <b>Test</b> ).
CAL LEDs	Calibrates LEDs	To start LED calibration or to set LEDs to specific factory calibration level
Channel XXX	DMX Channel	Specifies DMX channel for display of current data value.
Configure	System Configuration	Accesses options for pan/tilt operation, LED Setup, dimmer operational settings, and Menu Display defaults.
Data	DMX Data	Accesses option for setting DMX address channel.
Dim Curve	Dimmer Operation	Specifies dimmer to operate in Square Law or Linear Mode
Dimmer	Dimmer	Specifies dimmer mechanism for manual control ( <b>Manual</b> ) or testing ( <b>Test</b> ).
Disable	Disable	Disables a function.
Display	Display	Accesses options for Menu Display illumination time and orientation.
Display ↓	Display	Selects and sets menu display orientation of arrow direction.
Display ↑	Display	Selects and sets menu display orientation of arrow direction.
Disp Tilt	Menu orientation control	Sets the orientation of the menu display to match the luminaire orientation, ( <b>Auto</b> ) automatic display orientation, standing ( <b>Up</b> ) or hanging ( <b>Down</b> ).
DMX	DMX	Accesses options for DMX system settings.
Download	Download	Initiates download of luminaire software.
Enable	Enable	Enables a function.
Encoder	Encoder	Accesses pan/tilt encoders for diagnostic testing.
FAIL	Test Fail	Indicates that a test has failed.
Fixt Hrs	Fixture Hours	Displays total number of hours luminaire has been powered on.
Fixture	Fixture	Accesses luminaire information such as serial number, software version, and total operation hours. Also accesses recalibration and download options.
Green	Green LED	Specifies Green (intensity) parameter for manual control ( <b>Manual</b> ) or testing ( <b>Test</b> ).



Table 4-2: Menu Function Definitions (Continued)

Display	Definition	Purpose
Inv Pan	Invert Pan	Reverses pan action for special focus requirements.
Inv Tilt	Invert Tilt	Reverses tilt action for special focus requirements.
LED Cor- rection	LED Calibra- tion Level	Sets LEDs to factory calibration level.
LED Setup	LED Opera- tional Settings	LED settings/operation of power level or calibration.
LED Temps	LED Opera- tional Temper- ature	Measures temperature associated with LED operation - displays in degrees Celsius
Level	Fixture Mode	Luminaire setup is in set fixture mode by user.
Linear	Dimming Curve - Linear	Sets dimmer operation to standard linear dimming curve
Manual	Manual	Accesses options for luminaire mechanism control by entry of data values.
Movement	Movement	Enables or disables pan and tilt movement.
Normal	Fixture Mode	Luminaire setup is in normal fan and LED operational mode. (default)
OFF	Off	Turns off a function.
Off Time	Display off time	Shows the automatic shut-off time for the menu display.
OK	Okay	Indicates calibration has completed and no errors have occurred.
OK?	Okay?	Prompt for pressing [Enter] before an action is executed.
ON	On Indefinitely	Sets Menu Display to stay on until programmed otherwise ( <b>Display</b> ) or turns on a function.
Pan	Pan	Specifies pan function for manual control ( <b>Manual</b> ) or testing ( <b>Test</b> ).
Pan/Tilt	Pan/Tilt	Accesses pan and tilt options for focus swap function, movement enable/disable, manual control and testing.
PASS	Test Pass	Indicates that a test has passed.
PROG	Programming	In the process of programming the luminaire with the new version of software.
Quiet	Fixture Mode	Luminaire setup is in quiet mode (reduces fan and LED operation for quieter fixture operation).
Re Cal	Recalibrate	Recalibrates luminaire.
Red	Red LED	Specifies Red (intensity) for manual control ( <b>Manual</b> ) or testing ( <b>Test</b> ).
Reset Def	Reset Defaults	Resets default system configuration values.
RS232 Log	Factory Use Only	Sets logging function (ON or OFF) of RS232 data collection ( <i>for Factory Use Only</i> )
RUN TEST	Run Test	Indicates that a mechanism test is in progress.
SENS TST	Sensor Test	Indicates that a system sensor test is in progress.
Speed	Pan/Tilt Speed	Selects or sets pan and tilt operational speed.
Square Law	Dimmer Curve - Square Law	Sets dimmer operation to IES square wave dimming curve
Start LED CAL	Factory Use Only	<b>WARNING:</b> For factory use only - DO NOT use OR select, "Start LED Cal".
Status	Status/Error	Allows scrolling through error list or displays <b>OK</b> if no errors.
Swap	Swap	Swaps pan/tilt action for special focus requirements.

**Table 4-2: Menu Function Definitions (Continued)**

<b>Display</b>	<b>Definition</b>	<b>Purpose</b>
Test	Test	Accesses diagnostic tests for internal mechanisms or assemblies.
Tilt	Tilt	Specifies tilt function for manual control ( <b>Manual</b> ) or testing ( <b>Test</b> ).
Version	Version	Displays current software version date and time (in two pages).
White	White LED	Specifies White (intensity) parameter for manual control ( <b>Manual</b> ) or testing ( <b>Test</b> ).

## **APPENDIX A.**



# Troubleshooting and Maintenance

This appendix provides instructions for troubleshooting and routine maintenance which may be necessary during the life of the luminaire.

- **Troubleshooting**
- **Routine Maintenance**



**WARNING:** All routine maintenance procedures are to be performed with power completely removed from the luminaire. Never remove protective covers when luminaire is powered. Wear appropriate protective eye wear and gloves when servicing the fixture. All service and maintenance, other than described herein should be performed by an Authorized VARI\*LITE® Dealer or Service Center.

---

---



**WARNING:** DO NOT connect or disconnect energized power cable at fixture (under load). Turn off circuit breaker (or completely de-energize circuit) before connecting or disconnecting power cable at fixture. Power is only removed from the fixture by disconnecting power cable from source or turning off source circuit breaker.

---

---

# Troubleshooting

## Error Messages

If a problem occurs during luminaire calibration, at the end of the calibration sequence the Menu Display cycles through any applicable error message(s) until the end of the list is reached. To review the error messages again, re-access them using the **Status** function.

**To access error messages:**

- Step 1. Press [ESC] to access the main menu screen.
- Step 2. Press [Up] / [Down] arrows until **Fixture** appears. Press [Enter].
- Step 3. Press [Up] / [Down] arrows to access **Status**. Press [Enter]. (Display will now scroll through any error messages or display **OK** if no errors.)

**Table A-1: Error Messages**

Display	Message
OK	No Errors Found
Tilt Sensor	Tilt Sensor not found

- Step 4. If an error occurs, recalibrate fixture. If error message persists, then contact an Authorized VARI\*LITE® Dealer or Service Center for support.

## Troubleshooting Guide

If a problem is suspected, first try recalibrating the luminaire to prompt an error message. The chart below provides possible causes and remedies for various error messages and/or symptoms.



**WARNING:** All service and maintenance (including troubleshooting), other than described herein should be performed by an Authorized VARI\*LITE® Dealer or Service Center.

**Table A-2: Troubleshooting Chart**

Message	Description	Symptom	Possible Cause/Remedy
n/a	No light output	Fixture will not produce or output light	Component Failure... - check fans for proper connection and operation.
n/a	No power	Luminaire does not power up	Circuit not energized... - verify circuit breaker is turned on. Not plugged in... - ensure A/C cable is connected to power source. Power cable wired incorrectly... - verify power cable and connector are wired correctly. (See “Power and Data Cabling Requirements” on page 10.)
n/a	DMX Data Input	Self tests will not run or software download does not work.	Detecting DMX data... - disconnect DMX input cable.
n/a	DMX Failure	No response to DMX data	MCB connector disconnected... - check MCB DATA IN connection. DMX data cable not wired correctly or has a broken conductor... - check DMX data cable for proper wiring. (See “Power and Data Cabling Requirements” on page 10.)
n/a	DMX Termination	Erratic control of luminaire	No DMX termination or termination not correct... - check for DMX terminator. (See “Male Termination Connector” on page 13.)

# Routine Maintenance

---

## Introduction

Being a solid-state fixture, and unlike most automated arc or tungsten fixtures, the VLX™ Wash Luminaire requires very little routine maintenance by the user. This section covers all the parts or assemblies that can be removed, cleaned, and checked by the user. Any additional maintenance or service should only be completed by an Authorized VARI\*LITE® Service Center.

---

## Special Cleaning and Care Instructions

The VLX™ Wash Luminaire requires special care when it comes to cleaning front lens assembly.

---



**Note:** Additional care needs to be taken with the plastic components because they are much easier to scratch or damage than glass.

---

The following is a list of cleaning materials required to care for your VLX™ Wash Luminaire:

- Lint free lens tissue
- Lint free cotton swabs (for hard-to-reach spot cleaning)
- Lint or powder free gloves
- Reagent grade isopropyl alcohol
- A mild soap solution.

Reagent grade isopropyl alcohol is good to use on the VLX™ Wash Luminaire plastic optics with anti-reflection coatings.

If the lens is still dirty after using isopropyl alcohol, for instance if fingerprints or oil is just redistributed and not cleaned off the optic, then a mild soap and water solution can be used to gently wash the lens. Repeat the cleaning with isopropyl alcohol to eliminate streaks and soap residue.

---

---



**WARNING:** Under no circumstances should ammonia-based cleaners, acetone, or other harsh solvents be used on or near the VLX™ Wash Luminaire. These types of cleaners or solvents can permanently damage the optics or housings of the fixture.

---

---

If you have any questions regarding the use or care of your VLX™ Wash Luminaire, please contact Vari-Lite technical support at 1.877-VARI-LITE or +1.214.647.7880.

## Front Lens Removal and Cleaning

Tools:

- #2 Phillips screwdriver
- Slotted Screwdriver
- Refer to the list of cleaning materials in “[Special Cleaning and Care Instructions](#)” on page 54



**WARNING:** Ensure that power is completely removed from luminaire before attempting any work. Always wear eye protection and proper gloves when performing this procedure.

### To clean from lens assembly and optics:

- Step 1. Remove power from luminaire and allow unit to completely cool.
- Step 2. Carefully set luminaire on upper enclosure, rotate head as shown in [Figure A-1](#), and engage tilt lock.

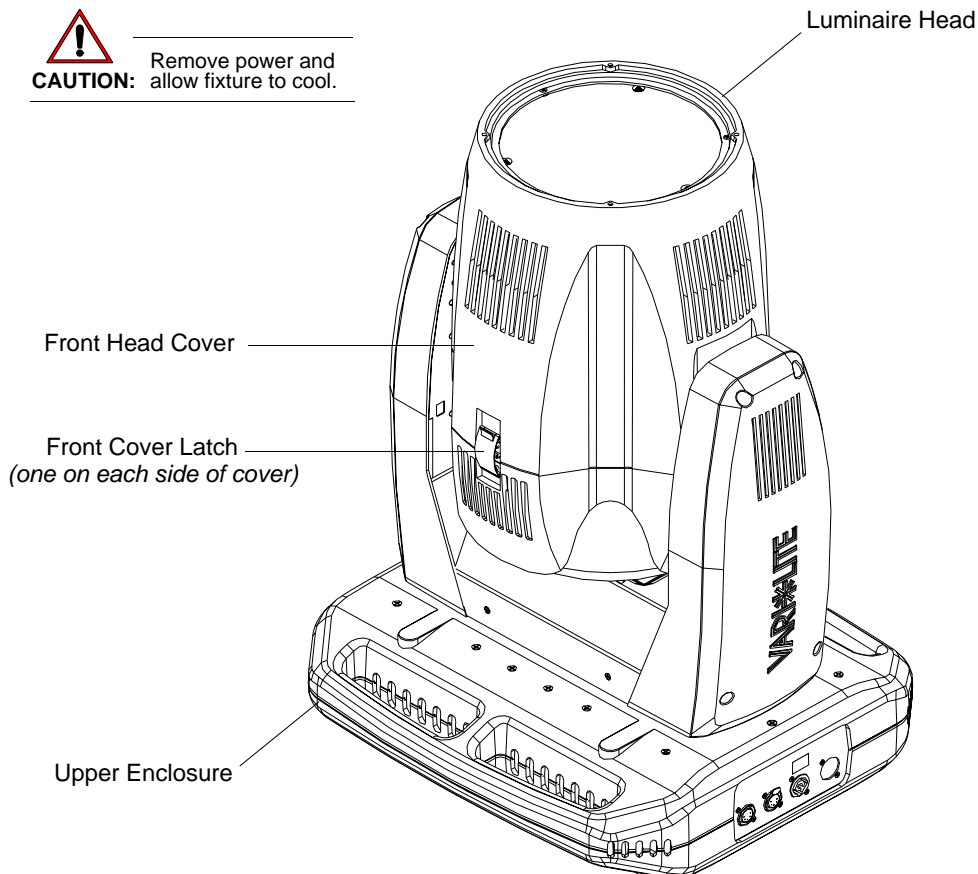

**Figure A-1: VLX™ Wash Luminaire**

- Step 3. Remove front head cover by unlatching both head cover latches. Please note that one side of front cover is secured by a safety tether. Locate clip attached to luminaire and unclip tether.

Step 4. Gently slide front head cover over optic assembly and set aside.

Step 5. Remove protective EMI shields from around optics assembly as shown in [Figure A-2](#) as follows:



**WARNING:** On one EMI shield, it is imperative to identify the ambient temperature sensor that protrudes through the EMI protective shield (it is on the opposite side where the front cover safety tether connects). When this shield is removed, great care has to employed not to damage the sensor.

- a. At EMI shield (side where front cover safety tether connects), remove all screws securing cover. Be sure to note locations of removed screws in relation to EMI shield.
- b. Remove shield and set aside.
- c. At other EMI shield (side with ambient temperature sensor), remove all screws securing cover. Be sure to note locations of removed screws in relation to EMI shield.
- d. Carefully work shield over ambient temperature sensor taking care not to snag or pull sensor. Once shield is clear of sensor, set shield aside.

**Note:**  
Some components not shown for clarity.

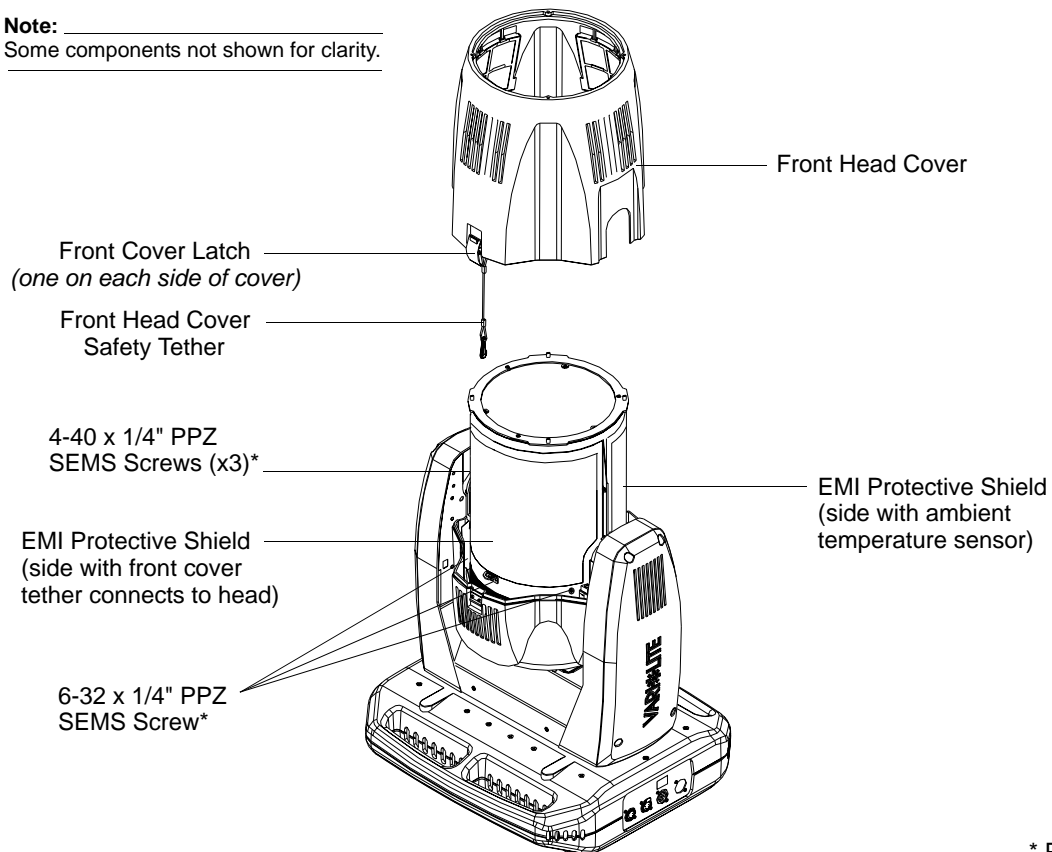

**Figure A-2: Front Head Cover and EMI Shields Removal**

Step 6. At head assembly, as shown in [Figure A-3](#), remove front lens assembly as follows:



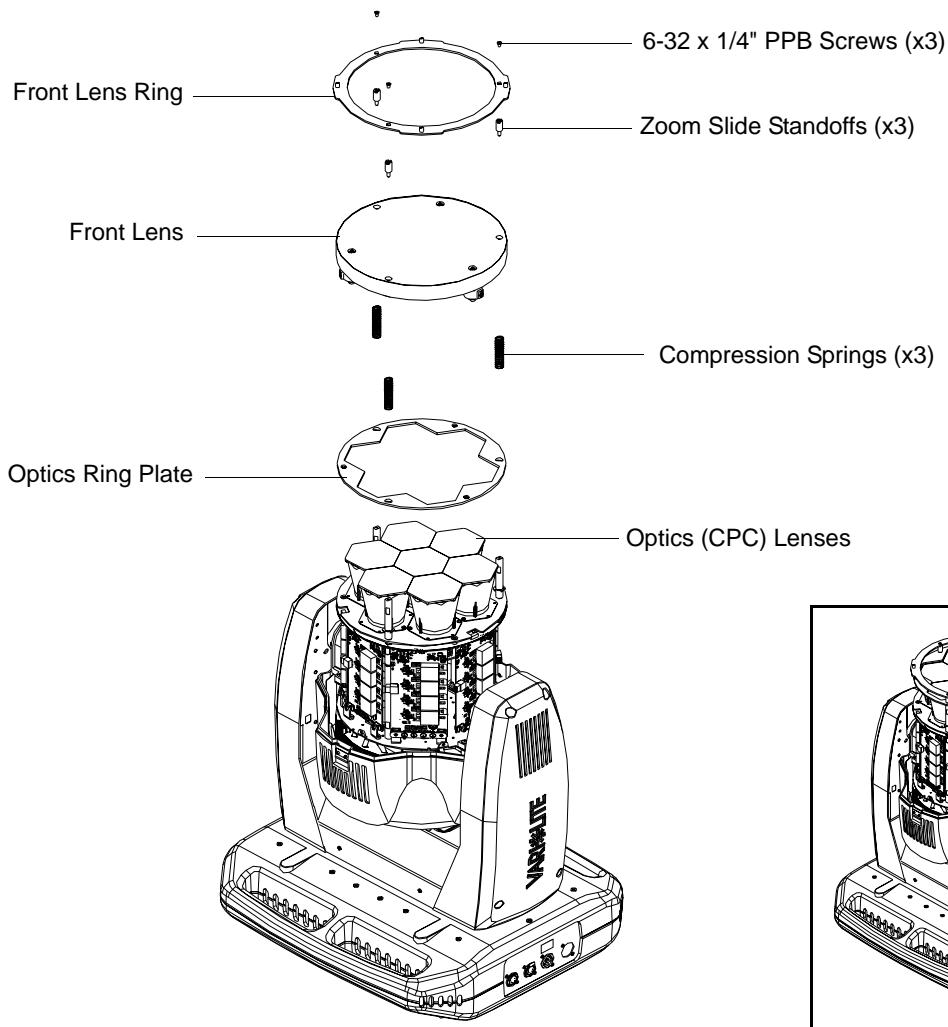

**Figure A-3: Front Lens Removal**



**Note:** Before proceeding, please note orientation of both front lens ring and front lens assembly. They must be mounted in their original orientation/position for the front head cover to reinstall properly.

- a. Remove three screws securing front lens and lens ring. Set components aside.
  - b. Note zoom motor wiring and routing. Disconnect wiring from zoom motors.
  - c. At front lens, loosen and remove and remove three stand-offs. Remove lens and place lens on a clean, lint free cloth as not to damage or scratch lens.
  - d. Remove three compression springs and optic ring plate. Set components aside.
- Step 7. Clean front lens and optics according to the guidelines set forth in [“Special Cleaning and Care Instructions”](#) on page 54.

Step 8. Once cleaning is complete, reassemble by performing Steps 6 through 2 in reverse order. Be sure to orient front lens as shown in [Figure A-4](#).



**WARNING:** Front Lens Assembly must be mounted in orientation show. If installed incorrectly, luminaire performance will be affected.

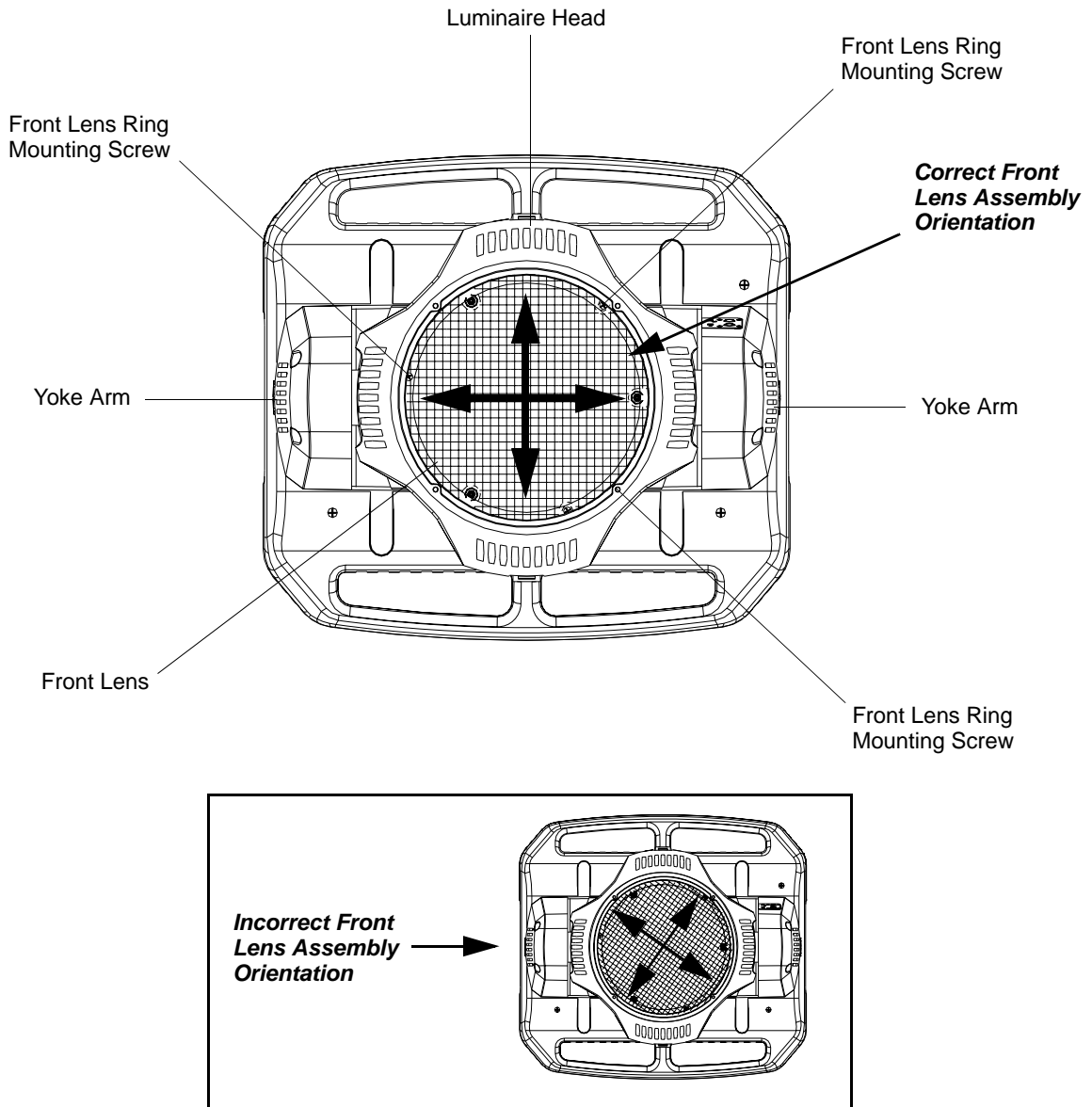

**Figure A-4: Front Lens Orientation**

Step 9. When reinstalling front head cover, be sure not to let cover edge come in contact with optics (CPC) lenses.

Step 10. Once luminaire is reassembled, power and test.

## Beam Spreader Removal for Fixed Beam Applications

Tools:

- #2 Phillips screwdriver
- Slotted screwdriver



**WARNING:** Ensure that power is completely removed from luminaire before attempting any work. Always wear eye protection and proper gloves when performing this procedure.

### To remove beam spreader assembly for fixed beam applications:

- Step 1. Remove power from luminaire and allow unit to completely cool.
- Step 2. Carefully set luminaire on upper enclosure, rotate head as shown in [Figure A-1](#), and engage tilt lock.

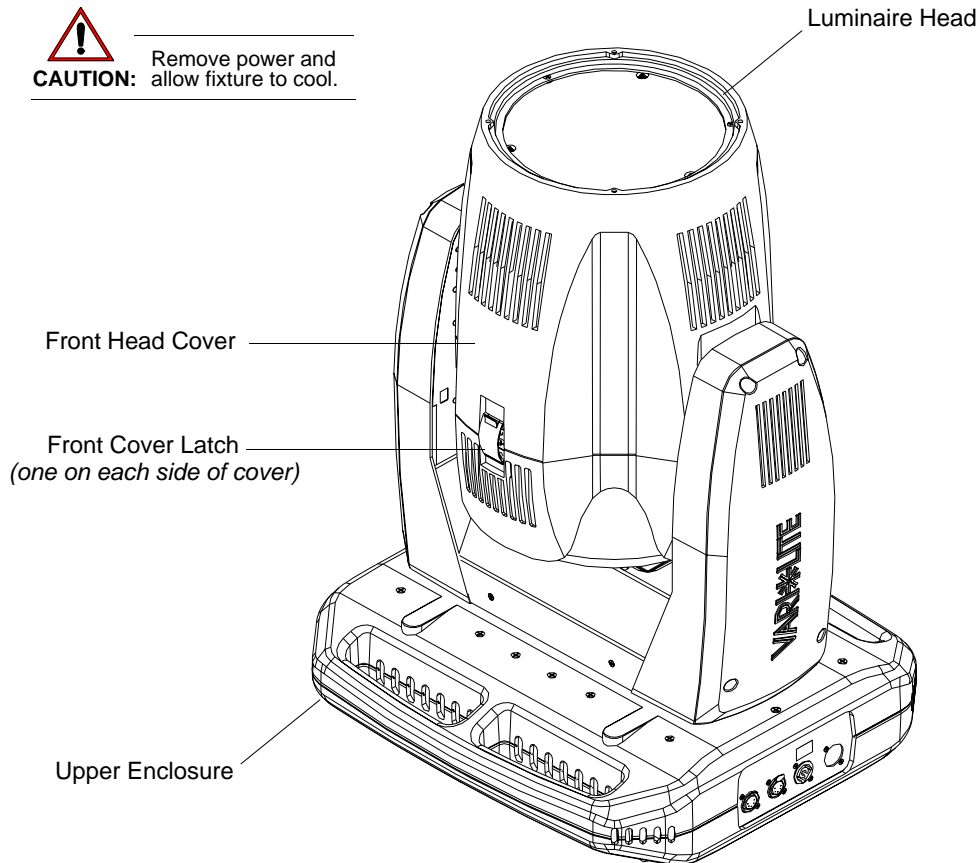

**Figure A-5: VLX™ Wash Luminaire**

- Step 3. Remove front head cover by unlatching both head cover latches. Please note that one side of front cover is secured by a safety tether. Locate clip attached to luminaire and unclip tether.
- Step 4. Gently slide front head cover over optic assembly and set aside.

Step 5. Remove protective EMI shields from around optics assembly as shown in [Figure A-2](#) as follows:



**WARNING:** On one EMI shield, it is imperative to identify the ambient temperature sensor that protrudes through the EMI protective shield (it is on the opposite side where the front cover safety tether connects). When this shield is removed, great care has to be employed not to damage the sensor.

- a. At EMI shield (side where front cover safety tether connects), remove all screws securing cover. Be sure to note locations of removed screws in relation to EMI shield.
- b. Remove shield and set aside.
- c. At other EMI shield (side with ambient temperature sensor), remove all screws securing cover. Be sure to note locations of removed screws in relation to EMI shield.
- d. Carefully work shield over ambient temperature sensor taking care not to snag or pull sensor. Once shield is clear of sensor, set shield aside.

**Note:**  
Some components not shown for clarity.

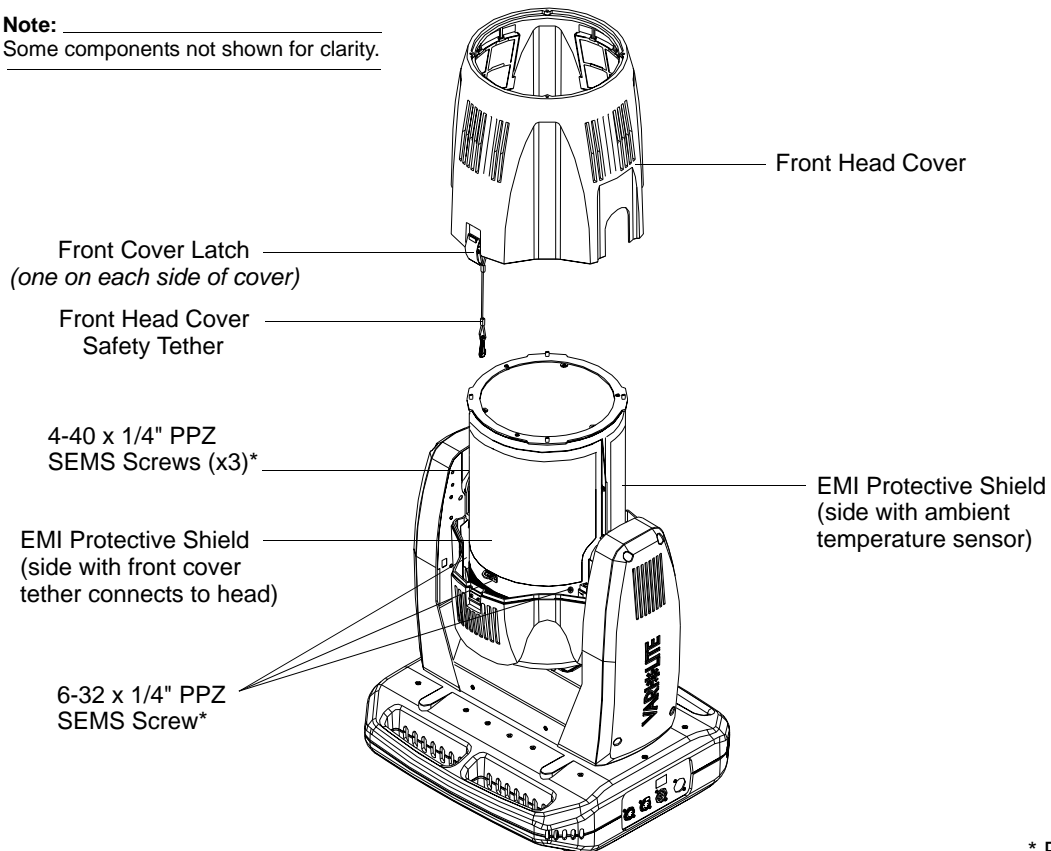

\* Per shield.

**Figure A-6: Front Head Cover and EMI Shields Removal**

Step 6. At head assembly, as shown in [Figure A-3](#), remove front lens assembly as follows:

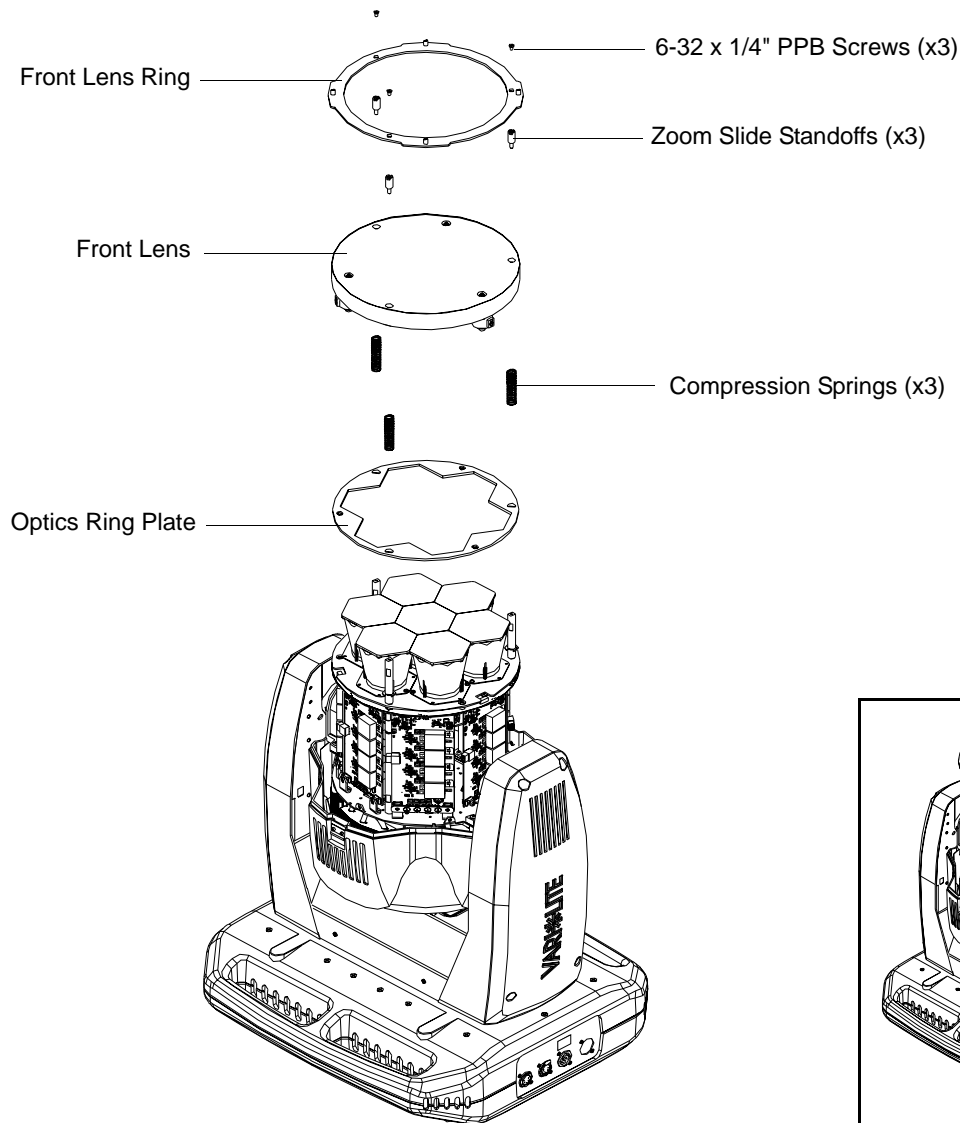

**Figure A-7: Front Lens Removal**

- a. Remove three screws securing front lens and lens ring. Set components aside.
- b. Note zoom motor wiring and routing. Disconnect wiring from zoom motors.
- c. At front lens, loosen and remove and remove three stand-offs. Remove lens and place lens on a clean, lint free cloth as not to damage or scratch lens.
- d. Remove three compression springs and optic ring plate. Set components aside.

Step 7. Reassemble luminaire for fixed beam applications as follows:

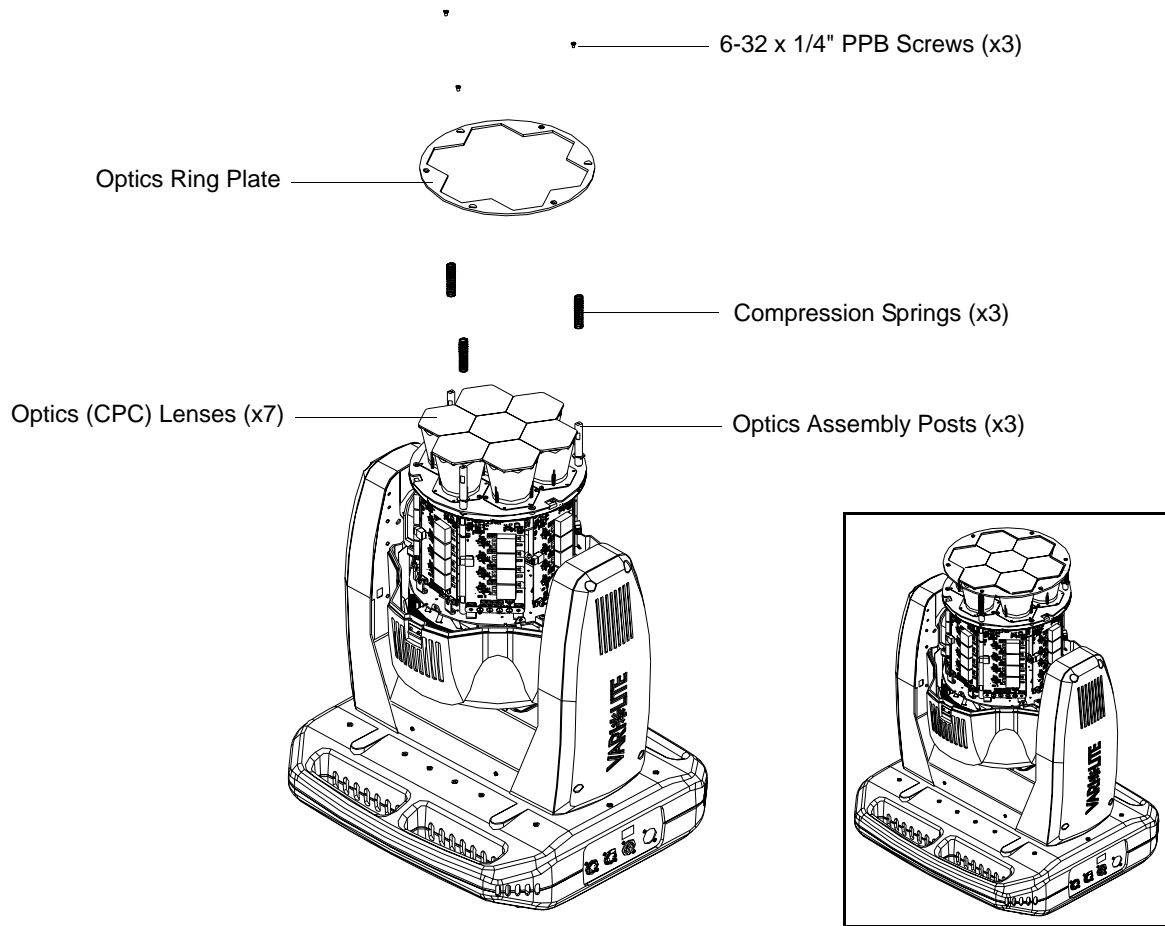

**Figure A-8: Fixed Beam Application Assembly**

- a. As shown in [Figure A-8](#), slide compression springs over optics assembly posts.
  - b. Turn optics ring (60°) so its mounting holes are in line with optics assembly posts but does not slide over optics (CPC) lenses.
  - c. Using three 6-32 x 1/4" PPB screws, secure Optics Ring Plate to assembly.
- Step 8. Reinstall EMI protective shields. Use care when installing EMI shield on side of ambient temperature sensor as not to damage sensor.
- Step 9. Reinstall front head cover. Be sure not to let cover edge come in contact with optics (CPC) lenses.
- Step 10. Once luminaire is reassembled, power and test.



**Note:** Carefully store front lens in a soft lint-free, non-abrasive covering for future use. Be sure to keep all parts (removed with front lens) with front lens in a separate container (as not to damage lens).

## APPENDIX B.



# Technical Specifications

---

## VLX™ Wash Luminaire

### PROGRAMMABLE FUNCTIONS

#### Color Mixing System

Seven x 90 watt RGBW CBM380 LED chipsets\*.

*\* Each chipset contains high density red, green, blue, and white LED emitters.*

#### Zoom Optics

Patented optical zoom system with continuously variable field angle from approximately 23° to 60°. Zoom module is easily removable for fixed field angle of 22°.

#### Intensity Control

Smooth, high resolution dimming control of Red (R), Green (G), Blue (B), and White (W) LED's.

#### Strobe

High speed with multiple strobe effects.

#### Pan and Tilt

Smooth, time-controlled continuous motion by way of a pair of three-phase stepper motor systems. Pan range is 540°/ Tilt range is 270° both with a 0.3° resolution.

### OPTICAL

#### Source

Seven x 90 watt CBM380 RGBW chipsets.

Color Temp. White: Variable between 3000 and +9000 Kelvin.

CRI: 93

Manufacturer Rated Life: In excess of 50,000 hours. (L10 – 70%)

#### Output

Exceeds 10,000 lumens

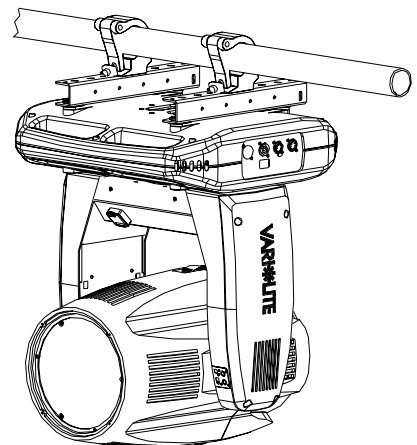

## PHOTOMETRIC

Zoom	LED Mode	Field Angle	Lumens	CCT
Narrow	RGBW	22.9°	12244	9272
Wide	RGBW	57.8°	10857	8523
Without Lens Array	RGBW	21.9°	13922	8866

## OPERATIONAL

### Power Requirements

Standard AC power distribution from 100-240 VAC, 50/60 Hz. The fixture requires up to 9 A depending on the AC supply voltage.

### Operational Temperature

-20° to 122°F (-29° to 50°C)

### Cooling

Variable forced air cooling.

### Control

Completely compatible with a wide variety of DMX512 lighting control consoles. 23 channels. 5-pin in and thru DMX.

### Weight

62 lbs. (28.2 kg) with included pair of hanging rails.

### Spacing

Hangs on 22.0 inch (559 mm) centers. All models can be mounted and operated in any orientation.







Vari-Lite  
10911 Petal Street  
Dallas, Texas 75238 USA  
1-877-VARI-LITE \* 1-214-647-7880  
[www.vari-lite.com](http://www.vari-lite.com)

©2009 Vari-Lite, a Philips group company. All Rights Reserved.