

K 1/SB28

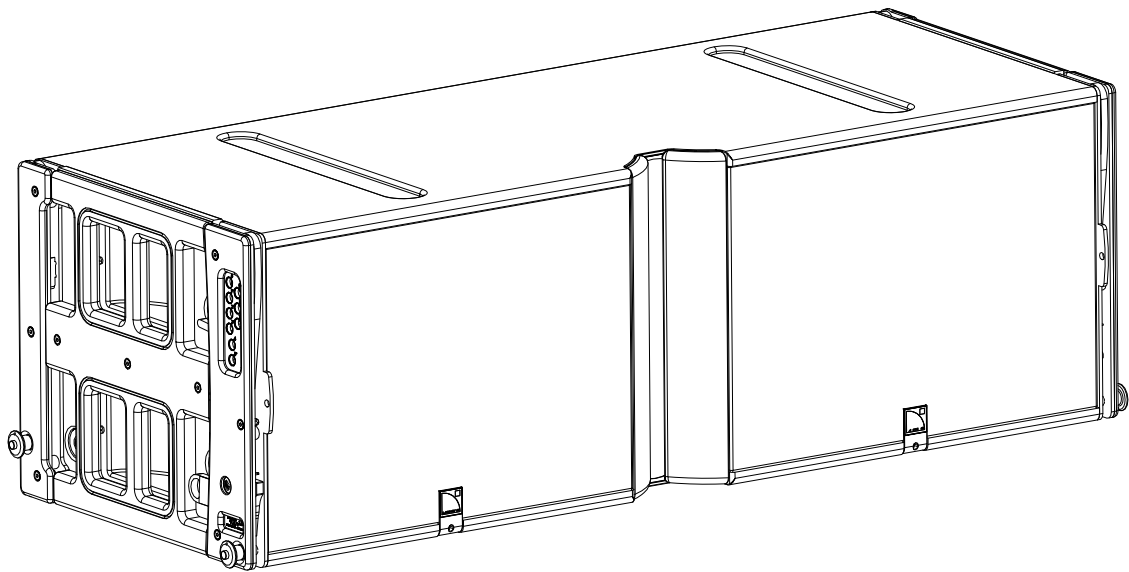

user manual (EN)



Document reference: K1/SB28 user manual (EN) version 5.0

Distribution date: March 7, 2017

© 2017 L-Acoustics. All rights reserved.









No part of this publication may be reproduced or transmitted in any form or by any means without the express written consent of the publisher.

Contents

Safety.....	4
Instructions.....	4
Symbols.....	4
Welcome.....	5
System components.....	6
Loudspeaker cables.....	7
Technical description.....	8
K1-SB applications.....	8
Loudspeaker configurations.....	9
Line source.....	9
Additional subwoofer system.....	11
K1-SB.....	11
SB28.....	14
Additional downfill element.....	16
Kara.....	16
K2.....	17
Loudspeaker connection.....	18
Connectors.....	18
Connection to LA8.....	20
Preset description.....	23
Recommendation for speaker cables.....	24
Specifications.....	25
K1 specifications.....	25
K2 specifications.....	27
Kara specifications.....	29
K1-SB specifications.....	30
SB28 specifications.....	32



Safety

Instructions

-  **Inspect the product before operation.**
If any sign of defect or damage is detected, immediately withdraw the product from use for maintenance.
-  **Never incorporate equipment or accessories not approved by L-Acoustics.**
-  **Read all the related PRODUCT INFORMATION documents shipped with the products before exploiting the system.**
-  **Do not store the product on an unstable cart, stand, tripod, bracket, or table.**
-  **Beware of sound levels.**
Do not stay within close proximity of loudspeakers in operation.
Loudspeaker systems are capable of producing very high sound pressure levels (SPL) which can instantaneously lead to permanent hearing damage to performers, production crew and audience members. Hearing damage can also occur at moderate level with prolonged exposure to sound.
Check the applicable laws and regulations relating to maximum sound levels and exposure times.
-  **This system is intended for professional use.**
-  **Read the RIGGING MANUAL before installing the system.**
Use the rigging accessories described in the rigging manual and follow the associated procedures.
Read the maintenance section of this document before servicing the product.
-  **Do not expose the product to extreme conditions.**
Do not expose the product to rain or sea spray.
Do not expose the product to moisture (mist, steam, humidity, condensation...) or excessive heat (direct sun, radiator...) for a long period of time.
-  **Contact L-Acoustics for advanced maintenance.**
Any unauthorized maintenance operation will void the product warranty.

Symbols

The following symbols are used in this document:

-  This symbol indicates a potential risk of harm to an individual or damage to the product.
It can also notify the user about instructions that must be strictly followed to ensure safe installation or operation of the product.
-  This symbol notifies the user about instructions that must be strictly followed to ensure proper installation or operation of the product.
-  This symbol notifies the user about complementary information or optional instructions.

Welcome

Thank you for purchasing the L-Acoustics K1.

This document contains essential information on using the system properly.

As part of a continuous evolution of techniques and standards, L-Acoustics reserves the right to change the specifications of its products and the content of its document without prior notice. Please check www.l-acoustics.com on a regular basis to download the latest document and software updates.

K1 large format WST line source

The K1 enclosure is the full-range element of a large format WST[®] line source with variable curvature. The K1 features two 15" speakers mounted in a bass-reflex enclosure, four 6.5" high-efficiency direct radiating speakers, and three 3" diaphragm compression drivers coupled to individual DOSC[®] waveguides. The transducers are implemented in a K-shape configuration. The K1 enclosure is based on a 3-way active design with 2 LF sections, 1 MF section and 1 HF section, each one at the nominal impedance of 8 ohms. The K1 enclosure is made of first grade Baltic birch plywood to ensure maximum acoustical and mechanical integrity. A four-point rigging system is integrated into the cabinet.

The K1 enclosure operates over the nominal frequency range of 35 Hz to 20 kHz. The frequency response of the system can be extended down to either 30 Hz or 25 Hz with the addition of the dedicated K1-SB extension, or the SB28 subwoofer, respectively. The K1 generates a symmetric horizontal coverage of 90°.

The rigging system allows vertically assembling K1 enclosures with various inter-element angles up to 5°, constituting a line array with variable curvature. The combination of the coplanar symmetry and the DOSC[®] waveguide in the HF region ensure a perfect acoustic coupling between the elements of an array. The WST[®] (Wavefront Sculpture Technology) criteria are fulfilled, so that such an array can be qualified as a true line source. Any WST[®] line source provides a smooth tonal response and a coverage that is free of secondary lobes over the entire frequency range.

The K1 system is driven by the LA8 amplified controller which ensures active system linearization, intelligent transducer protection, and optimization of the loudspeaker system in its different operating modes. The acoustic performances of the system will depend upon the used preset and the chosen physical configuration

System components

Loudspeaker enclosures

K1	3-way full-range active WST® enclosure
K2	3-way full-range active WST enclosure
Kara	2-way modular WST® enclosure
K1-SB	K1 system subwoofer 2x15"
SB28	High power subwoofer: 2 x 18"

Powering and driving system

LA8	Amplified controller with DSP, preset library and networking capabilities
LA-RAK	Touring Rack (RK9U/3xLA8/LA-POWER/ LA-PANEL/LA-PANELAES3/2U panels)



Refer to the LA8 user manual for operating instructions.

Loudspeaker cables

SP cables	4-point speakON loudspeaker cables (4 mm ² gauge) SP cables come in four sizes: SP.7 (0.7 m/2.3 ft), SP5 (5 m/16.4 ft), SP10 (10 m/32.8 ft) and SP25 (25 m/82 ft)
SP-Y1	breakout cable for two passive enclosures (2.5 mm ² gauge) provided with a CC4FP adapter 4-point speakON to 2 x 2-point speakON
DO	8-point PA-COM loudspeaker cables (4 mm ² gauge) DO cables come in three sizes: DO.7 (0.7 m/2.3 ft), DO10 (10 m/32.8 ft) and DO25 (25 m/82 ft)
DOSUB-LA8	breakout cable for four passive enclosures (4 mm ² gauge) 8-point PA-COM to 4 x 2-point speakON
DOFILL-LA8	breakout cable for two 2-way active enclosures (4 mm ² gauge) 8-point PA-COM to 2 x 4-point speakON
DO3WFILL	breakout cable for one 2-way active enclosure and two passive enclosures (4 mm ² gauge) 8-point PA-COM to 1 x 4-point speakON and 2 x 2-point speakON



Information about the connection of the enclosures to the LA amplifiers is given in this document.

Refer to the LA8 user manual for detailed instructions about the whole cabling scheme, including modulation cables and network.

Rigging elements



Rigging elements or procedures are not presented in this document.
Refer to the K1 rigging manual.

Software applications

Soundvision 3D acoustical and mechanical modeling software

LA Network Manager Software for remote control and monitoring of amplified controllers

i Refer to the **Soundvision** help.

i Refer to the **LA Network Manager video tutorial**.

Loudspeaker cables

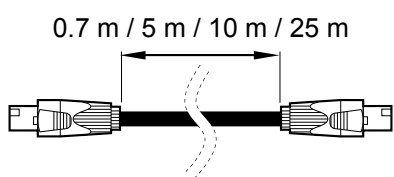

SP.7 / SP5 / SP10 / SP25

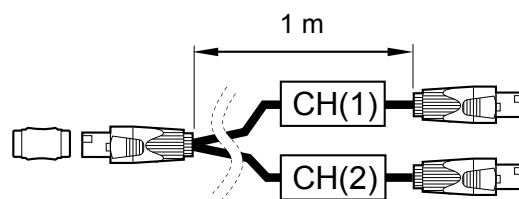

SP-Y1

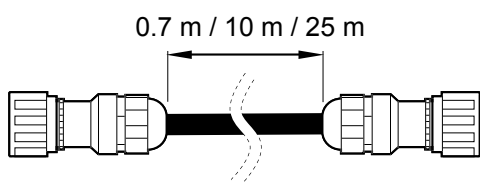

DO.7 / DO10 / DO25

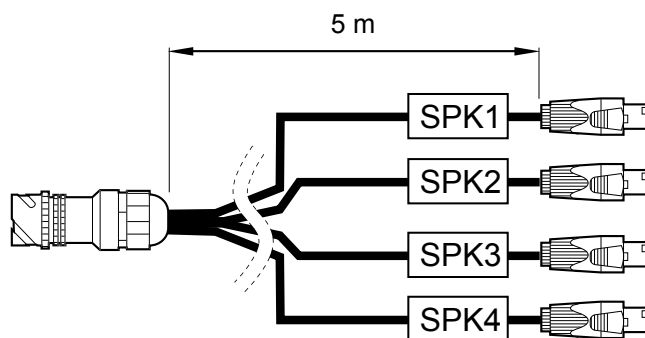

DOSUB-LA8

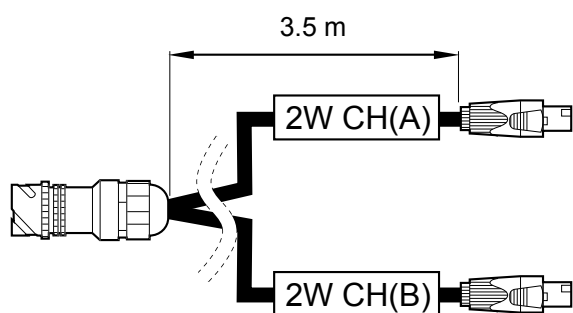

DOFILL-LA8

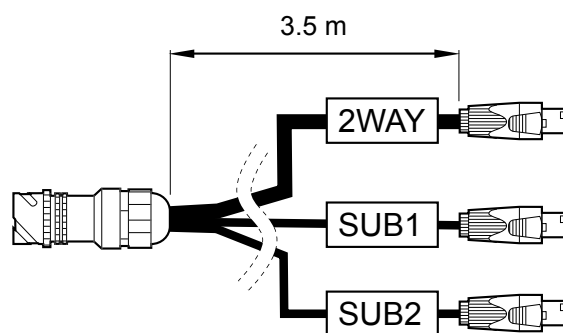

DO3WFILL

Technical description

K1-SB applications

There are two distinct applications for K1-SB in a K1 system:

- As an LF extension in a line source for enhanced throw, using the [K1SB_X] preset with K1
- As a subwoofer for increased impact, using the [K1SB_60] preset



Both applications of K1-SB can be combined in the same configuration.

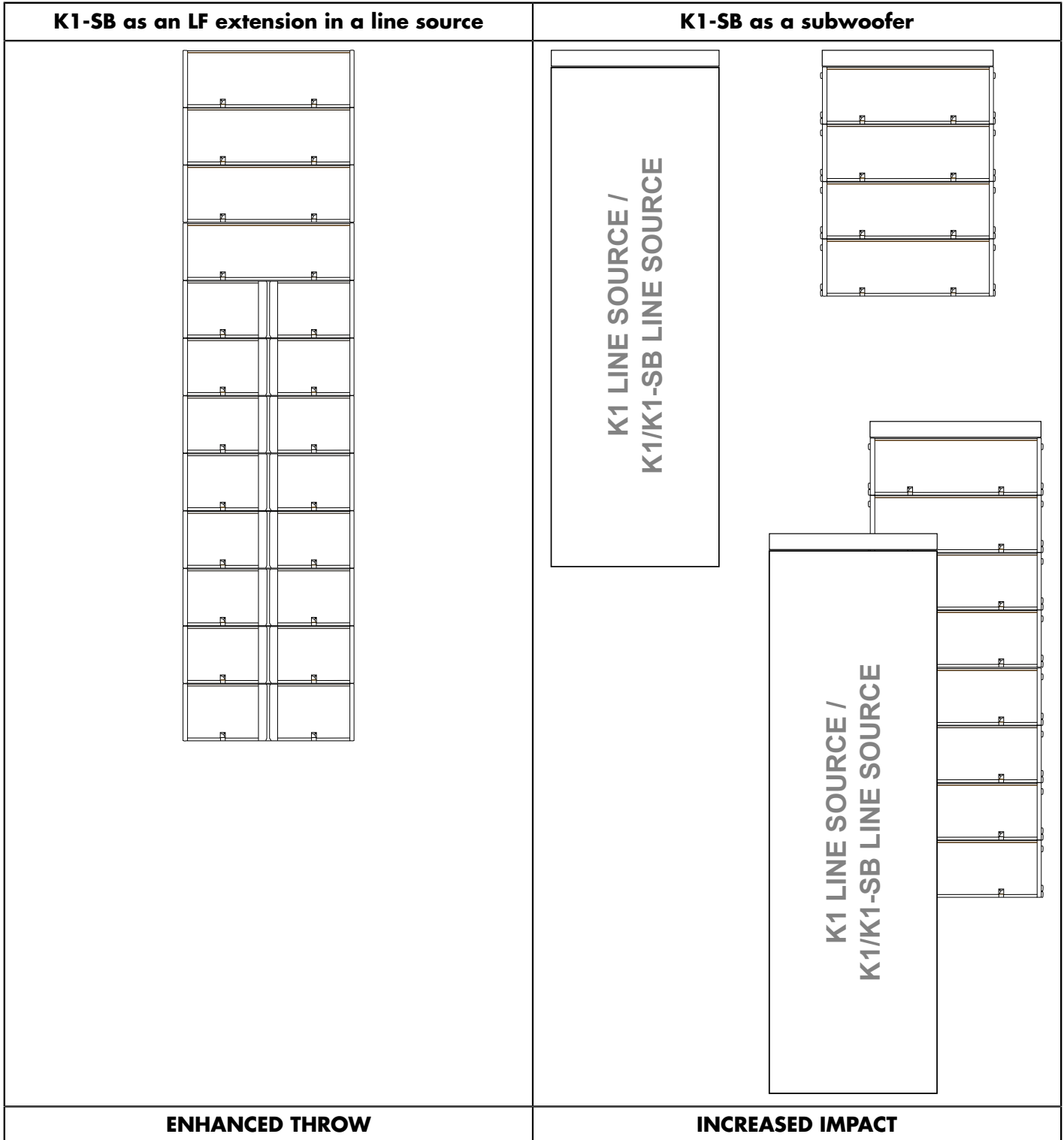

Loudspeaker configurations

Line source

Deployed as a line source, the system operates over the nominal bandwidth of the K1 enclosure.

Two configurations are possible:

- K1 line source
- K1/K1-SB line source: enhanced LF throw

By providing the K1-SB with the same frequency response as the K1 low section, the [K1SB_X] preset allows the K1-SB enclosure to be used as an LF line source element, increasing the length of the sub-low line source.

The K1 and K1-SB enclosures are driven by the LA8 amplified controllers.

Standalone K1 line source

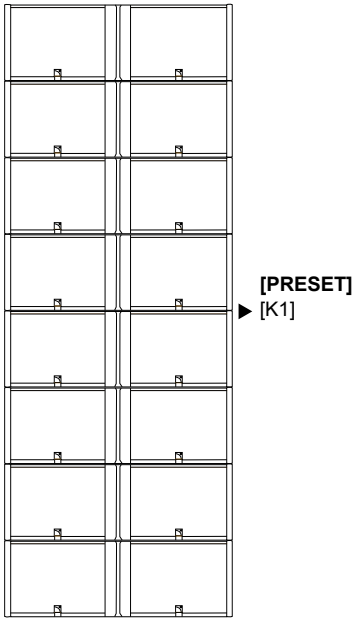
	
Enclosure	K1
Preset	[K1]
Frequency range (-10 dB)	35 Hz - 20 kHz

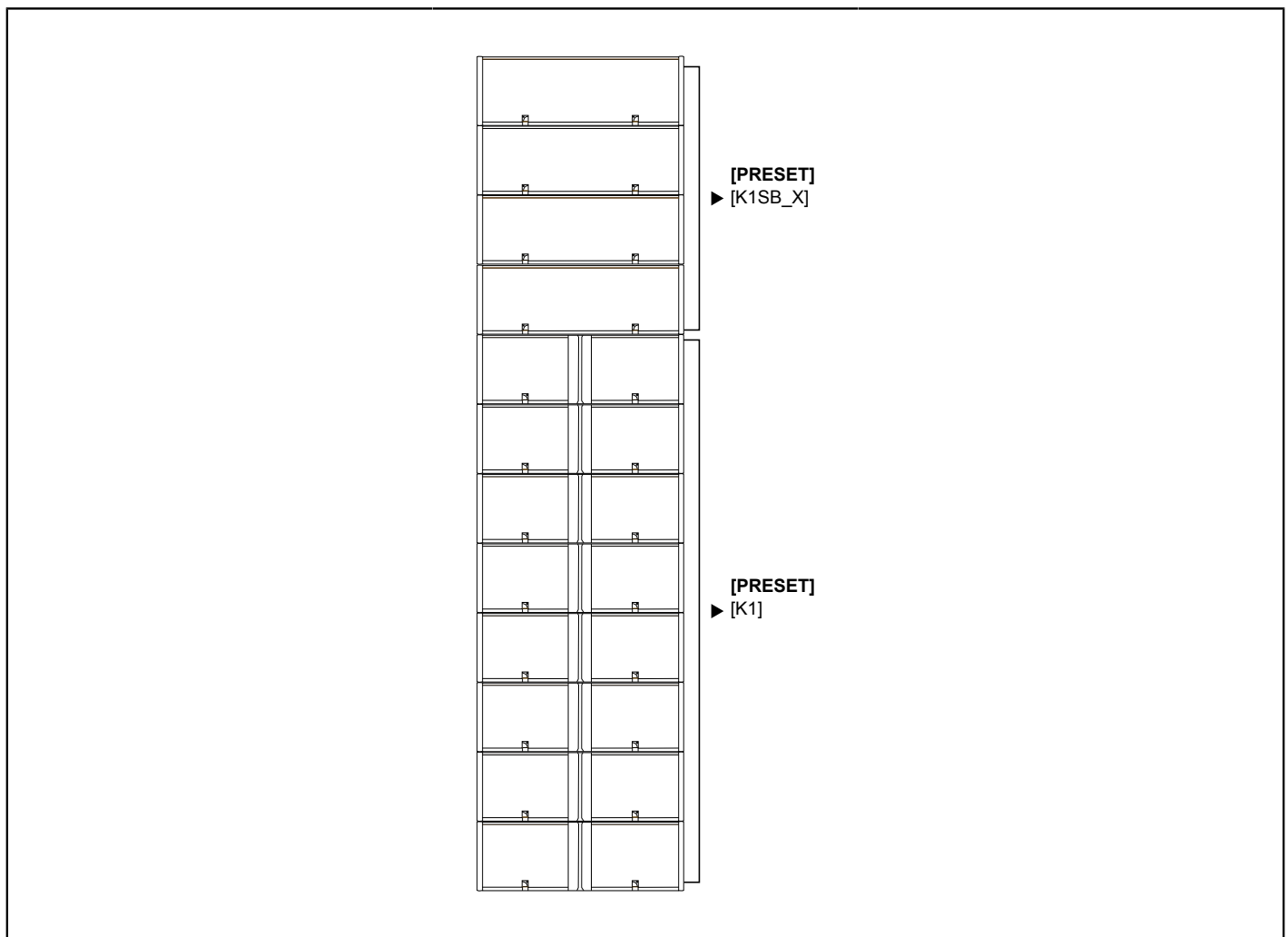
K1/K1-SB line source

Enclosure	K1	K1-SB
Preset	[K1]	[K1SB_X]
Frequency range (-10 dB)	35 Hz - 20 kHz	
Recommended ratio	2 K1 : 1 K1-SB	
Minimum line length	8 K1 + 4 K1-SB	



When using [K1] with [K1SB_X], do not add any delay value between the K1 and K1-SB elements of a same line source.

Additional subwoofer system

A K1 line source or a K1/K1-SB line source can be deployed with additional subwoofer enclosures to provide increased sub-low resources to demanding applications.

Two subwoofer systems are available:

- K1-SB for increased impact
- SB28 for infra extension

The recommended ratio is one K1 for one subwoofer, whether using K1-SB subwoofers only, SB28 subwoofers only, or a combination of both.

The [K1SB_60] and [SB28_60] presets provide the subwoofers with an upper frequency limit at 60 Hz for an optimal frequency coupling with the line source.

The K1-SB and SB28 subwoofer enclosures are driven by the LA8 amplified controller.

K1-SB

K1-SB provides an extension of the bandwidth in the low end, down to 30 Hz. Depending on the deployment, LF rejection can be produced.

Two deployments are available in this configuration:

- K1-SB beside the K1 or K1/K1-SB line source : side LF rejection (polarized)
- K1-SB behind the K1 or K1/K1-SB line source : rear LF rejection (cardioid)

Line source with K1-SB beside

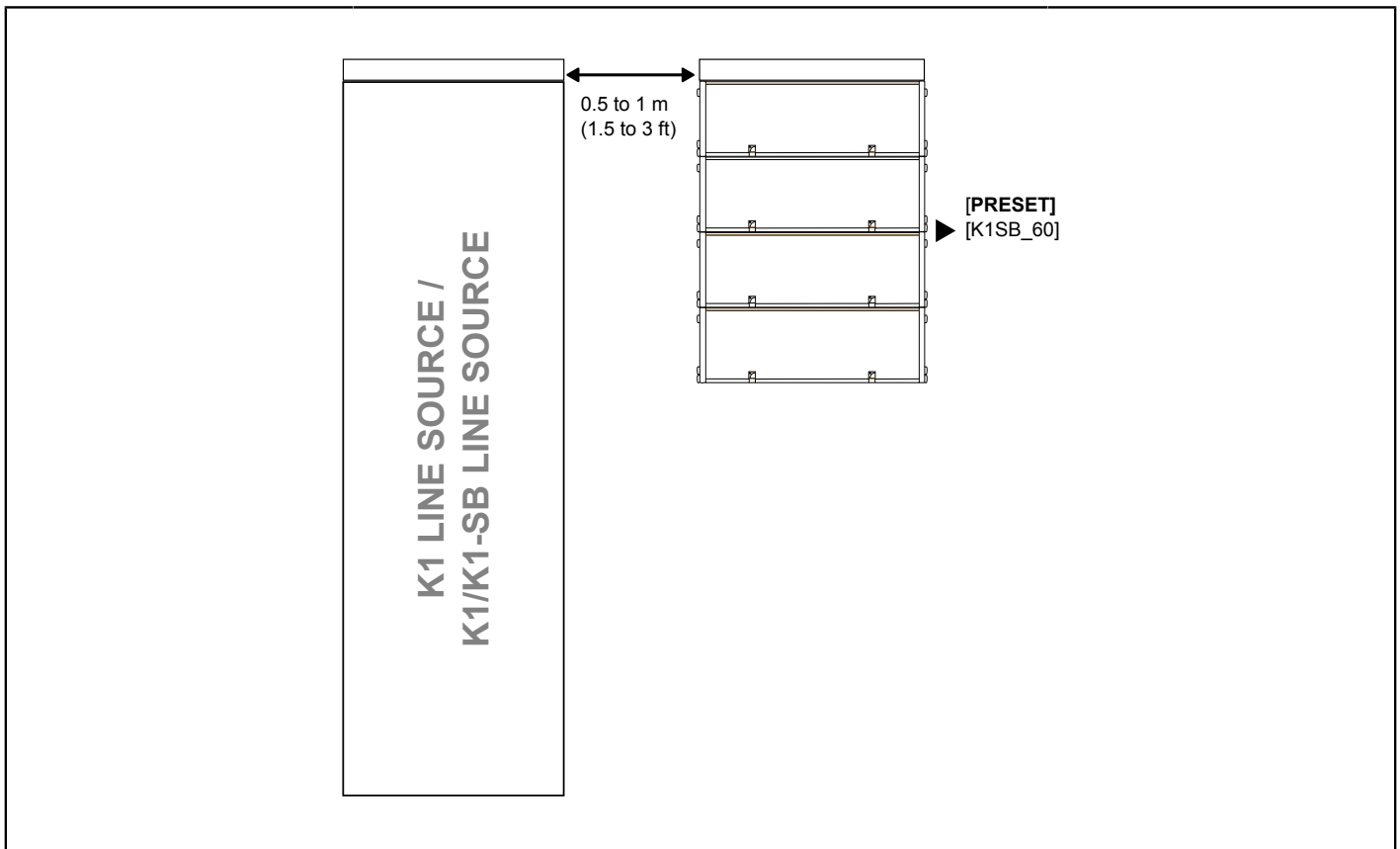

Enclosure	K1	K1-SB in line source	K1-SB as subwoofer
Preset	[K1]	[K1SB_X]	[K1SB_60]
Frequency range (-10 dB)	30 Hz - 20 kHz		
Recommended ratio	1 K1 : 1 subwoofer		
Recommended distance between front panels	Between 0.5 m (1.5 ft) and 1 m (3 ft)		



Delay values

Do not forget to add the pre-alignment and geometric delays depending on the configuration.



When using [K1] with [K1SB_X], do not add any delay value between the K1 and K1-SB elements of a same line source.

Pre-alignment delays

[K1] + [K1SB_60]	K1 = 6 ms	K1-SB = 0 ms
------------------	-----------	--------------

Line source with K1-SB behind

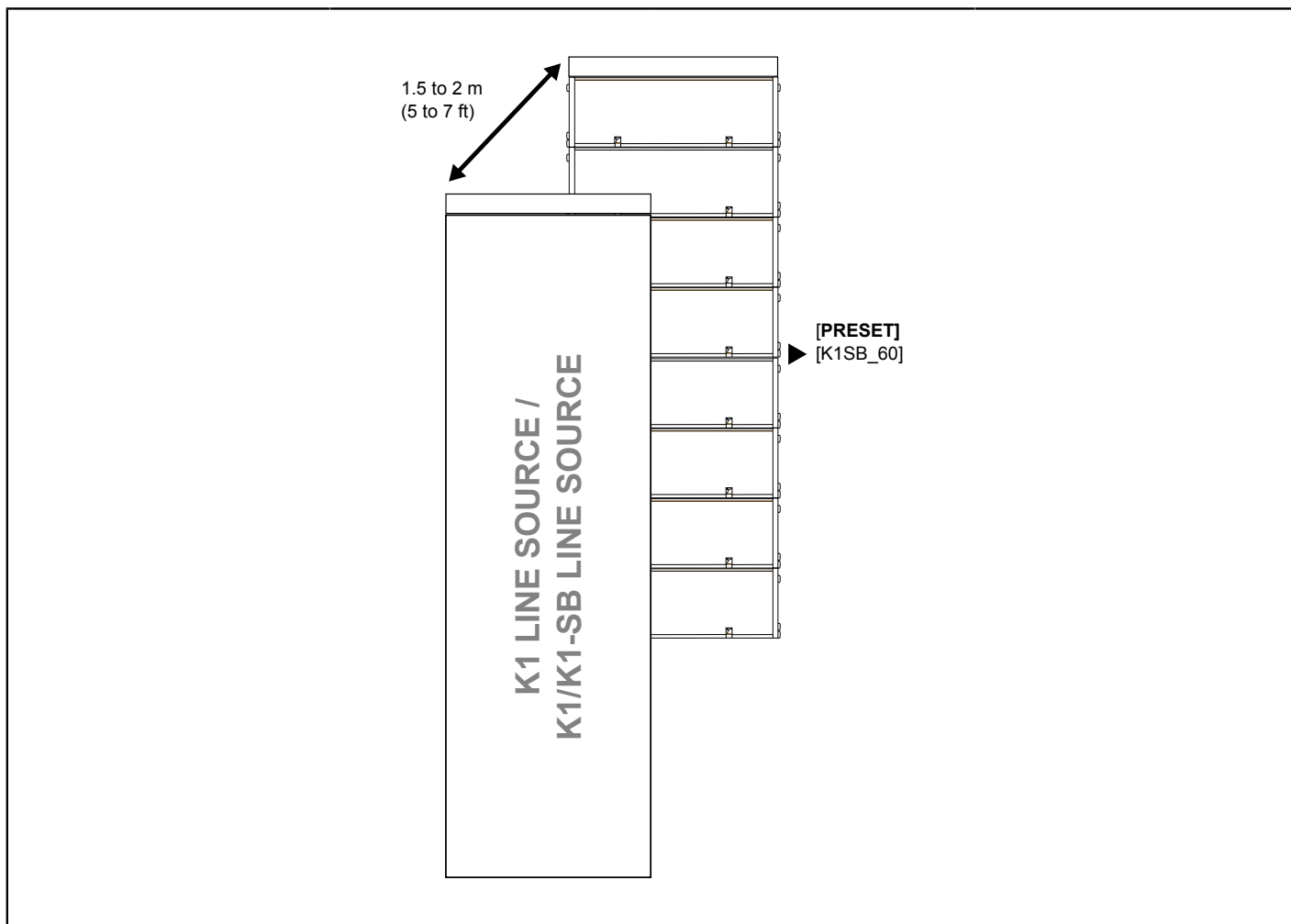

Enclosure	K1	K1-SB in line source	K1-SB as subwoofer
Preset	[K1]	[K1SB_X]	[K1SB_60]
Frequency range (-10 dB)	30 Hz - 20 kHz		
Recommended ratio	1 K1 : 1 subwoofer		
Recommended distance between front panels	Between 1.5 m (5 ft) and 2 m (7 ft)		

- ! Delay values**
Do not forget to add the pre-alignment and geometric delays depending on the configuration.
- ! When using [K1] with [K1SB_X], do not add any delay value between the K1 and K1-SB elements of a same line source.**

Pre-alignment delays

[K1] + [K1SB_60]	K1 = 6 ms	K1-SB = 0 ms
------------------	-----------	--------------

Geometric delays

1.5 m (5 ft)	Line source = 4.5 ms
2 m (7 ft)	Line source = 6 ms

SB28

The SB28 provides an extension of the bandwidth in the low end, down to 25 Hz.

Line source with SB28

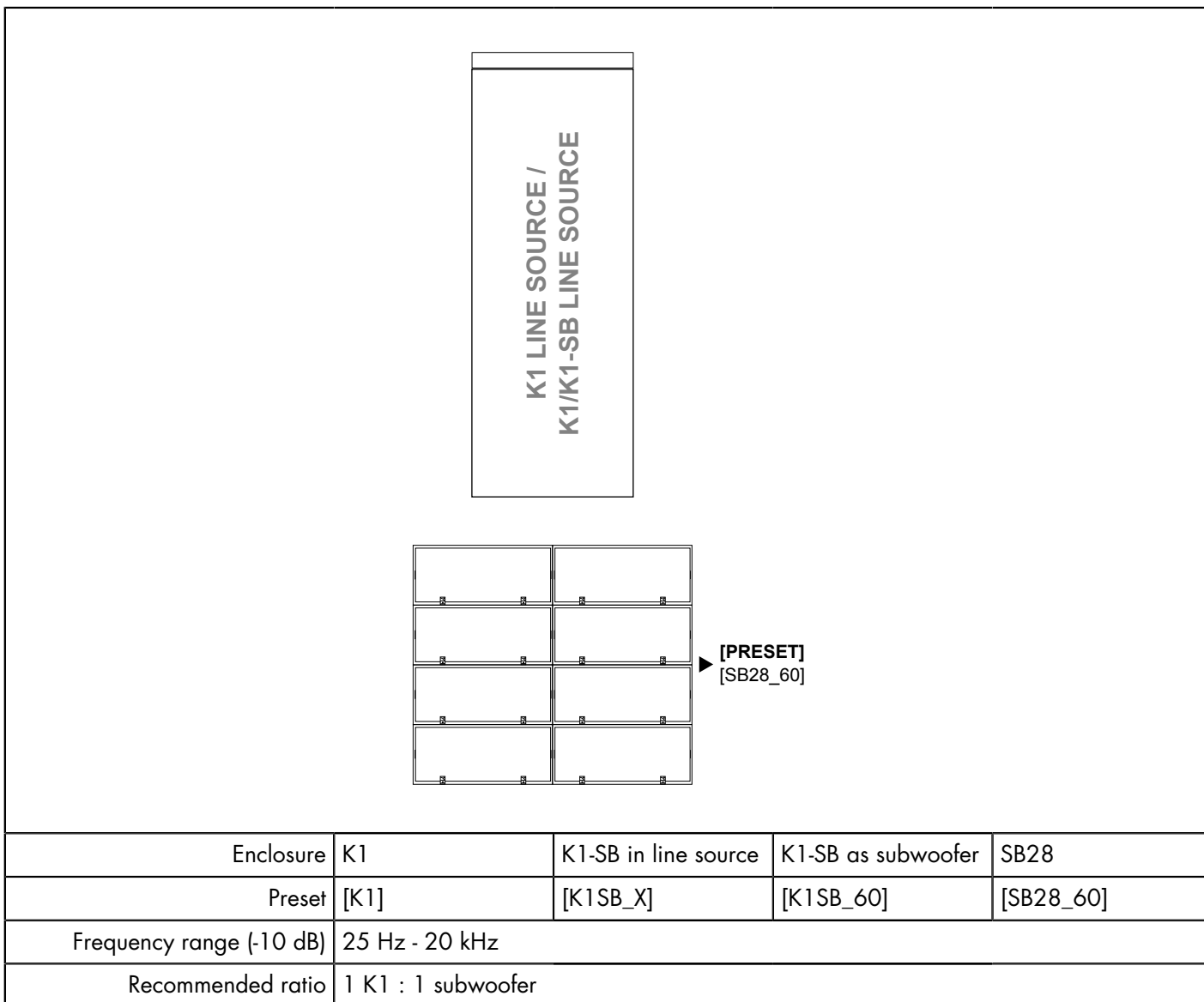

Grouping subwoofers

Place the subwoofer enclosures side by side. If not possible, the maximum distance between two adjacent acoustic centers must be 2.8 m or 1.7 m if the upper frequency limit of the subwoofer system is at 60 Hz or 100 Hz, respectively.



Use [xxxx_xx_C] on a reversed subwoofer in a cardioid configuration

The cardioid configuration consists in reversing 1 element in an array of 4 subwoofers.

Refer to the subwoofer user manual and to the **Cardioid configurations** technical bulletin.

Delay values

Do not forget to add the pre-alignment and geometric delays depending on the configuration.

 When using [K1] with [K1SB_X], do not add any delay value between the K1 and K1-SB elements of a same line source.

Pre-alignment delays

[K1] + [SB28_60]	K1 = 0 ms	SB28 = 6 ms	
[K1] + [SB28_60_C]	K1 = 0 ms	SB28 = 0.5 ms	
[K1] + [K1SB_60] + [SB28_60]	K1 = 8 ms	K1-SB = 2 ms	SB28 = 0 ms
[K1] + [K1SB_60] + [SB28_60_C]	K1 = 13.5 ms	K1-SB = 7.5 ms	SB28 = 0 ms

Additional downfill element

All K1 system configurations can be combined with an additional Kara or K2 line source downfill system. This allows an extension of the vertical coverage to the closer audience.

Kara

The [KARADOWNK1] preset features a high-pass filter at 100 Hz for the low section, along with specific delay settings, in order to optimize the acoustic coupling between the Kara and K1 line sources.

The Kara enclosure is driven by the LA8 amplified controller.

Line source with Kara downfill system

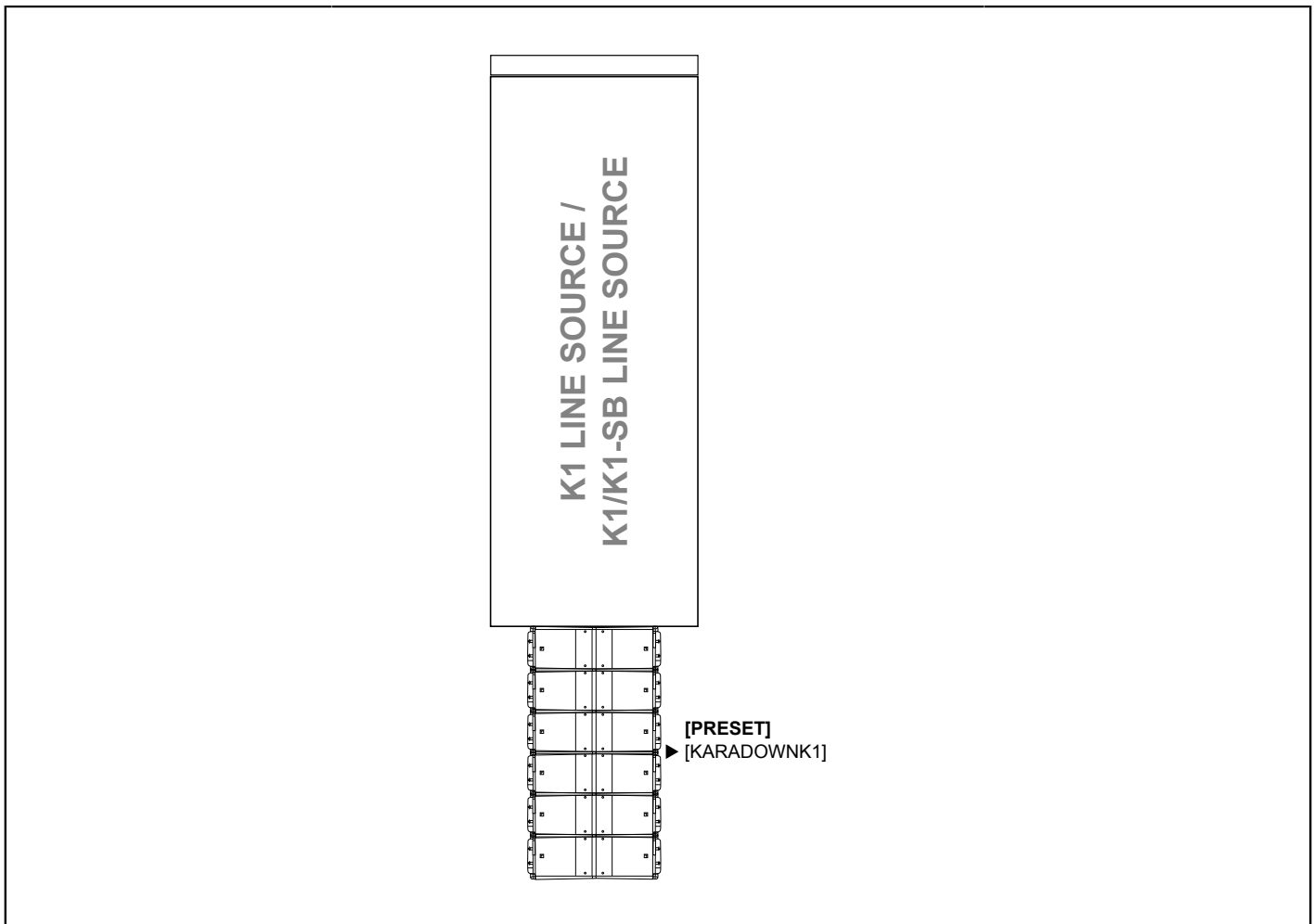

Enclosure	K1	K1-SB in line source	Kara
Preset	[K1]	[K1SB_X]	[KARADOWNK1]
Frequency range (-10 dB)	35 Hz - 20 kHz		
Kara array	Up to 6 Kara enclosures		



Do not add any delay between the K1 and Kara elements of a mixed line source.



When using [K1] with [K1SB_X], do not add any delay value between the K1 and K1-SB elements of a same line source.



Using the Kara system

Refer to the **Kara user manual** for the operating modes of Kara as a main system.

K2

The [K2 110] preset provides K2 with the same horizontal coverage as K1 for optimal downfill.

The K2 enclosure is driven by the LA8 amplified controller.

Line source with K2 downfill system

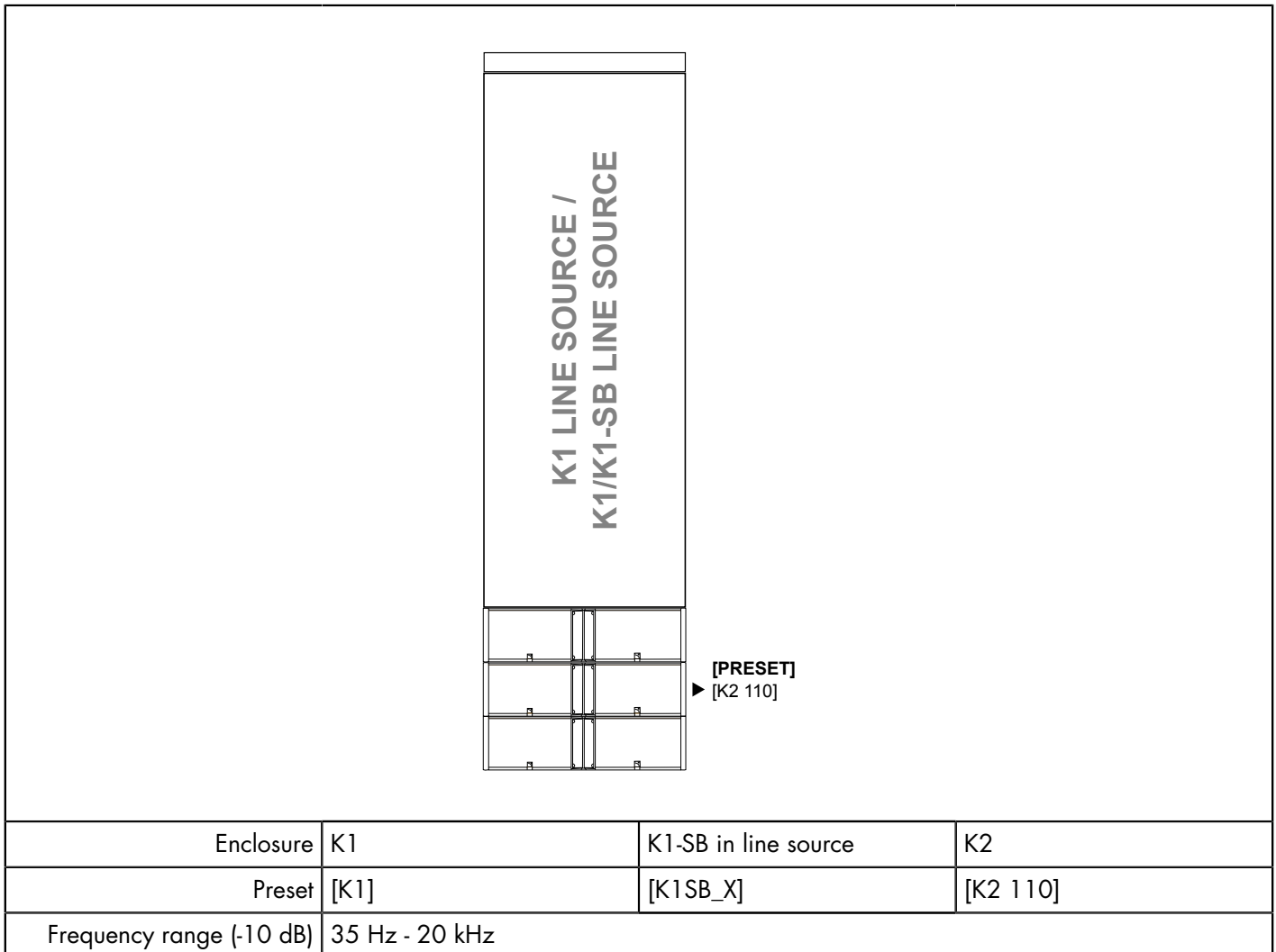

Do not add any delay between the K1 and K2 elements of a mixed line source.



When using [K1] with [K1SB_X], do not add any delay value between the K1 and K1-SB elements of a same line source.



Using the K2 system

Refer to the **K2 user manual** for the operating modes of K2 as a main system.

Loudspeaker connection

Connectors

The Kara is equipped with two 4-point speakON connectors.

Kara

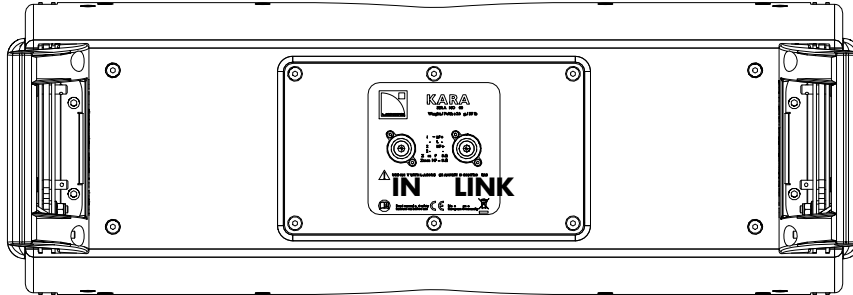

Internal pinout for L-Acoustics 2-way active enclosures

speakON points	1 +	1 -	2 +	2 -
Transducer connectors	LF +	LF -	HF +	HF -

The K1 is equipped with two 8-point PA-COM connectors.

K1

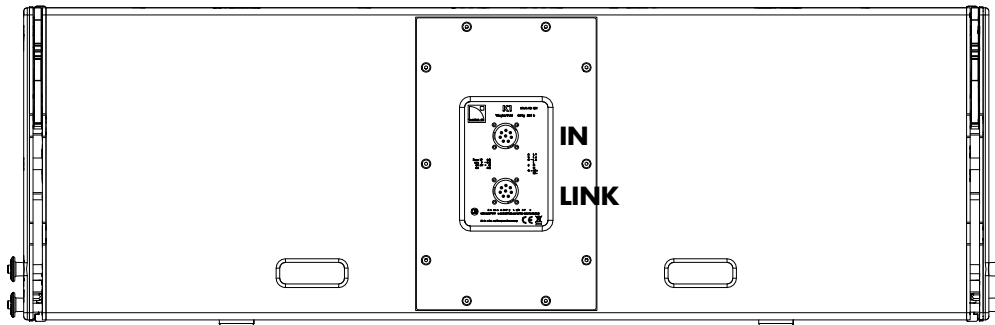

The K2 is equipped with two 8-point PA-COM connectors.

K2

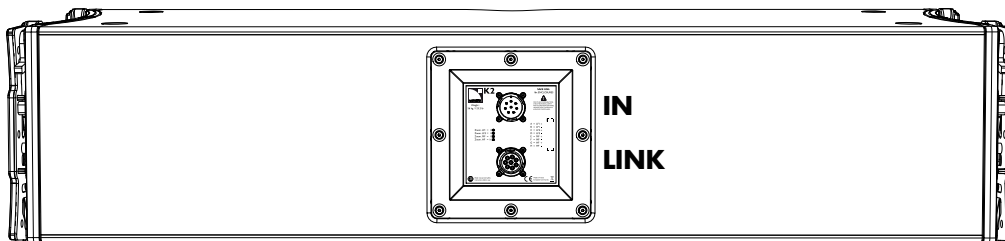

Internal pinout for L-Acoustics 3-way active enclosures

PA-COM points	A/B	C/D	E/F	G/H
Transducer connectors	left LF	right LF	MF	HF

The K1-SB is equipped with one 4-point speakON connector.

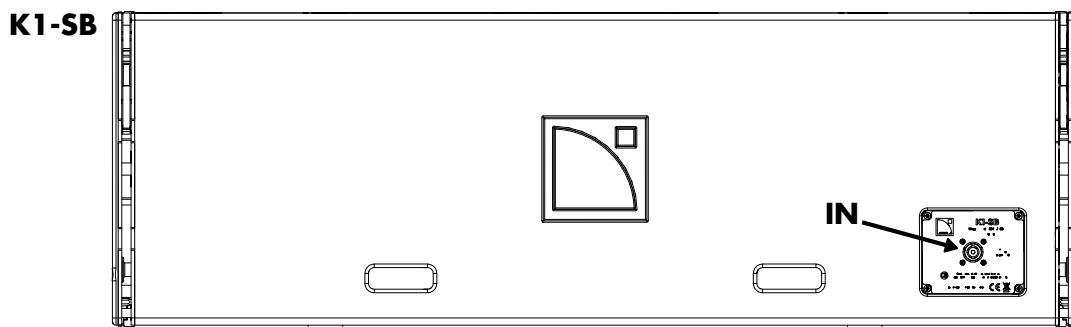

The SB28 is equipped with one 4-point speakON connector.

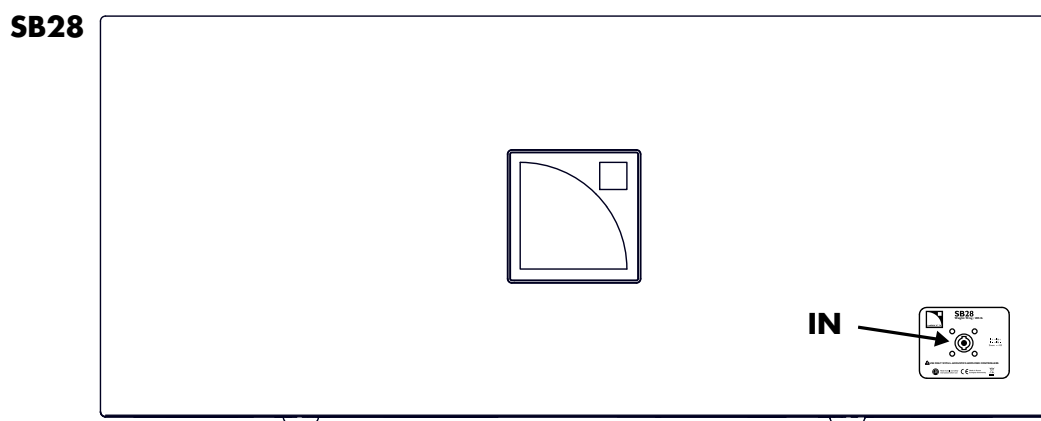

Internal pinout for L-Acoustics subwoofers

speakON points	1 +	1 -	2 +	2 -
Transducer connectors	LF +	LF -	Not linked	Not linked

Connection to LA8

Maximum number of enclosures per LA8

enclosure	max enclosures in parallel *	max enclosures per controller
K1	2	2
K2	3	3
Kara	3	6
K1-SB	1	4
SB28	1	4

* For passive loudspeakers, the value corresponds to the number of enclosures in parallel on the output. For active loudspeakers, the value corresponds to the number of sections in parallel on the output.

Impedance load

K1

- 1 enclosure: LF 8 Ω / MF 8 Ω / HF 8 Ω
- 2 enclosures in parallel: LF 4 Ω / MF 4 Ω / HF 4 Ω
- 3 enclosures in parallel: LF 2.7 Ω / MF 2.7 Ω / HF 2.7 Ω

K2

- 1 enclosure: LF 8 Ω / MF 8 Ω / HF 16 Ω
- 2 enclosures in parallel: LF 4 Ω / MF 4 Ω / HF 8 Ω
- 3 enclosures in parallel: LF 2.7 Ω / MF 2.7 Ω / HF 5.2 Ω

KARA

- 1 enclosure: LF 8 Ω / HF 8 Ω
- 2 enclosures in parallel: LF 4 Ω / HF 4 Ω
- 3 enclosures in parallel: LF 2.7 Ω / HF 2.7 Ω

SB28 K1-SB

- 1 enclosure: 4 Ω

Connecting 3-way active enclosures

DO on CA-COM output

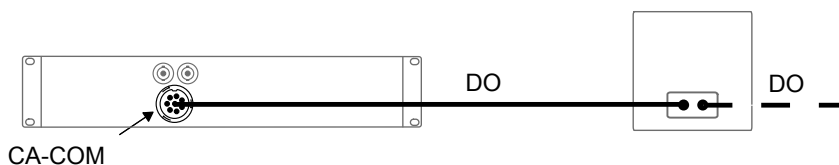

Connecting subwoofers

SP and SP-Y1 on speakON output

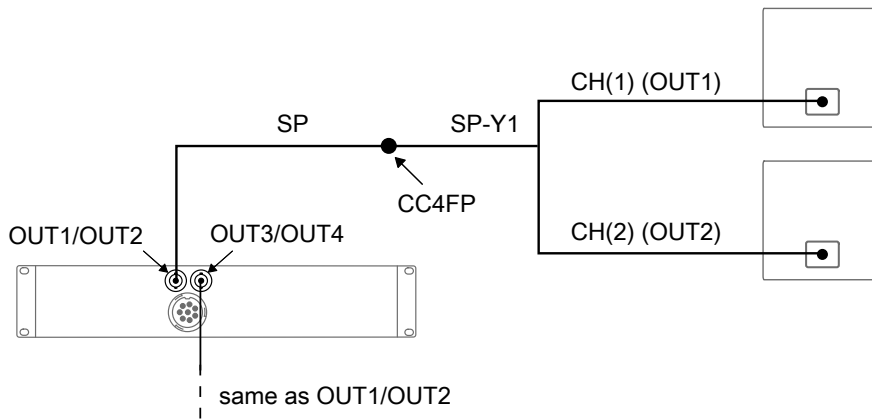

DO and DOSUB-LA8 on CA-COM output

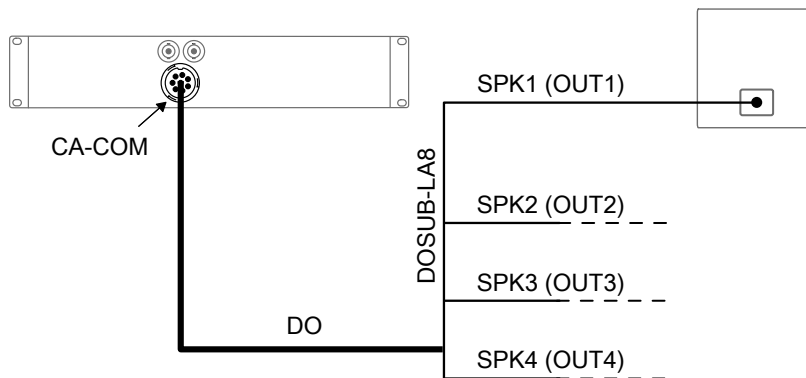

Connecting 2-way active enclosures

SP on speakON output

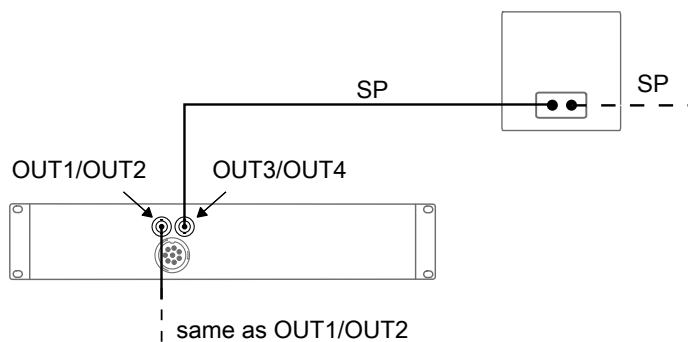

DO and DOFILL-LA8 on CA-COM output

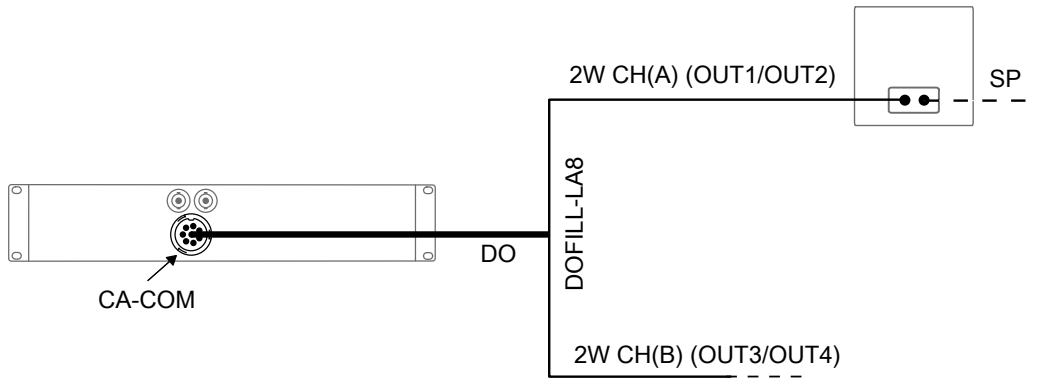

Connecting a 2-way active enclosure with subwoofers

DO and DO3WFILL on CA-COM output

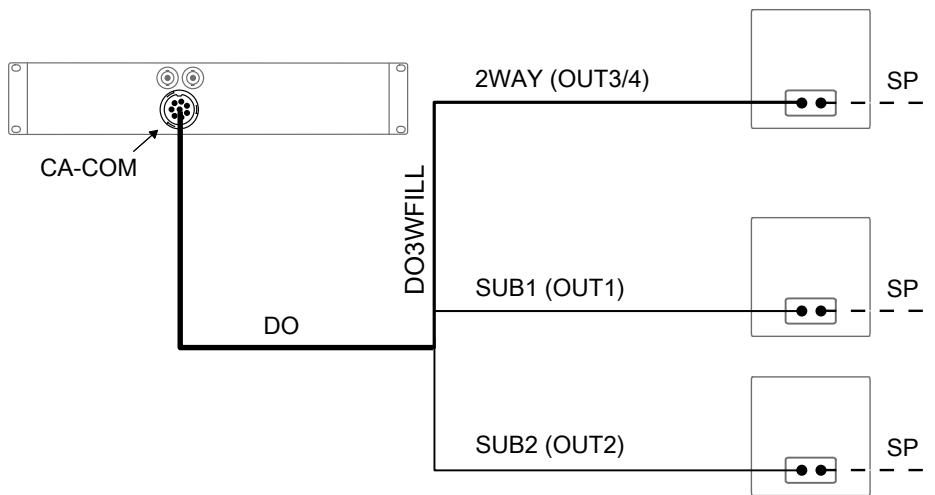

Preset description

[K1] [K2 110]

loudspeaker elements	outputs	channels	routing	gain	delay	polarity	mute
left LF	OUT 1	LF	IN A	0 dB	0 ms	+	ON
right LF	OUT 2	LF					ON
MF	OUT 3	MF					ON
HF	OUT 4	HF					ON

[KARA] [KARADOWNK1]

loudspeaker elements	outputs	channels	routing	gain	delay	polarity	mute
LF	OUT 1	LF	IN A	0 dB	0 ms	+	ON
HF	OUT 2	HF					ON
LF	OUT 3	LF	IN A	0 dB	0 ms	+	ON
HF	OUT 4	HF					ON

[K1SB_60] [K1SB_X] [SB28_60]

outputs	channels	routing	gain	delay	polarity	mute
OUT 1	SB	IN A	0 dB	0 ms	+	ON
OUT 2	SB	IN A	0 dB	0 ms	+	ON
OUT 3	SB	IN A	0 dB	0 ms	+	ON
OUT 4	SB	IN A	0 dB	0 ms	+	ON

[SB28_60_C]

loudspeaker elements	outputs	channels	routing	gain	delay	polarity	mute
SR	OUT 1	SR	IN A	0 dB	0 ms	+	ON
SB	OUT 2	SB					ON
SB	OUT 3	SB					ON
SB	OUT 4	SB					ON

Recommendation for speaker cables

Follow the recommended maximum length for loudspeaker cables to ensure minimal SPL attenuation.



Cable quality and resistance

Only use high-quality fully insulated speaker cables made of stranded copper wire.

Use cables with a gauge offering low resistance per unit length and keep the cables as short as possible.

The table below provides the recommended maximum length for loudspeaker cables depending on the cable gauge and on the impedance load connected to the amplifier.

cable gauge			recommended maximum length					
			8 Ω load		4 Ω load		2.7 Ω load	
mm ²	SWG	AWG	m	ft	m	ft	m	ft
2.5	15	13	30	100	15	50	10	33
4	13	11	50	160	25	80	17	53
6	11	9	74	240	37	120	25	80

For your installation projects, you can use the more detailed L-ACOUSTICS calculation tool to evaluate cable length and gauge based on the type and number of enclosures connected. The calculation tool is available on our website:

<http://www.l-acoustics.com/installation-outils-de-calcul-137.html>

Specifications

K1 specifications

Description	3-way full-range active WST enclosure, quad-amplified by LA8
Usable bandwidth (-10 dB)	35 Hz - 20 kHz ([K1])
Maximum SPL¹	149 dB ([K1])
Nominal directivity	horizontal: 90° symmetric vertical: dependent upon the number of elements and the line source curvature
Transducers	LF: 2 x 15" neodymium MF: 4 x 6.5" neodymium, direct radiation HF: 3 x 3" diaphragm compression drivers
Acoustical load	LF: bass-reflex MF: bass-reflex HF: DOSC waveguides
Nominal impedance	LF: 2 x 8 Ω MF: 8 Ω HF: 8 Ω
Connectors	IN: 1 x 8-point PA-COM LINK: 1 x 8-point PA-COM
Rigging and handling	handles integrated in the cabinet inter-enclosure angles: 0°, 0.5°, 1°, 1.5°, 2°, 2.5°, 3°, 4° or 5°
Weight (net)	106 kg / 234 lb
Cabinet	first grade Baltic birch plywood, high density polyethylene
Front	steel grill with anti-corrosion coating acoustically neutral 3D fabric
Rigging components	high grade steel with anti-corrosion coating
Finish	grey brown RAL 8019

¹ Peak level measured at 1 m under free field conditions using pink noise with crest factor 4 (preset specified in brackets).

K1 dimensions

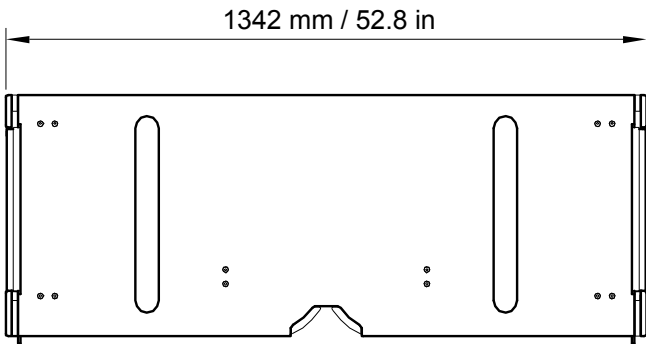
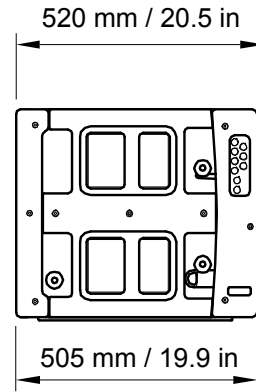
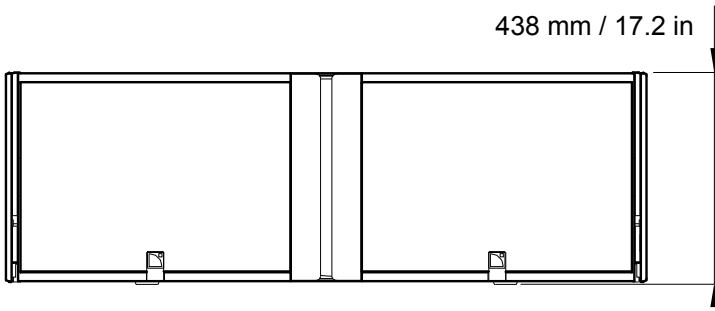
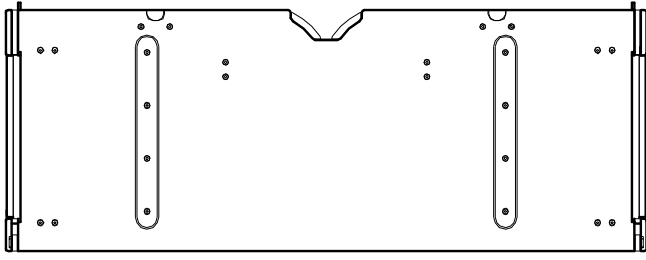

K2 specifications

Description	3-way full-range active WST enclosure, quad-amplified by LA4X / LA8
Usable bandwidth (-10 dB)	35 Hz - 20 kHz ([K2 70])
Maximum SPL¹	147 dB ([K2 70])
Nominal directivity	horizontal: 110° / 70° symmetric or 90° asymmetric (35°/55° or 55°/35°) vertical: dependent upon the number of elements and the line source curvature
Transducers	LF: 2 x 12" MF: 4 x 6.5" HF: 2 x 3" diaphragm compression driver
Acoustical load	LF: bass-reflex, L-Vents MF: bass-reflex HF: DOSC waveguides
Nominal impedance	LF: 2 x 8 Ω MF: 8 Ω HF: 16 Ω
Connectors	IN: 1 x 8-point PA-COM LINK: 1 x 8-point PA-COM
Rigging and handling	captive 4-point rigging system inter-enclosure angles: 0.25°, 1°, 2°, 3°, 4°, 5°, 7.5° or 10°
Weight (net)	56 kg / 123.2 lb
Cabinet	first grade Baltic birch plywood
Front	steel grill with anti-corrosion coating acoustically neutral 3D fabric
Rigging components	high grade steel with anti-corrosion coating
Finish	dark grey brown Pantone 426C
IP	IP45

¹ Peak level measured at 1 m under free field conditions using pink noise with crest factor 4 (preset specified in brackets).

K2 dimensions

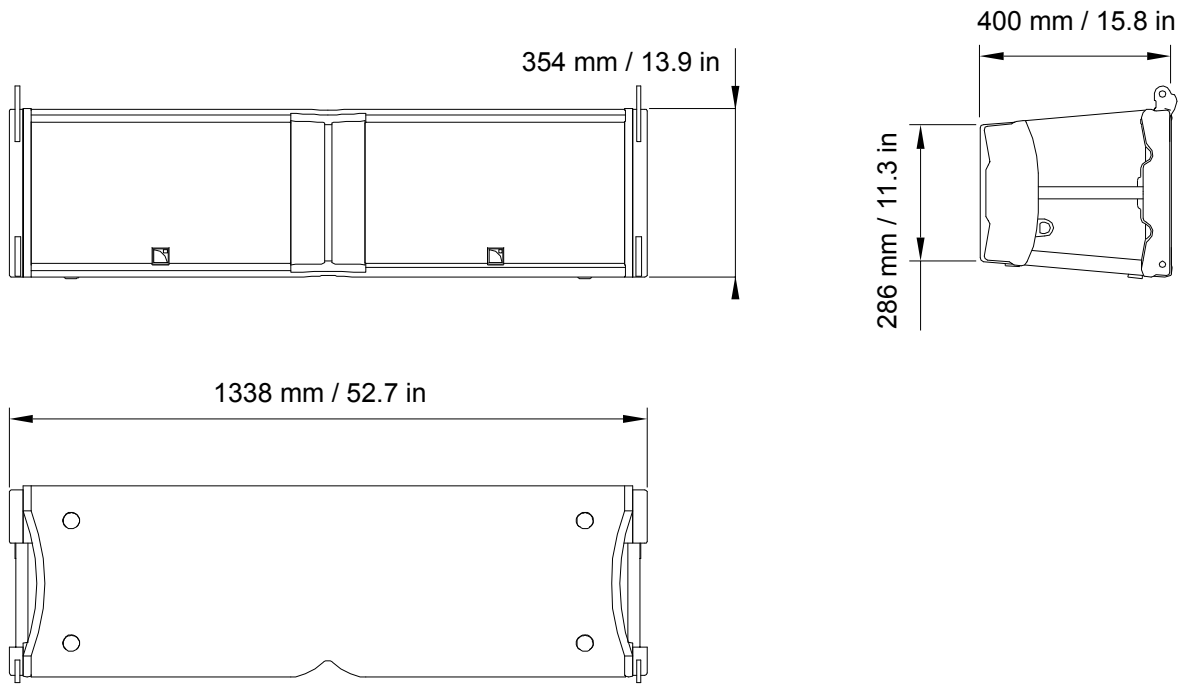

Kara specifications

Description	2-way modular WST enclosure, quad-amplified by LA4X / LA8
Usable bandwidth (-10 dB)	55 Hz - 20 kHz ([KARA])
Maximum SPL¹	141 dB ([KARA])
Nominal directivity	horizontal: 110° symmetric vertical: dependent upon the number of elements and the line source curvature
Transducers	LF: 2 x 8" neodymium HF: 1 x 3", neodymium, diaphragm compression driver
Acoustical load	LF: bass-reflex HF: DOSC waveguide
Nominal impedance	LF: 8 Ω HF: 8 Ω
Connectors	IN: 1 x 4-point speakON LINK: 1 x 4-point speakON
Rigging and handling	captive rigging system handles integrated into the cabinet inter-enclosure angles: 0°, 1°, 2°, 3°, 4°, 5°, 7.5° or 10°
Weight (net)	26 kg / 57 lb
Cabinet	first grade Baltic birch plywood
Front	steel grill with anti-corrosion coating acoustically neutral 3D fabric
Rigging components	high grade steel with anti-corrosion coating
Finish	dark grey brown Pantone 426C
IP	IP45

¹ Peak level measured at 1 m under free field conditions using pink noise with crest factor 4 (preset specified in brackets).

Kara dimensions

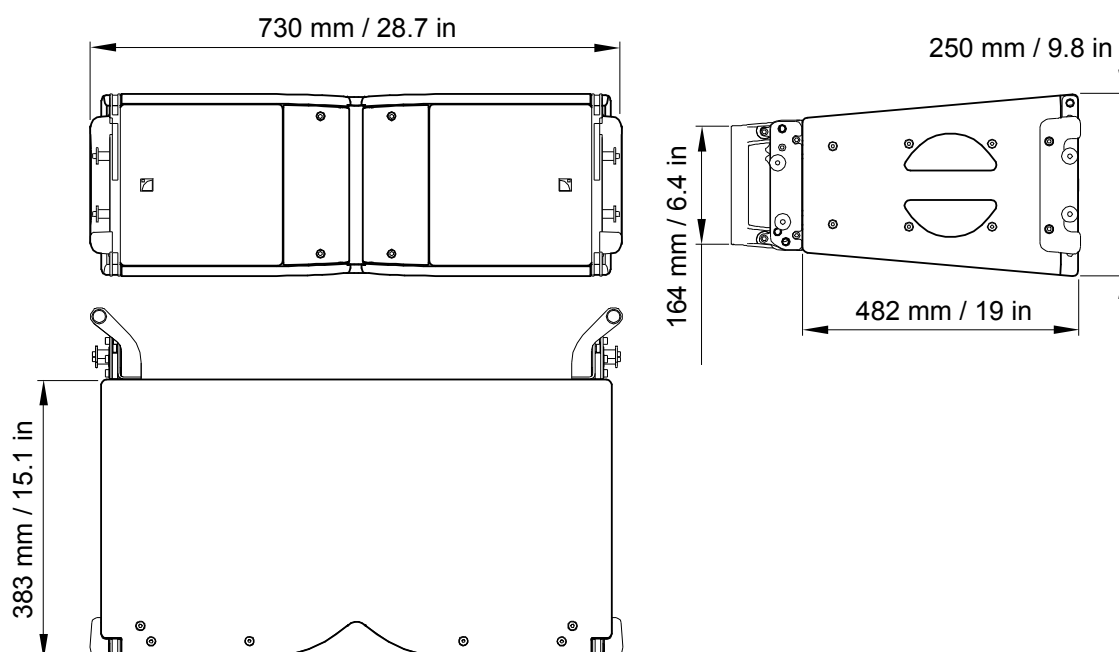

K1-SB specifications

Description	K1-SB system subwoofer 2 x 15", amplified by LA8
Low frequency limit (-10 dB)	30 Hz ([K1SB_60])
Maximum SPL¹	145 dB ([K1SB_X])
Transducers	2 x 15", 4" coil, magnesium die-cast basket, vented magnet design
Acoustical load	bass-reflex, L-Vents
Nominal impedance	4 Ω
Connectors	IN: 1 x 4-point speakON
Rigging and handling	captive 4-point rigging system inter-enclosure angles: 0°, 0.5°, 1°, 1.5°, 2°, 2.5°, 3°, 4° or 5° handles integrated into the cabinet
Weight (net)	83 kg / 183 lb
Cabinet	first grade Baltic birch plywood
Front	steel grill with anti-corrosion coating acoustically neutral 3D fabric
Rigging components	high grade steel with anti-corrosion coating
Finish	dark grey brown Pantone 426C
IP	IP55

¹ Peak level at 1 m under half space conditions using pink noise with crest factor 4 (preset specified in brackets).

K1-SB dimensions

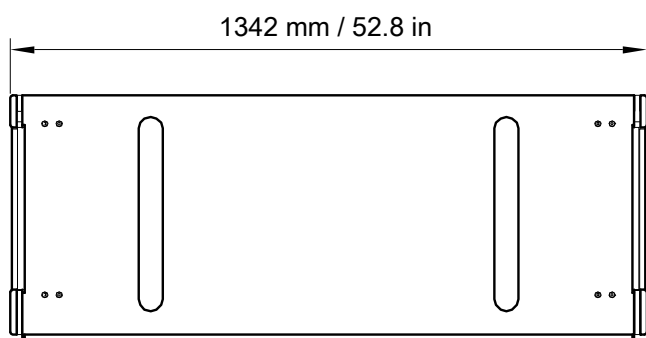
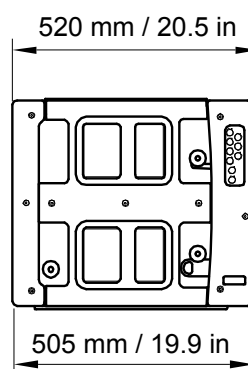
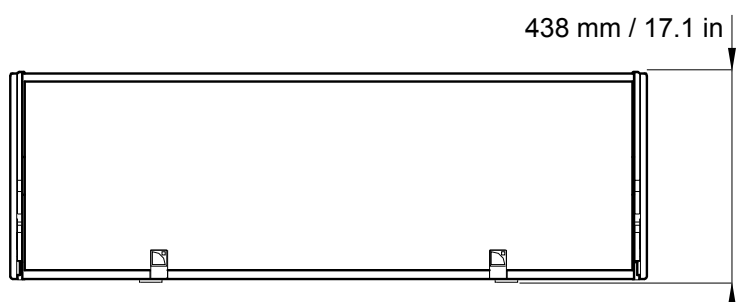
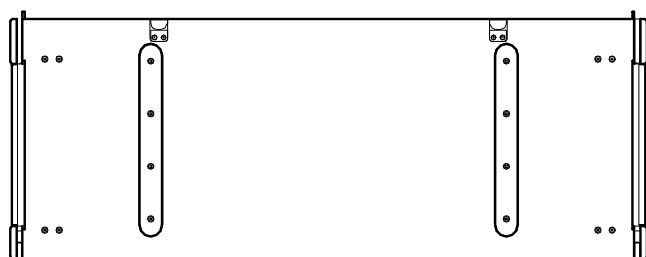

SB28 specifications

Description	high power subwoofer 2×18", amplified by LA8
Low frequency limit (-10 dB)	25 Hz ([SB28_100])
Maximum SPL¹	142 dB ([SB28_100])
Directivity	standard or cardioid
Transducers	2 × 18" neodymium, direct radiation
Acoustical load	bass-reflex, L-Vents
Nominal impedance	4 Ω
Connectors	IN: 1 × 4-point speakON
Rigging and handling	integrated rigging system handles integrated in the cabinet
Weight (net)	93 kg / 205 lb
Cabinet	first grade Baltic birch plywood
Front	steel grill with anti-corrosion coating acoustically neutral 3D fabric
Rigging components	high grade steel with anti-corrosion coating
Finish	dark grey brown Pantone 426C

¹ Peak level at 1 m under half space conditions using pink noise with crest factor 4 (preset specified in brackets).

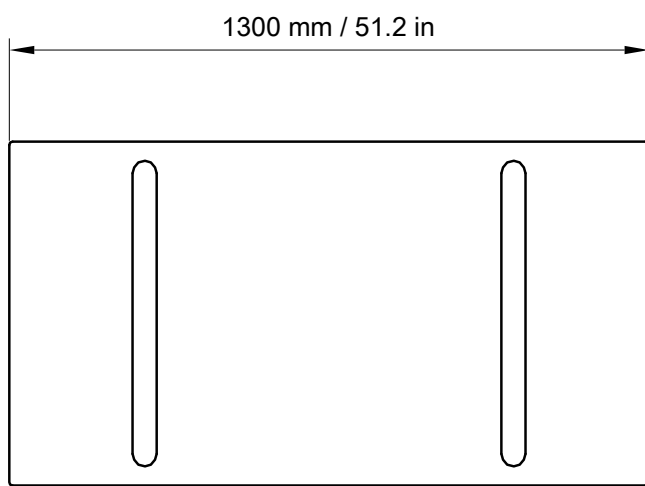
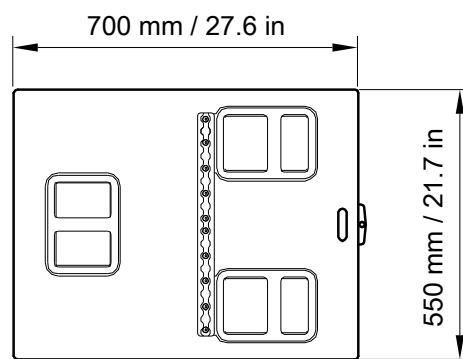
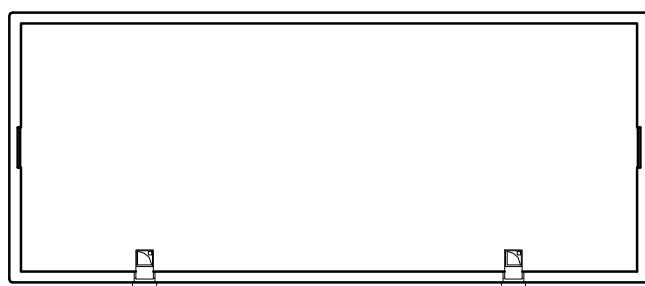
SB28 dimensions



L-Acoustics, an L-Group Company

13 rue Levacher Cintrat - 91460 Marcoussis - France

+33 1 69 63 69 63 - info@l-acoustics.com

www.l-acoustics.com

L-Acoustics GmbH

Steiermärker Str. 3-5
70469 Stuttgart
Germany
+49 7 11 89660 323

L-Acoustics Ltd.

PO. Box Adler Shine - Aston House
Cornwall Avenue - London N3 1LF
United Kingdom
+44 7224 11 234

L-Acoustics Inc.

2645 Townsgate Road, Suite 600
Westlake Village, CA 91361
USA
+1 805 604 0577



L-GROUP

www.l-group.com