

# PZM-180 Hand Held Mic

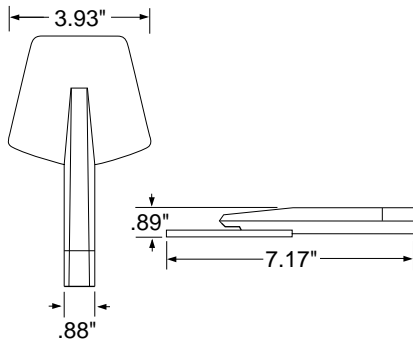

Fig. 1 PZM-180 Hand Held Mic

## PZM-180

The PZM<sup>®</sup>-180 is a Pressure Zone Microphone<sup>®</sup> designed for general-purpose applications such as conferences, group discussions, interviews, broadcast news and sports, home video production, lectures, and music recordings. The microphone can be placed on a large surface such as a table, floor, wall, or lectern; or can be hand-held for interviews. The PZM-180 is relatively insensitive to mechanical vibrations such as table thumps or handling noise. Its electret-condenser capsule provides a wide, smooth frequency response from 50 Hz to 18 kHz and its hemispherical polar pattern allows clear pickup of everyone surrounding the microphone.

The PZM-180 can be phantom-powered or battery-powered. Connecting the microphone to a phantom-power supply disconnects the internal battery. The output is balanced, low impedance, which allows long cable runs without hum pickup or high-frequency loss.

Like other PZMs, the 180 utilizes the Pressure Recording Process<sup>™</sup> in which a miniature condenser microphone capsule is arranged very close to a sound-reflecting plate or boundary. The capsule is mounted in the "Pressure Zone" just above the boundary, a region where sound coming directly from the sound source combines in phase with sound reflected off the boundary. The benefits are a wide, smooth frequency response free of phase interference, excellent clarity and "reach," a hemispherical polar pattern and uncolored off-axis response.

## Operation

If battery power is desired, insert a 1.5 volt size N battery into the battery holder; refer to Figs. 5 and 6. The battery should provide at least 6 months of continuous operation. To increase the sensitivity of the PZM-180 by 4 to 10 dB: Remove the 1.5-volt N-cell and substitute a 6-volt Duracell PX28 battery (available

at any camera store). Push the battery clips together to hold the smaller 6-volt battery. A 1.5 V size N battery and a windscreen are included.

If you desire phantom power, plug a mic cable between the PZM-180 and the input of a phantom-power supply. Connect another mic cable between the phantom-supply output and a mic input on your mixer or recorder.

## Warranty

Crown professional microphones are guaranteed unconditionally against malfunction from any cause for a period of three years from date of original purchase. If such malfunction occurs, microphone will be repaired or replaced (at our option) without charge for materials or labor. If the microphone seems to be defective, return the microphone in its original packaging to Crown's Service Department at 57620 CR 105, Elkhart, IN 46517. For further assistance or technical support call 800-342-6939.

## Specifications

**Type:** Pressure Zone Microphone.

**Transducer:** Electret condenser.

**Frequency response (typical):** 50 Hz to 18 kHz. See Figs. 2 and 3.

**Polar pattern:** Hemispherical when mounted on a surface boundary. On a stand the mic is omnidirectional at lower frequencies and unidirectional at higher frequencies. See Fig. 4.

**Impedance:** 150 ohms, balanced. Recommended minimum load impedance 1000 ohms.

**Open-circuit sensitivity:** Battery: 0.8 mV/Pa\* (-62 dB re 1 V/Pa\*). Phantom: 3.2 mV/Pa\* (-50 dB re 1 V/Pa\*).

**Power sensitivity:** Battery: -59.5 dBm. Phantom: -47.5 dBm.

**Equivalent noise level:** 21 dB SPL typical (0 dB = .0002 dyne/cm<sup>2</sup>), A-weighted.

**Maximum SPL at 3% THD:** 120 dB SPL.

**Operating voltage:** 12 to 48 VDC phantom power (positive voltage on pins 2 and 3 with respect to pin 1 of output connector), or 1.5V size N battery (Ray-O-Vac 810 or equivalent) or 6V battery (Duracell PX28 or equivalent).

**Output Connector:** Standard male XLR.

**Cable:** None supplied.

**Materials:** Carbon filled nylon, black finish.

**Weight:** 2.4 oz (68 g).

**Dimensions:** See Fig. 1.

\*1 pascal = 10 microbars = 10 dynes/cm<sup>2</sup> = 94 dB SPL.

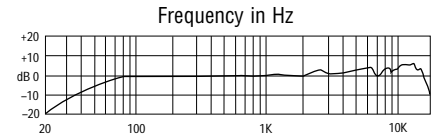

Fig. 2 Frequency Response on a Boundary

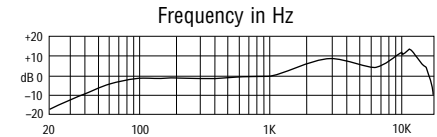

Fig. 3 Frequency Response on a Mic Stand

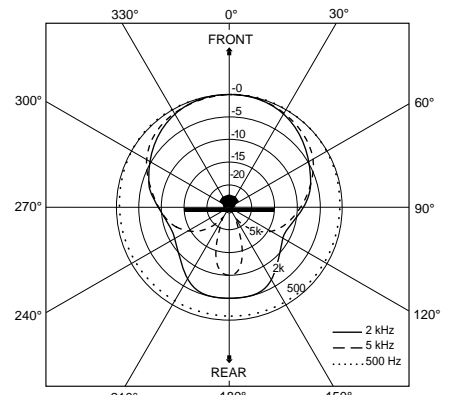

Fig. 4 Free Field Polar Response

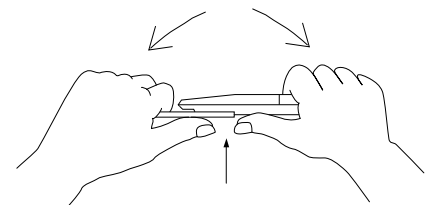
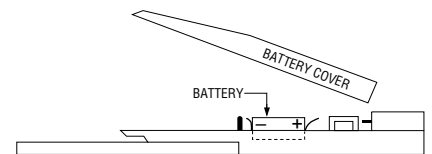

Fig. 5 Battery Cover Removal



BATTERY INSTALLATION  
Fig. 6 Battery Replacement



**Guaranteed Excellence**

Crown International, Inc.  
PO Box 1000 Elkhart, IN 46515-1000  
Ph. 800-342-6939/219-294-8200  
Fax. 219-294-8301  
Auto-Fax: 800-294-4094/219-293-9200  
<http://www.crownintl.com>

## Trademark Notice:

Crown<sup>®</sup>, Pressure Zone Microphone<sup>®</sup>, and PZM<sup>®</sup> are registered trademarks of Crown International Inc.